

© by Stamicarbon B.V.

Reliable

Reliable, redundant measurement

Cost effective

One detector type for all measuring tasks

User friendly

Maintenance-free operation

Urea reboiler

Level measurement and point level detection in the reboiler during the distillation of urea

In the production of urea from ammonia, high process temperatures and the urea itself limit any sensor material selection considerably. The thick container walls further complicate the installation of measurement technology. A reliable monitoring of the level is essential to enable the cost-effective production of urea.

[More details](#)

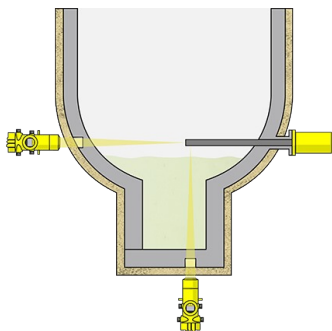

MINITRAC 31

Continuous level measurement with radiometry under difficult process conditions

- Maintenance-free measuring system for exact, reliable level information
- Compact design allows installation even in difficult-to-access, cramped spaces
- The radioactive source can be inserted into a double-walled, closed immersion tube in the wall of the urea reactor

[Show Product](#)

MINITRAC 31
[Show Product](#)**Measuring range - Distance**

-

Process temperature

-40 ... 60 °C

Process pressure

-

Accuracy

0.1 %

Materials, wetted parts

No wetted material

Seal material

no media contact

Housing materialAluminium
Stainless steel (precision casting)**Protection rating**

IP66/IP67

OutputProfibus PA
Foundation Fieldbus
Four-wire: 4 ... 20 mA/HART**Ambient temperature**

-40 ... 60 °C