

Operating Instructions

Submersible pressure transmitter with
metal measuring cell

VEGABAR 87

Modbus and Levelmaster protocol



Document ID: 46297



VEGA

Contents

1	About this document	4
1.1	Function	4
1.2	Target group	4
1.3	Symbols used	4
2	For your safety	5
2.1	Authorised personnel	5
2.2	Appropriate use	5
2.3	Warning about incorrect use	5
2.4	General safety instructions	5
2.5	Conformity	5
2.6	NAMUR recommendations	6
2.7	Installation and operation in the USA and Canada	6
2.8	Environmental instructions	6
3	Product description	7
3.1	Configuration	7
3.2	Principle of operation	8
3.3	Packaging, transport and storage	10
3.4	Accessories	10
4	Mounting	12
4.1	General instructions	12
4.2	Ventilation and pressure compensation	14
4.3	Level measurement	15
4.4	External housing	15
5	Connecting to power supply and bus system	16
5.1	Preparing the connection	16
5.2	Connecting	17
5.3	Wiring plan	19
5.4	External housing	20
5.5	Switch-on phase	22
6	Set up the sensor with the display and adjustment module	23
6.1	Insert display and adjustment module	23
6.2	Adjustment system	24
6.3	Measured value indication	25
6.4	Parameter adjustment - Quick setup	26
6.5	Parameter adjustment - Extended adjustment	26
6.6	Menu overview	36
6.7	Save parameter adjustment data	37
7	Setting up sensor and Modbus interface with PACTware	38
7.1	Connect the PC	38
7.2	Parameterization	39
7.3	Set instrument address	40
7.4	Save parameter adjustment data	41
8	Diagnosis, asset management and service	42
8.1	Maintenance	42
8.2	Diagnosis memory	42
8.3	Asset Management function	43
8.4	Rectify faults	45

8.5	Exchange process module on version IP68 (25 bar)	46
8.6	Exchanging the electronics module.....	47
8.7	Software update	47
8.8	How to proceed if a repair is necessary.....	48
9	Dismount.....	49
9.1	Dismounting steps.....	49
9.2	Disposal	49
10	Supplement	50
10.1	Technical data	50
10.2	Device communication Modbus	58
10.3	Modbus register	59
10.4	Modbus RTU commands	61
10.5	Levelmaster commands	64
10.6	Configuration of typical Modbus hosts	67
10.7	Calculation of the total deviation.....	67
10.8	Practical example.....	68
10.9	Dimensions	70
10.10	Industrial property rights.....	78
10.11	Trademark	78



Safety instructions for Ex areas:

Take note of the Ex specific safety instructions for Ex applications. These instructions are attached as documents to each instrument with Ex approval and are part of the operating instructions.

Editing status: 2023-09-01

1 About this document

1.1 Function

This instruction provides all the information you need for mounting, connection and setup as well as important instructions for maintenance, fault rectification, safety and the exchange of parts. Please read this information before putting the instrument into operation and keep this manual accessible in the immediate vicinity of the device.

1.2 Target group

This operating instructions manual is directed to trained personnel. The contents of this manual must be made available to the qualified personnel and implemented.

1.3 Symbols used



Document ID

This symbol on the front page of this instruction refers to the Document ID. By entering the Document ID on www.vega.com you will reach the document download.



Information, note, tip: This symbol indicates helpful additional information and tips for successful work.



Note: This symbol indicates notes to prevent failures, malfunctions, damage to devices or plants.



Caution: Non-observance of the information marked with this symbol may result in personal injury.



Warning: Non-observance of the information marked with this symbol may result in serious or fatal personal injury.



Danger: Non-observance of the information marked with this symbol results in serious or fatal personal injury.



Ex applications

This symbol indicates special instructions for Ex applications.



List

The dot set in front indicates a list with no implied sequence.



Sequence of actions

Numbers set in front indicate successive steps in a procedure.



Disposal

This symbol indicates special instructions for disposal.

2 For your safety

2.1 Authorised personnel

All operations described in this documentation must be carried out only by trained and authorized personnel.

During work on and with the device, the required personal protective equipment must always be worn.

2.2 Appropriate use

Model VEGABAR 87 is a pressure transmitter for level and gauge measurement.

You can find detailed information about the area of application in chapter " *Product description*".

Operational reliability is ensured only if the instrument is properly used according to the specifications in the operating instructions manual as well as possible supplementary instructions.

2.3 Warning about incorrect use

Inappropriate or incorrect use of this product can give rise to application-specific hazards, e.g. vessel overfill through incorrect mounting or adjustment. Damage to property and persons or environmental contamination can result. Also, the protective characteristics of the instrument can be impaired.

2.4 General safety instructions

This is a state-of-the-art instrument complying with all prevailing regulations and directives. The instrument must only be operated in a technically flawless and reliable condition. The operating company is responsible for the trouble-free operation of the instrument. When measuring aggressive or corrosive media that can cause a dangerous situation if the instrument malfunctions, the operating company has to implement suitable measures to make sure the instrument is functioning properly.

The safety instructions in this operating instructions manual, the national installation standards as well as the valid safety regulations and accident prevention rules must be observed.

For safety and warranty reasons, any invasive work on the device beyond that described in the operating instructions manual may be carried out only by personnel authorised by us. Arbitrary conversions or modifications are explicitly forbidden. For safety reasons, only the accessory specified by us must be used.

To avoid any danger, the safety approval markings and safety tips on the device must also be observed.

2.5 Conformity

The device complies with the legal requirements of the applicable country-specific directives or technical regulations. We confirm conformity with the corresponding labelling.

The corresponding conformity declarations can be found on our homepage.

2.6 NAMUR recommendations

NAMUR is the automation technology user association in the process industry in Germany. The published NAMUR recommendations are accepted as the standard in field instrumentation.

The device fulfils the requirements of the following NAMUR recommendations:

- NE 21 – Electromagnetic compatibility of equipment
- NE 53 – Compatibility of field devices and display/adjustment components
- NE 107 – Self-monitoring and diagnosis of field devices

For further information see www.namur.de.

2.7 Installation and operation in the USA and Canada

This information is only valid for USA and Canada. Hence the following text is only available in the English language.

Installations in the US shall comply with the relevant requirements of the National Electrical Code (NEC - NFPA 70) (USA).

Installations in Canada shall comply with the relevant requirements of the Canadian Electrical Code (CEC Part) (Canada).

2.8 Environmental instructions

Protection of the environment is one of our most important duties. That is why we have introduced an environment management system with the goal of continuously improving company environmental protection. The environment management system is certified according to DIN EN ISO 14001.

Please help us fulfil this obligation by observing the environmental instructions in this manual:

- Chapter "*Packaging, transport and storage*"
- Chapter "*Disposal*"

3 Product description

3.1 Configuration

Scope of delivery

The scope of delivery encompasses:

- VEGABAR 87 pressure transmitter

The further scope of delivery encompasses:

- Documentation
 - Quick setup guide VEGABAR 87
 - Test certificate for pressure transmitters
 - Instructions for optional instrument features
 - Ex-specific "*Safety instructions*" (with Ex versions)
 - If necessary, further certificates



Information:

Optional instrument features are also described in this operating instructions manual. The respective scope of delivery results from the order specification.

Type label

The type label contains the most important data for identification and use of the instrument:

- Instrument type
- Information about approvals
- Configuration information
- Technical data
- Serial number of the instrument
- QR code for device identification
- Numerical code for Bluetooth access (optional)
- Manufacturer information

Documents and software

To find order data, documents or software related to your device, you have the following options:

- Move to "www.vega.com" and enter in the search field the serial number of your instrument.
- Scan the QR code on the type label.
- Open the VEGA Tools app and enter the serial number under "**Documentation**".

Electronics design

The instrument contains two different electronics in its housing chambers:

- The Modbus electronics for power supply and communication with the Modbus-RTU
- The sensor electronics for the actual measuring tasks

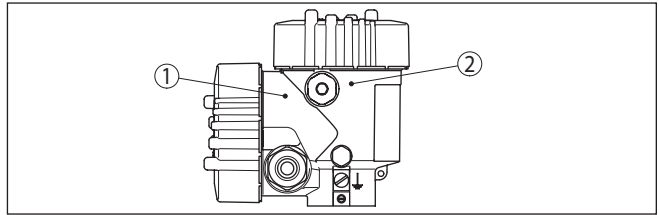

Fig. 1: Position of Modbus and sensor electronics

- 1 Modbus electronics
- 2 Sensor electronics

3.2 Principle of operation

Application area

The VEGABAR 87 is a pressure transmitter for pressure and level measurements of liquids with higher temperatures in the chemical, food processing and pharmaceutical industry.

Measured products

Measured products are liquids.

Depending on the instrument version and the measurement setup, the measured products can be also viscous.

Measured variables

The VEGABAR 87 is suitable for the measurement of the following process variables:

- Level

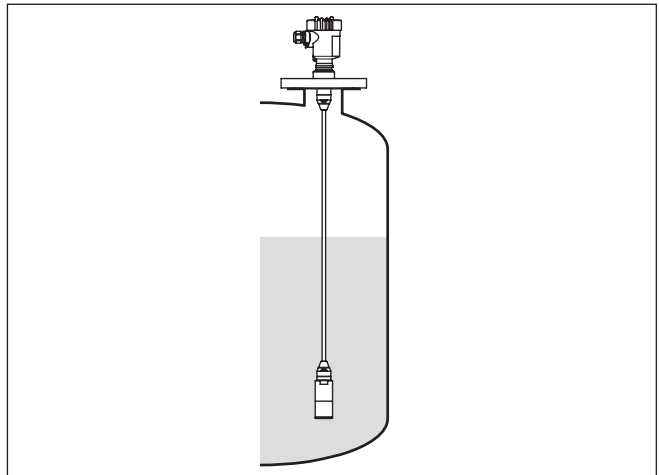

Fig. 2: Level measurement with VEGABAR 87

Measuring system

The process pressure acts on the sensor element via the stainless steel diaphragm and an internal transmission liquid. The process pressure causes a resistance change which is converted into a corresponding output signal and output as measured value.

The METEC® measuring cell is the measuring unit. It consists of the ceramic-capacitive CERTEC® measuring cell and a special, temperature-compensated isolating system.

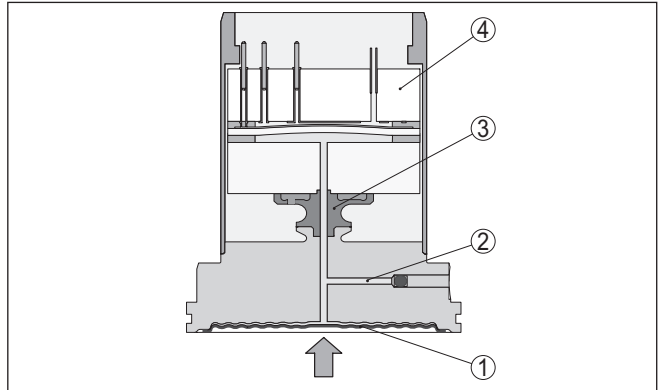

Fig. 3: Configuration of the METEC® measuring cell with VEGABAR 87

- 1 Process diaphragm
- 2 Isolating liquid
- 3 FeNi adapter
- 4 CERTEC® measuring cell

Measuring system temperature

Temperature sensors in the ceramic diaphragm and the ceramic base of the CERTEC® measuring cell detect the actual process temperature. The temperature value is output via:

- The display and adjustment module
- The current output or the additional current output
- The digital signal output

Pressure types

The measuring cell design depends on the selected pressure type.

Relative pressure: the measuring cell is open to the atmosphere. The ambient pressure is detected in the measuring cell and compensated. It thus has no influence on the measured value.

Absolute pressure: the measuring cell contains vacuum and is encapsulated. The ambient pressure is not compensated and does hence influence the measured value.

Relative pressure, climate-compensated: the measuring cell is evacuated and encapsulated. The ambient pressure is detected through a reference sensor in the electronics and compensated. It thus has no influence on the measured value.

Seal concept

The measuring system is completely welded and hence sealed against the process. The sealing of the process fitting against the process is carried out by a seal provided on site.

	<h3>3.3 Packaging, transport and storage</h3>
Packaging	<p>Your instrument was protected by packaging during transport. Its capacity to handle normal loads during transport is assured by a test based on ISO 4180.</p> <p>The packaging consists of environment-friendly, recyclable cardboard. For special versions, PE foam or PE foil is also used. Dispose of the packaging material via specialised recycling companies.</p>
Transport	<p>Transport must be carried out in due consideration of the notes on the transport packaging. Nonobservance of these instructions can cause damage to the device.</p>
Transport inspection	<p>The delivery must be checked for completeness and possible transit damage immediately at receipt. Ascertained transit damage or concealed defects must be appropriately dealt with.</p>
Storage	<p>Up to the time of installation, the packages must be left closed and stored according to the orientation and storage markings on the outside.</p> <p>Unless otherwise indicated, the packages must be stored only under the following conditions:</p> <ul style="list-style-type: none"> ● Not in the open ● Dry and dust free ● Not exposed to corrosive media ● Protected against solar radiation ● Avoiding mechanical shock and vibration
Storage and transport temperature	<ul style="list-style-type: none"> ● Storage and transport temperature see chapter " <i>Supplement - Technical data - Ambient conditions</i> " ● Relative moisture 20 ... 85 %
Lifting and carrying	<p>With instrument weights of more than 18 kg (39.68 lbs) suitable and approved equipment must be used for lifting and carrying.</p>
	<h3>3.4 Accessories</h3> <p>The instructions for the listed accessories can be found in the download area on our homepage.</p>
Display and adjustment module	<p>The display and adjustment module is used for measured value indication, adjustment and diagnosis.</p> <p>The integrated Bluetooth module (optional) enables wireless adjustment via standard adjustment devices.</p>
VEGACONNECT	<p>The interface adapter VEGACONNECT enables the connection of communication-capable instruments to the USB interface of a PC.</p>
Secondary sensors	<p>Secondary sensors of VEGABAR series 80 enable in conjunction with VEGABAR 87 an electronic differential pressure measurement.</p>

VEGADIS 81	The VEGADIS 81 is an external display and adjustment unit for VEGAPLICS® sensors.
VEGADIS adapter	The VEGADIS adapter is an accessory part for sensors with double chamber housing. It enables the connection of VEGADIS 81 to the sensor housing via an M12 x 1 plug.
Protective cover	The protective cover protects the sensor housing against soiling and intense heat from solar radiation.
Flanges	Screwed flanges are available in different versions according to the following standards: DIN 2501, EN 1092-1, BS 10, ASME B 16.5, JIS B 2210-1984, GOST 12821-80.
Welded socket, threaded and hygienic adapter	Welded sockets are used to connect the devices to the process. Threaded and hygienic adapters enable simple adaptation of devices with standard threaded fittings to process-side hygiene connections.

4 Mounting

4.1 General instructions

Process conditions



Note:

For safety reasons, the instrument must only be operated within the permissible process conditions. You can find detailed information on the process conditions in chapter " *Technical data*" of the operating instructions or on the type label.

Hence make sure before mounting that all parts of the instrument exposed to the process are suitable for the existing process conditions.

These are mainly:

- Active measuring component
- Process fitting
- Process seal

Process conditions in particular are:

- Process pressure
- Process temperature
- Chemical properties of the medium
- Abrasion and mechanical influences

Protection against moisture

Protect your instrument against moisture ingress through the following measures:

- Use a suitable connection cable (see chapter " *Connecting to power supply*")
- Tighten the cable gland or plug connector
- Lead the connection cable downward in front of the cable entry or plug connector

This applies mainly to outdoor installations, in areas where high humidity is expected (e.g. through cleaning processes) and on cooled or heated vessels.



Note:

Make sure that during installation or maintenance no moisture or dirt can get inside the instrument.

To maintain the housing protection, make sure that the housing lid is closed during operation and locked, if necessary.

Screwing in

Devices with threaded fitting are screwed into the process fitting with a suitable wrench via the hexagon.

See chapter " *Dimensions*" for wrench size.



Warning:

The housing or the electrical connection may not be used for screwing in! Depending on the device version, tightening can cause damage, e. g. to the rotation mechanism of the housing.

Vibrations

Avoid damages on the device by lateral forces, for example by vibrations. It is thus recommended to fix the devices with process fitting

thread G½ of plastic at the installation site via a suitable measuring instrument holder.

If there is strong vibration at the mounting location, the instrument version with external housing should be used. See chapter "External housing".

Permissible process pressure (MWP) - Device

The permissible process pressure range is specified on the type label with "MWP" (Maximum Working Pressure), see chapter "Configuration". This applies even if a measuring cell with a measuring range (order-related) higher than the permissible pressure range of the process fitting is installed.

In addition, a temperature derating of the process fitting, e. g. with flanges, can limit the permissible process pressure range according to the respective standard.

Permissible process pressure (MWP) - Mounting accessory

The permissible process pressure range is stated on the type label. The instrument should only be operated with these pressures if the mounting accessory used also fulfils these values. This should be ensured by suitable flanges, welded sockets, tension rings with Clamp connections, sealings, etc.

Temperature limits

Higher process temperatures often mean also higher ambient temperatures. Make sure that the upper temperature limits stated in chapter "Technical data" for the environment of the electronics housing and connection cable are not exceeded.

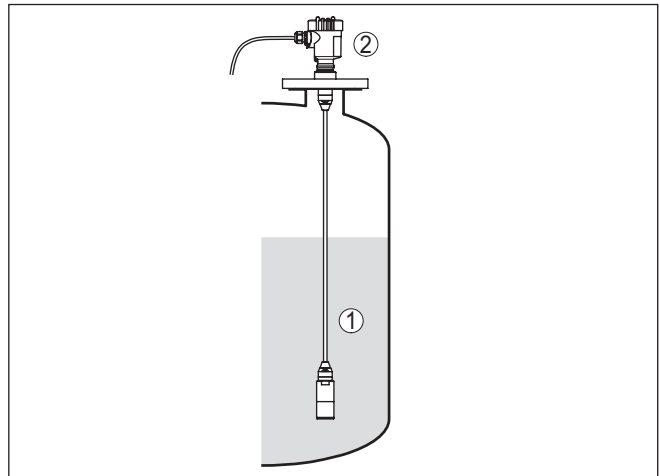

Fig. 4: Temperature ranges

- 1 Process temperature
- 2 Ambient temperature

Transport and mounting protection

Depending on the transmitter, the VEGABAR 87 is supplied with a protective cap or a transport and mounting protection.

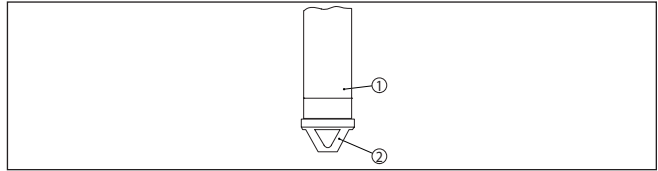

Fig. 5: VEGABAR 87, transport and mounting protection

- 1 Transmitter
2 Transport and mounting protection

Remove this protection after mounting and before setting up the instrument.

In case of slightly contaminated measured media, the transport and mounting protection can remain on the instrument as an impact protection during operation.

4.2 Ventilation and pressure compensation

Filter element - Function

The filter element in the electronics housing has the following functions:

- Ventilation of the electronics housing
- Atmospheric pressure compensation (with relative pressure measuring ranges)



Caution:

The filter element causes a time-delayed pressure compensation. When quickly opening/closing the housing cover, the measured value can change for approx. 5 s by up to 15 mbar.

For an effective ventilation, the filter element must be always free from buildup. In case of horizontal mounting, turn the housing so that the filter element points downward after the instrument is installed. This provides better protection against buildup.



Caution:

Do not use a high-pressure cleaner. The filter element could be damaged, which would allow moisture into the housing.

The following paragraphs describe how the filter element is arranged in the different instrument versions.

Filter element - Position

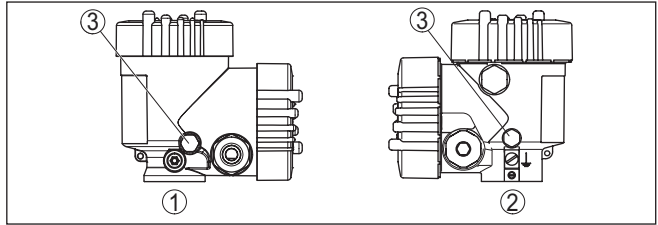

Fig. 6: Position of the filter element

- 1 Plastic double chamber housing
- 2 Aluminium, stainless steel (precision casting) double chamber
- 3 Filter element

4.3 Level measurement

Measurement setup

Keep the following in mind when setting up the measuring system:

- Do not mount the instrument close to the filling stream or emptying area
- Mount the instrument so that it is protected against pressure shocks from the stirrer

4.4 External housing

Configuration

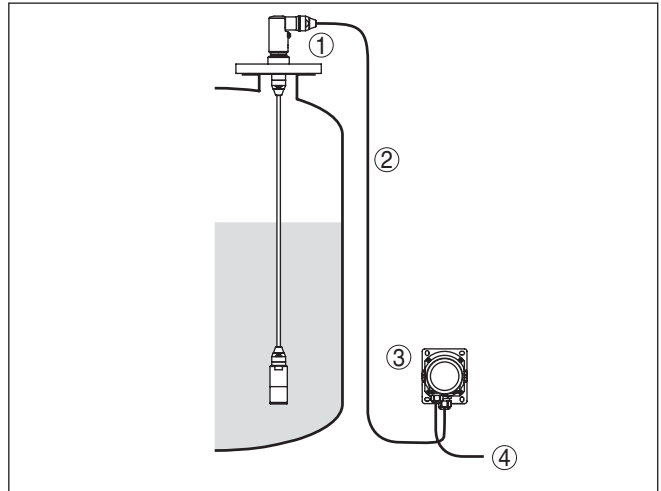

Fig. 7: Arrangement measurement loop, external housing

- 1 Sensor
- 2 Connection cable sensor, external housing
- 3 External housing
- 4 Signal cable

5 Connecting to power supply and bus system

5.1 Preparing the connection

Safety instructions

Always keep in mind the following safety instructions:

- Carry out electrical connection by trained, qualified personnel authorised by the plant operator
- If overvoltage surges are expected, overvoltage arresters should be installed



Warning:

Only connect or disconnect in de-energized state.

Voltage supply

The operating voltage and the digital bus signal are routed via separate two-wire connection cables.

The data for power supply are specified in chapter " *Technical data*".



Note:

Power the instrument via an energy-limited circuit (power max. 100 W) acc. to IEC 61010-1, e.g.

- Class 2 power supply unit (acc. to UL1310)
- SELV power supply unit (safety extra-low voltage) with suitable internal or external limitation of the output current

Connection cable

The instrument is connected with standard two-wire, twisted cable suitable for RS 485. If electromagnetic interference is expected which is above the test values of EN 61326 for industrial areas, shielded cable should be used.

Use cable with round cross section for instruments with housing and cable gland. Use a cable gland suitable for the cable diameter to ensure the seal effect of the cable gland (IP protection rating).

Make sure that the entire installation is carried out according to the Fieldbus specification. In particular, make sure that the bus is terminated with suitable terminating resistors.

Cable screening and grounding

Make sure that the cable screen and grounding are carried out according to Fieldbus specification. We recommend to connect the cable screening to ground potential on both ends.

In systems with potential equalisation, connect the cable screening directly to ground potential at the power supply unit and the sensor. The cable screening in the sensor must be connected directly to the internal ground terminal. The ground terminal outside on the housing must be connected to the potential equalisation (low impedance).

Cable glands

Metric threads:

In the case of instrument housings with metric thread, the cable glands are screwed in at the factory. They are sealed with plastic plugs as transport protection.

Note:
You have to remove these plugs before electrical connection.

NPT thread:

In the case of instrument housings with self-sealing NPT threads, it is not possible to have the cable entries screwed in at the factory. The free openings for the cable glands are therefore covered with red dust protection caps as transport protection.

Note:
Prior to setup you have to replace these protective caps with approved cable glands or close the openings with suitable blind plugs.

On plastic housings, the NPT cable gland or the Conduit steel tube must be screwed into the threaded insert without grease.

Max. torque for all housings, see chapter " *Technical data*".

5.2 Connecting

Connection technology

The voltage supply and signal output are connected via the spring-loaded terminals in the housing.

Connection to the display and adjustment module or to the interface adapter is carried out via contact pins in the housing.

Information:
The terminal block is pluggable and can be removed from the electronics. To do this, lift the terminal block with a small screwdriver and pull it out. When reinserting the terminal block, you should hear it snap in.

Connection procedure

Proceed as follows:

1. Unscrew the housing lid
2. Loosen compression nut of the cable gland and remove blind plug
3. Remove approx. 10 cm (4 in) of the cable mantle (signal output), strip approx. 1 cm (0.4 in) insulation from the ends of the individual wires
4. Insert the cable into the sensor through the cable entry



Fig. 8: Connection steps 5 and 6

5. Insert the wire ends into the terminals according to the wiring plan



Information:

Solid cores as well as flexible cores with wire end sleeves are inserted directly into the terminal openings. In case of flexible cores without end sleeves, press the terminal from above with a small screwdriver, the terminal opening is then free. When the screwdriver is released, the terminal closes again.

6. Check the hold of the wires in the terminals by lightly pulling on them
7. Connect the cable screening to the internal ground terminal, connect the outer ground terminal to potential equalisation in case of power supply via low voltage
8. Connect the lead cable for voltage supply in the same way according to the wiring plan, in addition connect the ground conductor to the inner ground terminal when powered with mains voltage.
9. Tighten the compression nut of the cable entry gland. The seal ring must completely encircle the cable
10. Screw the housing lid back on

The electrical connection is finished.



Information:

The terminal blocks are pluggable and can be removed from the housing insert. To do this, lift the terminal block with a small screwdriver and pull it out. When inserting the terminal block again, you should hear it snap in.

5.3 Wiring plan

Overview

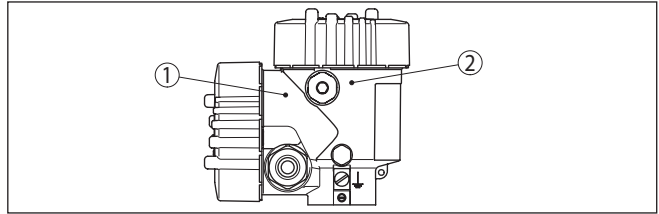

Fig. 9: Position of connection compartment (Modbus electronics) and electronics compartment (sensor electronics)

- 1 Connection compartment
- 2 Electronics compartment

Electronics compartment

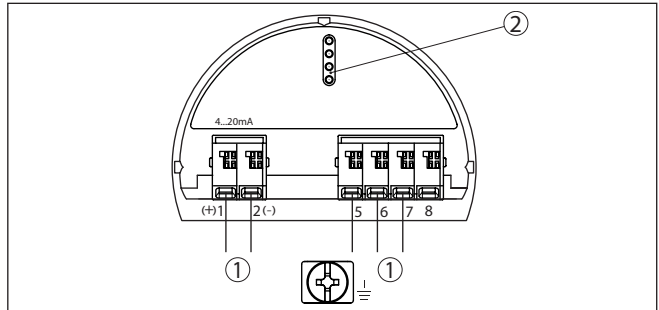

Fig. 10: Electronics compartment - double chamber housing

- 1 Internal connection to the connection compartment
- 2 For display and adjustment module or interface adapter

Connection compartment

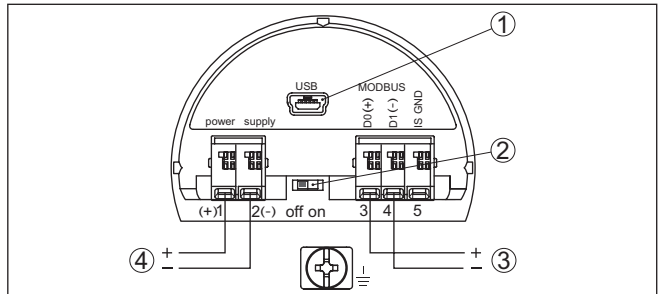

Fig. 11: Connection compartment

- 1 USB interface
- 2 Slide switch for integrated termination resistor (120 Ω)
- 3 Modbus signal
- 4 Voltage supply

Terminal	Function	Polarity
1	Voltage supply	+

Terminal	Function	Polarity
2	Voltage supply	-
3	Modbus signal D0	+
4	Modbus signal D1	-
5	Function ground when installing according to CSA (Canadian Standards Association)	

Terminal compartment, housing socket

5.4 External housing

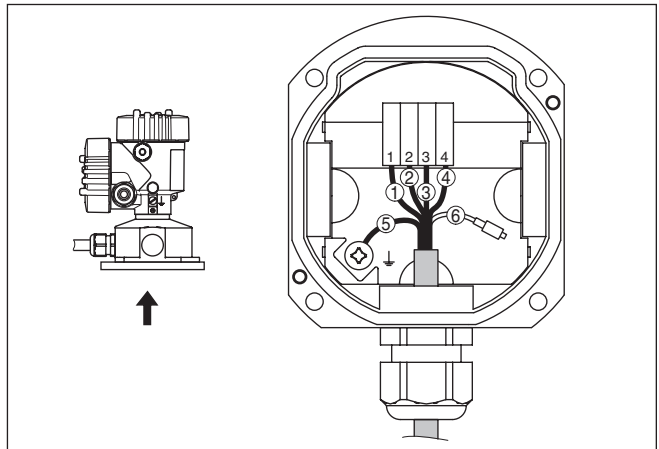

Fig. 12: Connection of the sensor in the housing base

- 1 Yellow
- 2 White
- 3 Red
- 4 Black
- 5 Shielding
- 6 Breather capillaries

Electronics and connection compartment for power supply

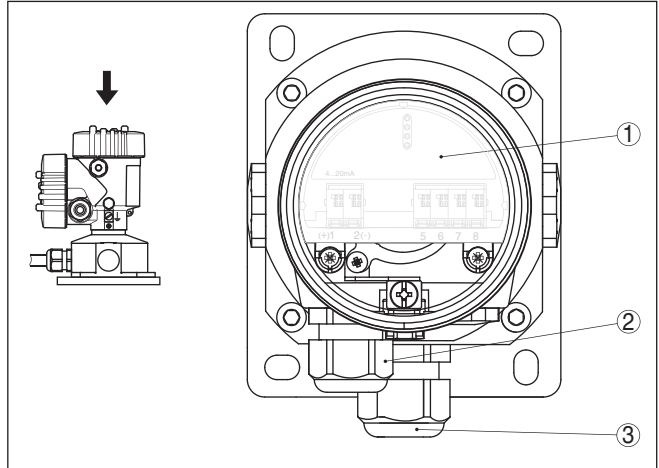

Fig. 13: Electronics and connection compartment

- 1 Electronics module
- 2 Cable gland for voltage supply
- 3 Cable gland for connection cable, transmitter

Overview

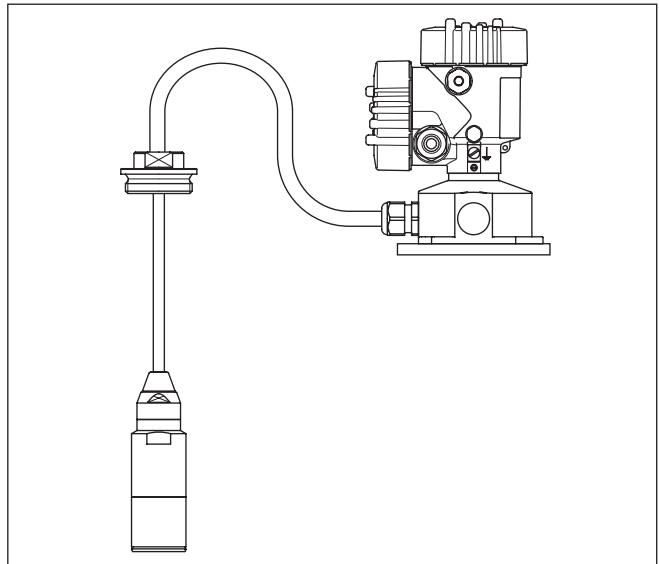

Fig. 14: VEGABAR 87 in IP68 version 25 bar, non-Ex and axial cable outlet, external housing

5.5 Switch-on phase

After connecting the instrument to power supply or after a voltage recurrence, the instrument carries out a self-check:

- Internal check of the electronics
- Indication of a status message on the display or PC

Then the actual measured value is output to the signal cable. The value takes into account settings that have already been carried out, e.g. default setting.

6 Set up the sensor with the display and adjustment module

6.1 Insert display and adjustment module

The display and adjustment module can be inserted into the sensor and removed again at any time. You can choose any one of four different positions - each displaced by 90°. It is not necessary to interrupt the power supply.

Proceed as follows:

1. Unscrew the housing lid
2. Place the display and adjustment module on the electronics in the desired position and turn it to the right until it snaps in.
3. Screw housing lid with inspection window tightly back on

Disassembly is carried out in reverse order.

The display and adjustment module is powered by the sensor, an additional connection is not necessary.



Fig. 15: Insertion of the display and adjustment module



Note:

If you intend to retrofit the instrument with a display and adjustment module for continuous measured value indication, a higher lid with an inspection glass is required.

6.2 Adjustment system

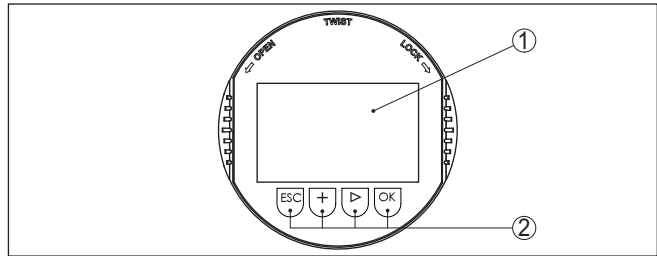

Fig. 16: Display and adjustment elements

- 1 LC display
- 2 Adjustment keys

Key functions

- **[OK]** key:
 - Move to the menu overview
 - Confirm selected menu
 - Edit parameter
 - Save value
- **[>]** key:
 - Change measured value presentation
 - Select list entry
 - Select menu items
 - Select editing position
- **[+]** key:
 - Change value of the parameter
- **[ESC]** key:
 - Interrupt input
 - Jump to next higher menu

Adjustment system

The instrument is operated via the four keys of the display and adjustment module. The individual menu items are shown on the LC display. You can find the function of the individual keys in the previous illustration.

Adjustment system - keys via magnetic pen

With the Bluetooth version of the display and adjustment module you can also adjust the instrument with the magnetic pen. The pen operates the four keys of the display and adjustment module right through the closed lid (with inspection window) of the sensor housing.

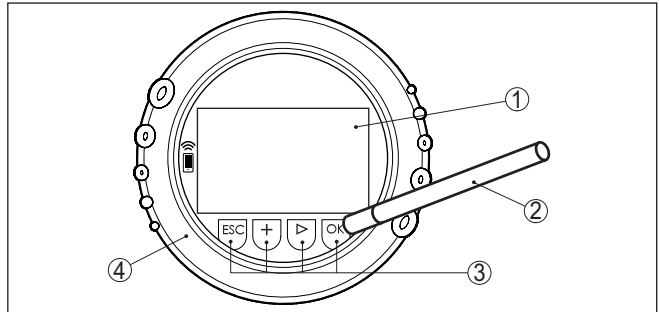

Fig. 17: Display and adjustment elements - with adjustment via magnetic pen

- 1 LC display
- 2 Magnetic pen
- 3 Adjustment keys
- 4 Lid with inspection window

Time functions

When the **[+]** and **[->]** keys are pressed quickly, the edited value, or the cursor, changes one value or position at a time. If the key is pressed longer than 1 s, the value or position changes continuously.

When the **[OK]** and **[ESC]** keys are pressed simultaneously for more than 5 s, the display returns to the main menu. The menu language is then switched over to "English".

Approx. 60 minutes after the last pressing of a key, an automatic reset to measured value indication is triggered. Any values not confirmed with **[OK]** will not be saved.

Measured value indication

6.3 Measured value indication

With the **[->]** key you can move between three different indication modes.

In the first view, the selected measured value is displayed in large digits.

In the second view, the selected measured value and a respective bargraph presentation are displayed.

In the third view, the selected measured value as well as a second selectable value, e.g. the temperature, are displayed.



With the "OK" key you move (during the initial setup of the instrument) to the selection menu "Language".

Selection language

In this menu item, you can select the national language for further parameterization.



With the "[>]" button, you can select the requested language, with "**OK**" you confirm the selection and move to the main menu.

You can change your selection afterwards with the menu item "*Setup - Display, Menu language*".

6.4 Parameter adjustment - Quick setup

To quickly and easily adapt the sensor to the application, select the menu item "*Quick setup*" in the start graphic on the display and adjustment module.



Select the individual steps with the "[>]" key.

After the last step, "*Quick setup terminated successfully*" is displayed briefly.

The return to the measured value indication is carried out through the "[>]" or "[ESC]" keys or automatically after 3 s



Note:

You can find a description of the individual steps in the quick setup guide of the sensor.

You can find "*Extended adjustment*" in the next sub-chapter.

6.5 Parameter adjustment - Extended adjustment

For technically demanding measuring points, you can carry out extended settings in "*Extended adjustment*".

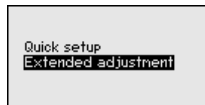

Main menu

The main menu is divided into five sections with the following functions:

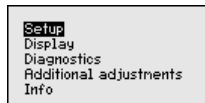

Setup: Settings e. g. for measurement loop name, application, units, position correction, adjustment, signal output, disable/enable operation

Display: Settings, e.g., for language, measured value display, lighting

Diagnosis: Information, for example, of device status, peak indicator, simulation

Additional adjustments: date/time, reset, copy function

Info: Instrument name, hardware and software version, calibration date, sensor features



Note:

For optimum setting of the measuring point, the individual submenu items in the main menu item "Setup" should be selected one after the other and provided with the correct parameters. If possible, go through the items in the given sequence.

The submenu points are described below.

6.5.1 Setup

Measurement loop name

In the menu item "Sensor TAG" you edit a twelve-digit measurement loop designation.

You can enter an unambiguous designation for the sensor, e.g. the measurement loop name or the tank or product designation. In digital systems and in the documentation of larger plants, a singular designation must be entered for exact identification of individual measuring points.

The available digits include:

- Letters from A ... Z
- Numbers from 0 ... 9
- Special characters +, -, /, -

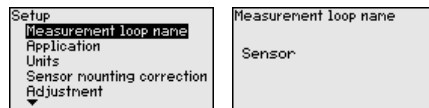

Application

In this menu item you activate/deactivate the Secondary Device for electronic differential pressure and select the application.

VEGABAR 87 can be used for process pressure and level measurement. The setting in the delivery status is "Level". The mode can be changed in this adjustment menu.

If you have connected **no** Secondary Device, you confirm this with "Deactivate".

Depending on the selected application, different subchapters in the following adjustment steps are important. There you can find the individual adjustment steps.

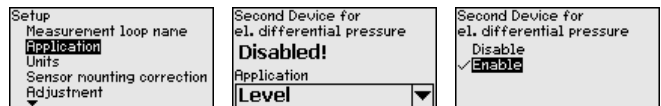

Enter the requested parameters via the appropriate keys, save your settings with [OK] and jump to the next menu item with the [ESC] and the [->] key.

Units

In this menu item, the adjustment units of the instrument are determined. The selection determines the unit displayed in the menu items "*Min. adjustment (Zero)*" and "*Max. adjustment (Span)*".

Unit of measurement:

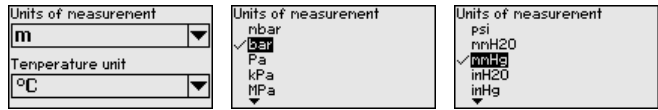

If the level should be adjusted in a height unit, the density of the medium must also be entered later during the adjustment.

In addition, the temperature unit of the instrument is specified. The selection determines the unit displayed in menu items "*Peak indicator, temperature*" and "in the variables of the digital output signal".

Temperature unit:

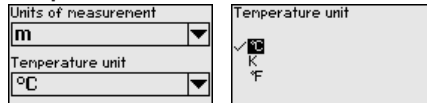

Enter the requested parameters via the appropriate keys, save your settings with **[OK]** and jump to the next menu item with the **[ESC]** and the **[->]** key.

Position correction

Especially with chemical seal systems, the installation position of the instrument can shift (offset) the measured value. Position correction compensates this offset. In the process, the actual measured value is taken over automatically. With relative pressure measuring cells a manual offset can also be carried out.

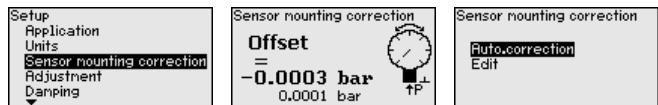

Note:

If the current measured value is automatically accepted, it must not be falsified by medium coverage or static pressure.

With the manual position correction, the offset value can be determined by the user. Select for this purpose the function "*Edit*" and enter the requested value.

Save your settings with **[OK]** and move with **[ESC]** and **[->]** to the next menu item.

After the position correction is carried out, the actual measured value is corrected to 0. The corrective value appears with an inverse sign as offset value in the display.

The position correction can be repeated as often as necessary. However, if the sum of the corrective values exceeds $\pm 50\%$ of the nominal measuring range, then no position correction is possible.

Parameterization example VEGABAR 87 always measures pressure independently of the process variable selected in the menu item "*Application*". To output the

selected process variable correctly, an allocation of the output signal to 0 % and 100 % must be carried out (adjustment).

During adjustment, the pressure is entered e.g. for the level with full and empty vessel, see following example:

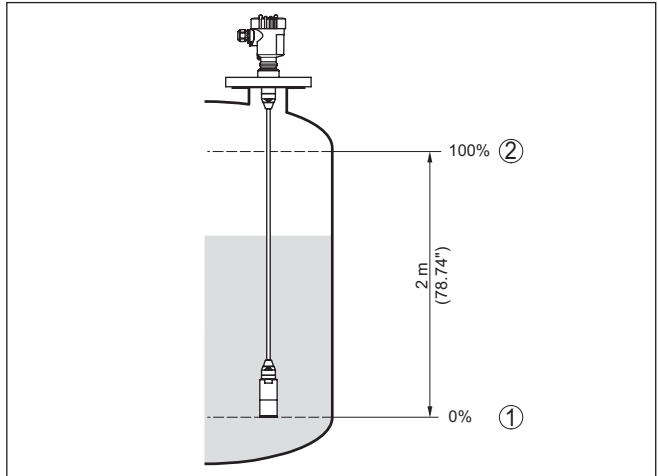

Fig. 18: Parameter adjustment example Min./max. adjustment, level measurement

- 1 Min. level = 0 % corresponds to 0.0 mbar
- 2 Max. level = 100 % corresponds to 196.2 mbar

If these values are not known, an adjustment with filling levels of e.g. 10 % and 90 % is also possible. By means of these settings, the real filling height is then calculated.

The actual product level during the adjustment is not important, because the min./max. adjustment is always carried out without changing the product level. These settings can be made ahead of time without the instrument having to be installed.



Note:

If the adjustment ranges are exceeded, the entered value will not be accepted. Editing can be interrupted with **[ESC]** or corrected to a value within the adjustment ranges.

Min. adjustment - Level

Proceed as follows:

1. Select the menu item "Setup" with **[->]** and confirm with **[OK]**. Now select with **[->]** the menu item "Adjustment", then "Min. adjustment" and confirm with **[OK]**.

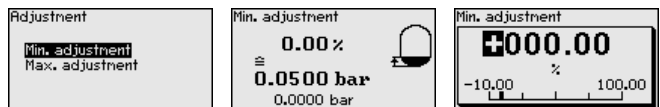

2. Edit the percentage value with **[OK]** and set the cursor to the requested position with **[->]**.

3. Set the requested percentage value (e.g. 10 %) with **[+]** and save with **[OK]**. The cursor jumps now to the pressure value.
4. Enter the pressure value corresponding to the min. level (e.g. 0 mbar).
5. Save settings with **[OK]** and move with **[ESC]** and **[->]** to the max. adjustment.

The min. adjustment is finished.

For an adjustment with filling, simply enter the actual measured value indicated at the bottom of the display.

Max. adjustment - Level

Proceed as follows:

1. Select with **[->]** the menu item "Max. adjustment" and confirm with **[OK]**.



2. Edit the percentage value with **[OK]** and set the cursor to the requested position with **[->]**.
3. Set the requested percentage value (e.g. 90 %) with **[+]** and save with **[OK]**. The cursor jumps now to the pressure value.
4. Enter the pressure value for the full vessel (e.g. 900 mbar) corresponding to the percentage value.
5. Save settings with **[OK]**

The max. adjustment is finished.

For an adjustment with filling, simply enter the actual measured value indicated at the bottom of the display.

Damping

To damp process-dependent measured value fluctuations, set an damping of 0 ... 999 s in this menu item. The increment is 0.1 s.

The set damping is effective for level and process pressure measurement as well as for all applications of electronic differential pressure measurement.

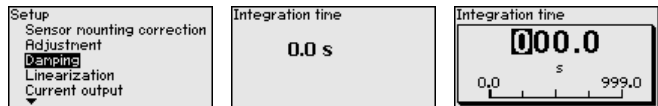

The default setting is a damping of 0 s.

Linearisation

A linearization is necessary for all vessels in which the vessel volume does not increase linearly with the level - e.g. a horizontal cylindrical or spherical tank - and the indication or output of the volume is required. Corresponding linearization curves are preprogrammed for these vessels. They represent the correlation between the level percentage and vessel volume. The linearization applies to the measured value indication and the current output.

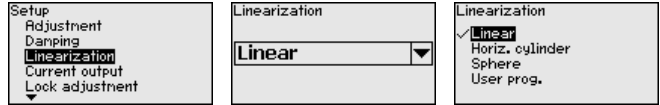

With flow measurement and selection " *Linear*" display and output (percentage/current) are linear to " **Differential pressure**". This can be used, for example, to feed a flow computer.

With flow measurement and selection " *Extraction by root*" display and output (percentage/current) are linear to " **Flow**".¹⁾

With flow in two directions (bidirectional) a negative differential pressure is also possible. This must already be taken into account in menu item " *Min. adjustment flow*".



Caution:

Note the following, if the respective sensor is used as part of an over-fill protection system according to WHG:

If a linearisation curve is selected, the measuring signal is no longer necessarily linear to the filling height. This must be considered by the user especially when setting the switching point on the limit signal transmitter.

Lock/Unlock adjustment

In the menu item " *Lock/unlock adjustment*" you safeguard the sensor parameters against unauthorized or unintentional modifications.

This is done by entering a four-digit PIN.

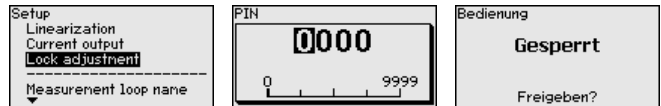

With active PIN, only the following adjustment functions are possible without entering a PIN:

- Select menu items and show data
- Read data from the sensor into the display and adjustment module

Releasing the sensor adjustment is also possible in any menu item by entering the PIN.



Caution:

With active PIN, adjustment via PACTware/DTM and other systems is also blocked.

6.5.2 Display

Language

This menu item enables the setting of the requested national language.

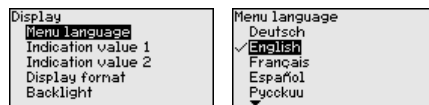

¹⁾ The device assumes an approximately constant temperature and static pressure and converts the differential pressure into the flow rate via the characteristic curve extracted by root.

The following languages are available:

- German
- English
- French
- Spanish
- Russian
- Italian
- Dutch
- Portuguese
- Japanese
- Chinese
- Polish
- Czech
- Turkish

In delivery status, the VEGABAR 87 is set to English.

Display value 1 and 2

In this menu item, you define which measured value is displayed.

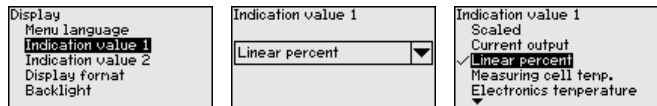

The setting in the delivery status for the display value is " *Lin. percent*".

Display format 1 and 2

In this menu item you define the number of decimal positions with which the measured value is displayed.

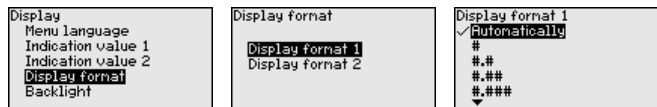

The setting in the delivery status for the display format is " *Automatic*".

Backlight

The display and adjustment module has a backlight for the display. In this menu item you can switch on the lighting. You can find the required operating voltage in chapter " *Technical data*".

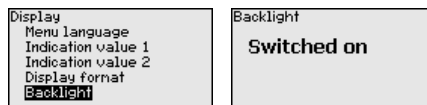

In delivery status, the lighting is switched on.

Device status

In this menu item, the device status is displayed.

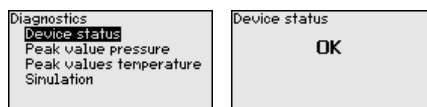

In case of error, e.g. the error code F017, e.g. the error description " *Adjustment span too small*" and a four digit figure are displayed for

service purposes. You can find the error codes with description, reason as well as rectification in chapter "Asset Management".

Peak indicator, pressure

The respective min. and max. measured values are saved in the sensor. The two values are displayed in menu item "Peak indicator, pressure".

In another window you can carry out a reset of the peak values separately.

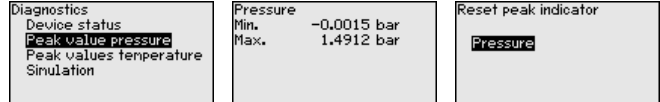

Peak indicator, temperature

The respective min. and max. measured values of the measuring cell and the electronics temperature are stored in the sensor. In menu item "Peak indicator, temperature", both values are displayed.

In another window you can carry out a reset of the two peak values separately.

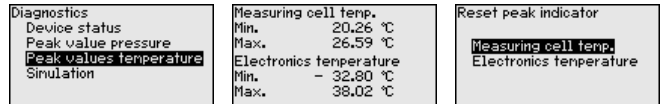

Simulation

In this menu item you simulate measured values. Hence, the signal path can be tested via the bus system to the input card of the control system.

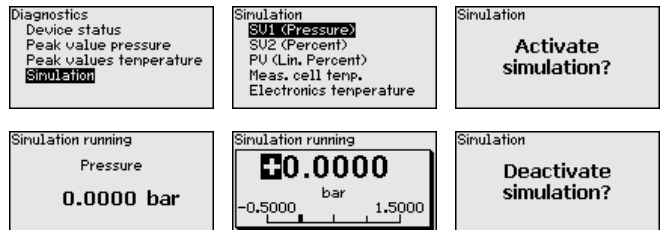

Select the requested simulation variable and set the requested value.

To deactivate the simulation, you have to push the **[ESC]** key and confirm the message "Deactivate simulation" with the **[OK]** key.



Caution:

During simulation, the simulated value is output as digital signal. The status message along with the Asset Management function is "Maintenance".



Information:

The sensor terminates the simulation automatically after 60 minutes.

6.5.3 Additional adjustments

Date/Time

In this menu item, you adjust the internal clock of the sensor. There is no adjustment for summer/winter (daylight saving) time.

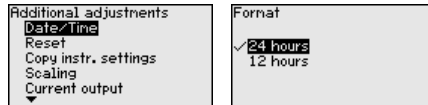

Reset

After a reset, certain parameter adjustments made by the user are reset.

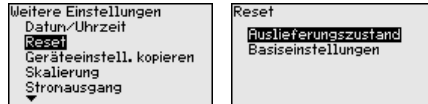

The following reset functions are available:

Delivery status: Restores the parameter settings at the time of shipment from the factory, incl. the order-specific settings. Any user-defined linearisation curve as well as the measured value memory are deleted.

Basic settings: Resets the parameter settings, incl. special parameters, to the default values of the respective instrument. Any programmed linearisation curve as well as the measured value memory are deleted.



Note:

You can find the default values of the device in chapter " *Menu overview*".

Copy instrument settings

The instrument settings are copied with this function. The following functions are available:

- **Read from sensor:** Read data from sensor and store into the display and adjustment module
- **Write into sensor:** Store data from the display and adjustment module back into the sensor

The following data or settings for adjustment of the display and adjustment module are saved:

- All data of the menu " *Setup*" and " *Display*"
- In the menu " *Additional adjustments*" the items " *Reset*, *Date/Time*"
- The user-programmable linearization curve

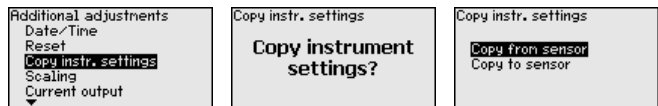

The copied data are permanently saved in an EEPROM memory in the display and adjustment module and remain there even in case of power failure. From there, they can be written into one or more sensors or kept as backup for a possible electronics exchange.



Note:

Before the data are saved in the sensor, a safety check is carried out to determine if the data match the sensor. In the process the sensor

type of the source data as well as the target sensor are displayed. If the data do not match, a fault message is outputted or the function is blocked. The data are saved only after release.

Special parameters

In this menu item you gain access to the protected area where you can enter special parameters. In exceptional cases, individual parameters can be modified in order to adapt the sensor to special requirements.

Change the settings of the special parameters only after having contacted our service staff.

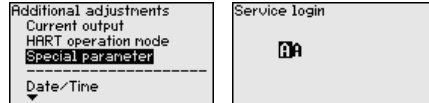

Scaling (1)

In menu item "Scaling" you define the scaling variable and the scaling unit for the level value on the display, e.g. volume in l.

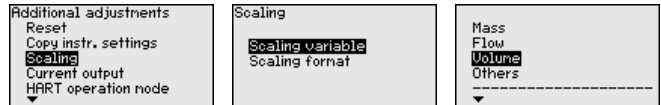

Scaling (2)

In menu item "Scaling (2)" you define the scaling format on the display and the scaling of the measured level value for 0 % and 100 %.

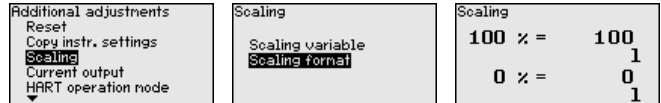

6.5.4 Info

Device name

In this menu item, you can read out the instrument name and the instrument serial number:

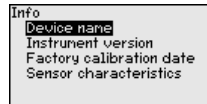

Instrument version

In this menu item, the hardware and software version of the sensor is displayed.

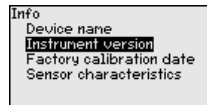

Factory calibration date

In this menu item, the date of factory calibration of the sensor as well as the date of the last change of sensor parameters are displayed via the display and adjustment module or via the PC.

Info
Device name
Instrument version
Factory calibration date
Sensor characteristics

Sensor characteristics

In this menu item, the features of the sensor such as approval, process fitting, seal, measuring range, electronics, housing and others are displayed.

Info
Device name
Instrument version
Factory calibration date
Sensor characteristics

6.6 Menu overview

The following tables show the adjustment menu of the instrument. Depending on the instrument version or application, all menu items may not be available or some may be differently assigned.

Setup

Menu item	Parameter	Default value
Measurement loop name		Sensor
Application	Application	Level
	Secondary sensor for electronic differential pressure	Deactivated
Units	Unit of measurement	mbar (with nominal measuring range ≤ 400 mbar) bar (with nominal measuring ranges ≥ 1 bar)
	Temperature unit	°C
Position correction		0.00 bar
Adjustment	Zero/Min. adjustment	0.00 bar 0.00 %
	Span/Max. adjustment	Nominal measuring range in bar 100.00 %
Damping	Integration time	1 s
Lock adjustment	Blocked, released	Released

Display

Menu item	Default value
Menu language	Selected language
Displayed value 1	Current output in %
Displayed value 2	Ceramic measuring cell: Measuring cell temperature in °C Metallic measuring cell: Electronics temperature in °C
Display format	Number of positions after the decimal point, automatically

Menu item	Default value
Backlight	Switched on

Diagnostics

Menu item	Parameter	Default value
Device status		-
Peak indicator	Pressure	Current pressure measured value
Peak indicator temp.	Temperature	Actual measuring cell and electronic temperature
Simulation		Process pressure

Additional adjustments

Menu item	Parameter	Default value
Date/Time		Actual date/Actual time
Reset	Delivery status, basic settings	
Copy instrument settings	Read from sensor, write into sensor	
Scaling	Scaling size	Volume in l
	Scaling format	0 % corresponds to 0 l 100 % corresponds to 100 l
Special parameters	Service-Login	No reset

Info

Menu item	Parameter
Device name	VEGABAR 87
Instrument version	Hardware and software version
Factory calibration date	Date
Sensor characteristics	Order-specific characteristics

6.7 Save parameter adjustment data

On paper

We recommend writing down the adjustment data, e.g. in this operating instructions manual, and archiving them afterwards. They are thus available for multiple use or service purposes.

In the display and adjustment module

If the instrument is equipped with a display and adjustment module, the parameter adjustment data can be saved therein. The procedure is described in menu item " *Copy device settings*".

7 Setting up sensor and Modbus interface with PACTware

7.1 Connect the PC

To the sensor electronics Connection of the PC to the sensor electronics is carried out via the interface adapter VEGACONNECT.

Scope of the parameter adjustment:

- Sensor electronics

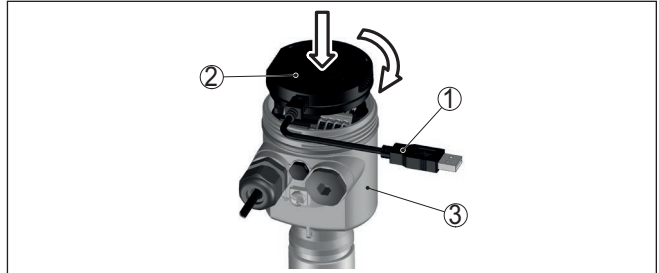

Fig. 19: Connection of the PC directly to the sensor via the interface adapter

- 1 USB cable to the PC
- 2 Interface adapter VEGACONNECT
- 3 Sensor

To the Modbus electronics

Connection of the PC to the Modbus electronics is carried out via a USB cable.

Scope of the parameter adjustment:

- Sensor electronics
- Modbus electronics



Fig. 20: Connecting the PC via USB to the Modbus electronics

- 1 USB cable to the PC

To the RS 485 cable

Connection of the PC to the RS 485 cable is carried out via a standard interface adapter RS 485/USB.

Scope of the parameter adjustment:

- Sensor electronics
- Modbus electronics



Information:

For parameter adjustment, it is absolutely necessary to disconnect from the RTU.

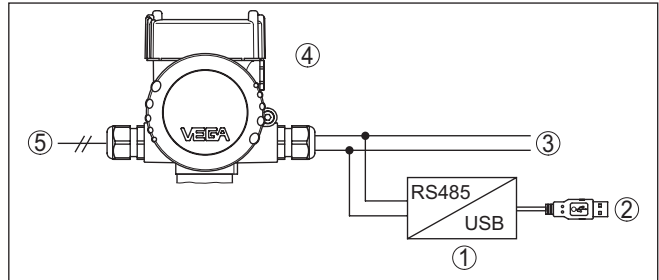

Fig. 21: Connection of the PC via the interface adapter to the RS 485 cable

- 1 Interface adapter RS 485/USB
- 2 USB cable to the PC
- 3 RS 485 cable
- 4 Sensor
- 5 Voltage supply

7.2 Parameterization

Prerequisites

For parameter adjustment of the instrument via a Windows PC, the configuration software PACTware and a suitable instrument driver (DTM) according to FDT standard are required. The latest PACTware version as well as all available DTMs are compiled in a DTM Collection. The DTMs can also be integrated into other frame applications according to FDT standard.



Note:

To ensure that all instrument functions are supported, you should always use the latest DTM Collection. Furthermore, not all described functions are included in older firmware versions. You can download the latest instrument software from our homepage. A description of the update procedure is also available in the Internet.

Further setup steps are described in the operating instructions manual "DTM Collection/PACTware" attached to each DTM Collection and which can also be downloaded from the Internet. Detailed descriptions are available in the online help of PACTware and the DTMs.

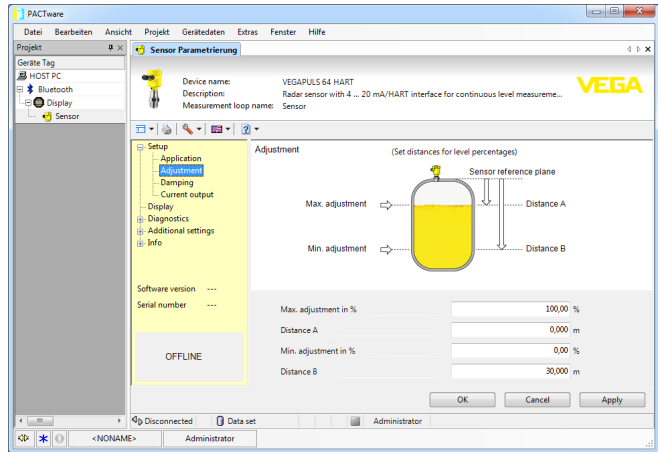

Fig. 22: Example of a DTM view

7.3 Set instrument address

The VEGABAR 87 requires an address for participating as a sensor in the Modbus communication. The address setting is carried out via a PC with PACTware/DTM or Modbus RTU.

The default settings for the address are:

- Modbus: 246
- Levelmaster: 31



Note:

The setting of the instrument address can only be carried out online.

Via PC through Modbus electronics

Start the project assistant and wait until the project tree has been set up. Then, in the project tree, go to the symbol for the Modbus gateway. Select with the right mouse key "*Parameter*", then "*Online parameter adjustment*" and start the DTM for the Modbus electronics.

In the menu bar of the DTM, go to the list arrow next to the symbol for "*Screwdriver*". Select the menu item "*Change address in the instrument*" and set the requested address.

Via PC through RS 485 cable

In the device catalogue, select the option "*Modbus Serial*" under "*Driver*". Double click on this driver and integrate it into the project tree.

Open the device manager on your PC and find out which COM interface the USB/RS 485 adapter is located on. Then go to the symbol "*Modbus COM*." in the project tree. Select "*Parameter*" with the right mouse key and start the DTM for the USB/RS 485 adapter. Enter the COM interface no. from the device manager under "*Basic settings*".

Select with the right mouse key "*Additional functions*" and "*Instrument search*". The DTM then searches for the connected Modbus participants and integrates them into the project tree. Now, in the project tree, go to the symbol for the Modbus gateway. Select with the

right mouse key "*Parameter*", then "*Online parameter setting*" and start the DTM for the Modbus electronics.

In the menu bar of the DTM, go to the list arrow next to the symbol for "*Screwdriver*". Select the menu item "*Change address in the instrument*" and set the requested address.

Then move again to the symbol "*Modbus COM.*" in the project tree. Select with the right mouse key "*Additional functions*" and "*Change DTM addresses*". Enter here the modified address of the Modbus gateway.

Via Modbus-RTU

The instrument address is set in register no. 200 of the Holding Register (see chapter "*Modbus register*" in this operating instructions manual).

The procedure depends on the respective Modbus-RTU and the configuration tool.

7.4 Save parameter adjustment data

We recommend documenting or saving the parameterisation data via PACTware. That way the data are available for multiple use or service purposes.

8 Diagnosis, asset management and service

8.1 Maintenance

Maintenance

If the device is used properly, no special maintenance is required in normal operation.

Precaution measures against buildup

In some applications, product buildup on the diaphragm can influence the measuring result. Depending on the sensor and application, take precautions to ensure that heavy buildup, and especially a hardening thereof, is avoided.

Cleaning

The cleaning helps that the type label and markings on the instrument are visible.

Take note of the following:

- Use only cleaning agents which do not corrode the housings, type label and seals
- Use only cleaning methods corresponding to the housing protection rating

8.2 Diagnosis memory

The instrument has several memories available for diagnostic purposes. The data remain there even in case of voltage interruption.

Measured value memory

Up to 100,000 measured values can be stored in the sensor in a ring memory. Each entry contains date/time as well as the respective measured value.

Depending on the instrument version, values that can be stored are for example:

- Level
- Process pressure
- Differential pressure
- Static pressure
- Percentage value
- Scaled values
- Current output
- Lin. percent
- Measuring cell temperature
- Electronics temperature

When the instrument is shipped, the measured value memory is active and stores pressure value and measuring cell temperature every 10 s, with electronic differential pressure also the static pressure.

The requested values and recording conditions are set via a PC with PACTware/DTM or the control system with EDD. Data are thus read out and also reset.

Event memory

Up to 500 events are automatically stored with a time stamp in the sensor (non-deletable). Each entry contains date/time, event type, event description and value.

Event types are for example:

- Modification of a parameter
- Switch-on and switch-off times
- Status messages (according to NE 107)
- Error messages (according to NE 107)

The data are read out via a PC with PACTware/DTM or the control system with EDD.

8.3 Asset Management function

The instrument features self-monitoring and diagnostics according to NE 107 and VDI/VDE 2650. In addition to the status messages in the following tables there are more detailed error messages available under the menu item "Diagnostics" via the respective adjustment module.

Status messages

The status messages are divided into the following categories:

- Failure
- Function check
- Out of specification
- Maintenance required

and explained by pictographs:

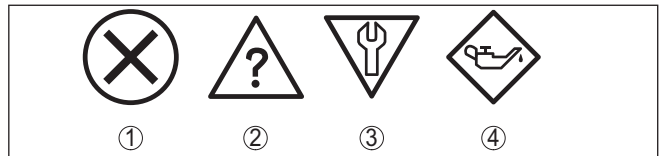

Fig. 23: Pictographs of the status messages

- 1 Failure - red
- 2 Out of specification - yellow
- 3 Function check - orange
- 4 Maintenance required - blue

Malfunction (Failure):

Due to a malfunction in the instrument, a fault signal is output.

This status message is always active. It cannot be deactivated by the user.

Function check:

The instrument is being worked on, the measured value is temporarily invalid (for example during simulation).

This status message is inactive by default.

Out of specification:

The measured value is unreliable because an instrument specification was exceeded (e.g. electronics temperature).

This status message is inactive by default.

Maintenance required:

Due to external influences, the instrument function is limited. The measurement is affected, but the measured value is still valid. Plan in

maintenance for the instrument because a failure is expected in the near future (e.g. due to buildup).

This status message is inactive by default.

Failure

Code Text message	Cause	Rectification
F013 No valid measured value available	Gauge pressure or low pressure Measuring cell defective	Exchange measuring cell Send instrument for repair
F017 Adjustment span too small	Adjustment not within specification	Change the adjustment according to the limit values
F025 Error in the linearization table	Index markers are not continuously rising, for example illogical value pairs	Check linearization table Delete table/Create new
F036 no operable sensor software	Failed or interrupted software update	Repeat software update Check electronics version Exchanging the electronics Send instrument for repair
F040 Error in the electronics	Hardware defect	Exchanging the electronics Send instrument for repair
F041 Communication error	No connection to the sensor electronics	Check connection between sensor and main electronics (with separate version)
F080 General software error	General software error	Disconnect operating voltage briefly
F105 Measured value is determined	The instrument is still in the switch-on phase, the measured value could not yet be determined	Wait for the end of the switch-on phase
F113 Communication error	Error in the internal instrument communication	Disconnect operating voltage briefly Send instrument for repair
F260 Error in the calibration	Error in the calibration carried out in the factory Error in the EEPROM	Exchanging the electronics Send instrument for repair
F261 Error in the instrument settings	Error during setup Error when carrying out a reset	Repeat setup Repeat reset
F264 Installation/Setup error	Inconsistent settings (e.g.: distance, adjustment units with application process pressure) for selected application Invalid sensor configuration (e.g.: application electronic differential pressure with connected differential pressure measuring cell)	Modify settings Modify connected sensor configuration or application
F265 Measurement function disturbed	Sensor no longer carries out a measurement	Carry out a reset Disconnect operating voltage briefly

Function check

Code Text message	Cause	Rectification
C700 Simulation active	A simulation is active	Finish simulation Wait for the automatic end after 60 mins.

Out of specification

Code Text message	Cause	Rectification
S600 Impermissible electronics temperature	Temperature of the electronics in the non-specified range	Check ambient temperature Insulate electronics Use instrument with higher temperature range
S603 Impermissible operating voltage	Operating voltage below specified range	Check electrical connection If necessary, increase operating voltage
S605 Impermissible pressure value	Measured process pressure below or above the adjustment range	Check nominal measuring range of the instrument If necessary, use an instrument with a higher measuring range

Tab. 9: Error codes and text messages, information on causes as well as corrective measures

Maintenance

Code Text message	Cause	Rectification	DevSpec State in CMD 48
M500 Error in the delivery status	The data could not be restored during the reset to delivery status	Repeat reset Load XML file with sensor data into the sensor	Bit 0 of Byte 14 ... 24
M501 Error in the non-active linearisation table	Index markers are not continuously rising, for example illogical value pairs	Check linearization table Delete table/Create new	Bit 1 of Byte 14 ... 24
M502 Error in the event memory	Hardware error EEPROM	Exchanging the electronics Send instrument for repair	Bit 2 of Byte 14 ... 24
M504 Error at a device interface	Hardware defect	Exchanging the electronics Send instrument for repair	Bit 3 of Byte 14 ... 24
M507 Error in the instrument settings	Error during setup Error when carrying out a reset	Carry out reset and repeat setup	Bit 4 of Byte 14 ... 24

8.4 Rectify faults

Reaction when malfunction occurs

The operator of the system is responsible for taking suitable measures to rectify faults.

Fault rectification

The first measures are:

- Evaluation of fault messages
- Checking the output signal
- Treatment of measurement errors

A smartphone/tablet with the adjustment app or a PC/notebook with the software PACTware and the suitable DTM offer you further comprehensive diagnostic possibilities. In many cases, the causes can be determined in this way and the faults eliminated.

Reaction after fault rectification

Depending on the reason for the fault and the measures taken, the steps described in chapter " *Setup* " must be carried out again or must be checked for plausibility and completeness.

24 hour service hotline

Should these measures not be successful, please call in urgent cases the VEGA service hotline under the phone no. **+49 1805 858550**.

The hotline is also available outside normal working hours, seven days a week around the clock.

Since we offer this service worldwide, the support is provided in English. The service itself is free of charge, the only costs involved are the normal call charges.

8.5 Exchange process module on version IP68 (25 bar)

On version IP68 (25 bar), the user can exchange the process module on site. Connection cable and external housing can be kept.

Required tools:

- Hexagon key wrench, size 2

**Caution:**

The exchange may only be carried out in the complete absence of line voltage.



In Ex applications, only a replacement part with appropriate Ex approval may be used.

**Caution:**

During exchange, protect the inner side of the parts against contamination and moisture.

Proceed as follows when carrying out the exchange:

1. Loosen the fixing screw with the hexagon key wrench
2. Carefully detach the cable assembly from the process module

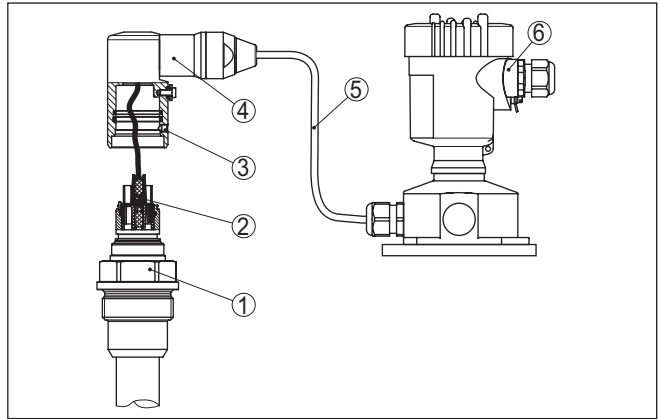

Fig. 24: VEGABAR 87 in IP68 version, 25 bar and lateral cable outlet, external housing

- 1 Process module
- 2 Plug connector
- 3 Cable assembly
- 4 Connection cable
- 5 External housing

3. Loosen the plug connector
 4. Mount the new process module on the measuring point
 5. Plug the connector back in
 6. Mount the cable assembly on the process module and turn it to the desired position
 7. Tighten the fixing screw with the hexagon key wrench
- The exchange is finished.

8.6 Exchanging the electronics module

In case of a defect, the user can replace the electronics module with another one of identical type.



In Ex applications, only instruments and electronics modules with appropriate Ex approval may be used.

You can find detailed information you need to carry out an electronics exchange in the handbook of the electronics module.

8.7 Software update

The following components are required to update the instrument software:

- Instrument
- Voltage supply
- Interface adapter VEGACONNECT
- PC with PACTware
- Current instrument software as file

You can find the current instrument software as well as detailed information on the procedure in the download area of our homepage: www.vega.com.

You can find information about the installation in the download file.

**Caution:**

Instruments with approvals can be bound to certain software versions. Therefore make sure that the approval is still effective after a software update is carried out.

You can find detailed information in the download area at www.vega.com.

8.8 How to proceed if a repair is necessary

On our homepage you will find detailed information on how to proceed in the event of a repair.

So that we can carry out the repair quickly and without queries, generate a instrument return form there with the data of your device.

You will need:

- The serial number of the instrument
- A short description of the problem
- Details of the medium

Print the generated instrument return form.

Clean the instrument and pack it damage-proof.

Send the printed instrument return form and possibly a safety data sheet together with the device.

You will find the address for the return on the generated instrument return form.

9 Dismount

9.1 Dismounting steps

To remove the device, carry out the steps in chapters " *Mounting*" and " *Connecting to power supply*" in reverse.



Warning:

When dismantling, pay attention to the process conditions in vessels or pipelines. There is a risk of injury, e.g. due to high pressures or temperatures as well as aggressive or toxic media. Avoid this by taking appropriate protective measures.

9.2 Disposal



Pass the instrument on to a specialised recycling company and do not use the municipal collecting points.

Remove any batteries in advance, if they can be removed from the device, and dispose of them separately.

If personal data is stored on the old device to be disposed of, delete it before disposal.

If you have no way to dispose of the old instrument properly, please contact us concerning return and disposal.

10 Supplement

10.1 Technical data

Note for approved instruments

The technical data in the respective safety instructions which are included in delivery are valid for approved instruments (e.g. with Ex approval). These data can differ from the data listed herein, for example regarding the process conditions or the voltage supply.

All approval documents can be downloaded from our homepage.

Materials, weights, tensile force

Materials, wetted parts

Process fitting	316L
Transmitter	316L
Suspension cable	FEP
Seal, suspension cable	FKM, FEP
Connection tube	316L
Diaphragm	Alloy C276 (2.4819)
Protective cap	PFA
Seal for process fitting (in the scope of delivery)	
– Thread G1½ (DIN 3852-A)	Klingersil C-4400
– Threaded fitting	Klingersil C-4400

Materials, non-wetted parts

Isolating liquid	Essomarcil (medical white oil, FDA-approved)
Straining clamp	1.4301
Screw connection for suspension cable	316L
Sensor housing	
– Housing	Plastic PBT (Polyester), Aluminium AlSi10Mg (powder-coated, basis: Polyester), 316L
– Cable gland	PA, stainless steel, brass
– Cable gland: Seal, closure	NBR, PA
– Seal, housing lid	Silicone SI 850 R, NBR silicone-free
– Inspection window housing cover	Polycarbonate (UL-746-C listed), glass ²⁾
– Ground terminal	316L
External housing - deviating materials	
– Housing and socket	Plastic PBT (Polyester), 316L
– Socket seal	EPDM
– Seal below wall mounting plate ³⁾	EPDM
– Inspection window housing cover	Polycarbonate (UL-746-C listed)
Ground terminal	316Ti/316L

²⁾ Glass with Aluminium and stainless steel (precision casting) housing

³⁾ Only for 316L with 3A approval

Connection cable with IP68 (25 bar) version ⁴⁾

- Cable cover PE, PUR
- Type label support on cable PE hard

Materials, transmitter protection

- Transport and mounting protection PFA
- transport protection net PE

Weights

- Basic weight 0.7 kg (1.543 lbs)
- Suspension cable 0.1 kg/m (0.07 lbs/ft)
- Connection tube 1.5 kg/m (1 lbs/ft)
- Straining clamp 0.2 kg (0.441 lbs)
- Threaded fitting 0.4 kg (0.882 lbs)

Tensile force

- Tensile force suspension cable max. 500 N (112.4045 lbf)

Torques

Max. torque for process fitting

- G1½ 200 Nm (147.5 lbf ft)

Max. torque for NPT cable glands and Conduit tubes

- Plastic housing 10 Nm (7.376 lbf ft)
- Aluminium/Stainless steel housing 50 Nm (36.88 lbf ft)

Input variable

The specifications are only an overview and refer to the measuring cell. Limitations due to the material and version of the process fitting as well as the selected pressure type are possible. The specifications on the nameplate apply. ⁵⁾

Nominal measuring ranges and overload capability in bar/kPa

Nominal range	Overload capability	
	Maximum pressure	Minimum pressure
Gauge pressure		
0 ... +0.1 bar/0 ... +10 kPa	+15 bar/+1500 kPa	-1 bar/-100 kPa
0 ... +0.4 bar/0 ... +40 kPa	+25 bar/+2500 kPa	-1 bar/-100 kPa
0 ... +1 bar/0 ... +100 kPa	+25 bar/+2500 kPa	-1 bar/-100 kPa
0 ... +2.5 bar/0 ... +250 kPa	+25 bar/+2500 kPa	-1 bar/-100 kPa
0 ... +10 bar/0 ... +1000 kPa	+25 bar/+2500 kPa	-1 bar/-100 kPa
0 ... +25 bar/0 ... +2500 kPa	+25 bar/+2500 kPa	-1 bar/-100 kPa
Absolute pressure		
0 ... 1 bar/0 ... 100 kPa	25 bar/+2500 kPa	0 bar abs.

⁴⁾ Between transmitter and external electronics housing.

⁵⁾ Data on overload capability apply for reference temperature.

Nominal range	Overload capability	
	Maximum pressure	Minimum pressure
0 ... 2.5 bar/0 ... 250 kPa	25 bar/+2500 kPa	0 bar abs.
0 ... 10 bar/0 ... 1000 kPa	25 bar/+2500 kPa	0 bar abs.
0 ... 25 bar/0 ... 2500 kPa	25 bar/+2500 kPa	0 bar abs.

Nominal measuring ranges and overload capacity in psi

Nominal range	Overload capability	
	Maximum pressure	Minimum pressure
Gauge pressure		
0 ... +1.5 psig	+225 psig	-14.51 psig
0 ... +5 psig	+360 psig	-14.51 psig
0 ... +15 psig	+360 psig	-14.51 psig
0 ... +30 psig	+360 psig	-14.51 psig
0 ... +150 psig	+360 psig	-14.51 psig
0 ... +300 psig	+360 psig	-14.51 psig
Absolute pressure		
0 ... 15 psi	360 psi	0 psi
0 ... 30 psi	360 psi	0 psi
0 ... 150 psi	360 psi	0 psi
0 ... 300 psi	360 psi	0 psi

Adjustment ranges

Specifications refer to the nominal measuring range, pressure values lower than -1 bar cannot be set

Min./Max. adjustment:

- Percentage value -10 ... 110 %
- Pressure value -20 ... 120 %

Zero/Span adjustment:

- Zero -20 ... +95 %
- Span -120 ... +120 %
- Difference between zero and span max. 120 % of the nominal range

Max. permissible Turn Down Unlimited (recommended 20 : 1)

Switch-on phase

Run-up time approx. 23 s

Output variable

Output

- Physical layer Digital output signal according to standard EIA-485

<ul style="list-style-type: none"> - Bus specifications - Data protocols <p>Max. transmission rate</p>	<p>Modbus Application Protocol V1.1b3, Modbus over serial line V1.02</p> <p>Modbus RTU, Modbus ASCII, Levelmaster</p> <p>57.6 Kbit/s</p>
--	--

Dynamic behaviour output

Dynamic characteristics depending on medium and temperature

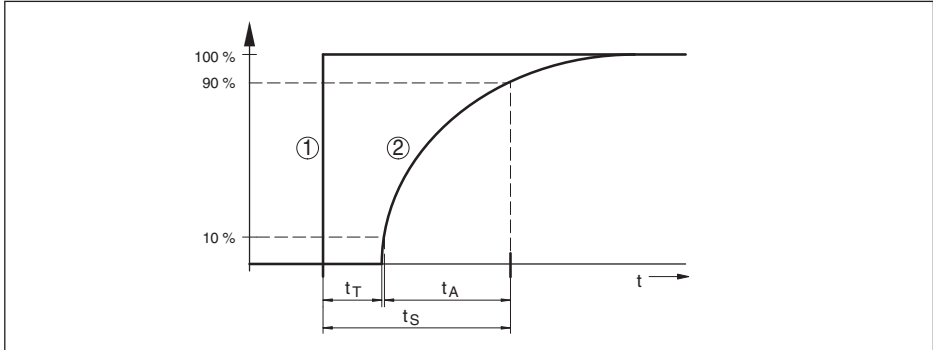

Fig. 25: Behaviour in case of sudden change of the process variable. t_T : dead time; t_A : rise time; t_S : jump response time

- 1 Process variable
- 2 Output signal

Dead time	≤ 50 ms
Rise time	≤ 150 ms
Step response time	≤ 200 ms (t_i : 0 s, 10 ... 90 %)
Damping (63 % of the input variable)	0 ... 999 s, adjustable via menu item "Damping"

Additional output parameter - Measuring cell temperature

Range	-60 ... +150 °C (-76 ... +302 °F)
Resolution	< 0.2 K
Deviation	
- Range of 0 ... +100 °C (+32 ... +212 °F)	± 2 K
- Range of -60 ... 0 °C (-76 ... +32 °F) and +100 ... +150 °C (+212 ... +302 °F)	typ. ± 4 K

Output of the temperature values

- Indication	Via the display and adjustment module
- Analogue	Via the current output, the additional current output
- Digital	Via the digital output signal (depending on the electronics version)

Reference conditions and influencing variables (according to DIN EN 60770-1)

Reference conditions according to DIN EN 61298-1

– Temperature	+15 ... +25 °C (+59 ... +77 °F)
– Relative humidity	45 ... 75 %
– Air pressure	860 ... 1060 mbar/86 ... 106 kPa (12.5 ... 15.4 psig)

Determination of characteristics Limit point adjustment according to IEC 61298-2

Characteristic curve Linear

Reference installation position upright, diaphragm points downward

Influence of the installation position < 0.2 mbar/20 Pa (0.003 psig)

Deviation in the current output due to strong, high-frequency electromagnetic fields acc. to EN 61326-1 < ±150 µA

Deviation (according to IEC 60770-1)

Specifications refer to the set span. Turn down (TD) is the ratio: nominal measuring range/set span.

Accuracy class	Non-linearity, hysteresis and repeatability with TD 1 : 1 up to 5 : 1	Non-linearity, hysteresis and repeatability with 5 : 1
0.1 %	< 0.1 %	< 0.02 % x TD

Influence of the product temperature

Thermal change zero signal and output span

Turn down (TD) is the relation nominal measuring range/adjusted span.

Ceramic/Metal measuring cell - Standard

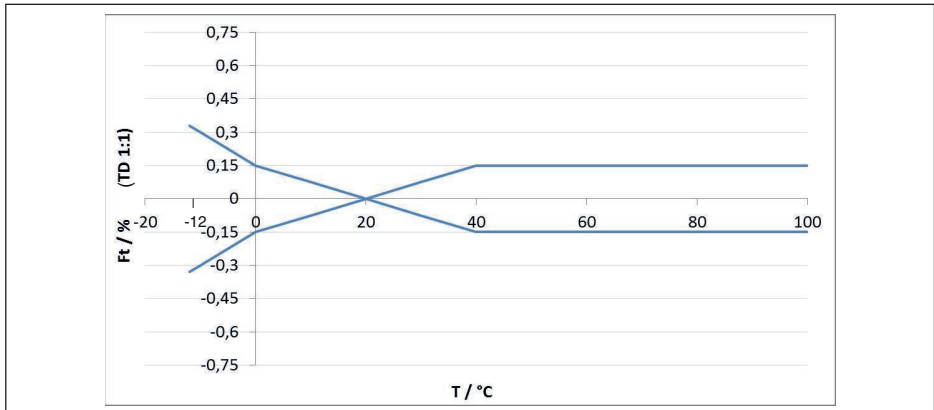

Fig. 26: Basic temperature error $F_{T\text{Basis}}$ at TD 1 : 1

The basic temperature error in % from the above graphic can increase due to the additional factors, depending on the measuring cell version (factor FMZ) and the Turn Down (factor FTD). The additional factors are listed in the following tables.

Additional factor through measuring cell version

Measuring cell version	Measuring cell - Standard	Measuring cell climate-compensated, depending on measuring range		
	0.1 %	10 bar, 25 bar	1 bar, 2.5 bar	0.4 bar
Factor FMZ	1	1	2	3

Additional factor through Turn Down

The additional factor F_{TD} through Turn down is calculated according to the following formula:

$$F_{TD} = 0.5 \times TD + 0.5$$

In the table, example values for typical Turn downs are listed.

Turn Down	TD 1 : 1	TD 2.5 : 1	TD 5 : 1	TD 10 : 1	TD 20 : 1
Factor FTD	1	1.75	3	5.5	10.5

Long-term stability (according to DIN 16086)

Applies to the respective **digital** signal output (e.g. HART, Profibus PA) as well as to **analogue** current output 4 ... 20 mA under reference conditions. Specifications refer to the set span. Turn down (TD) is the ratio nominal measuring range/set span.

Long-term stability zero signal and output span

Time period	All measuring ranges	Measuring range 0 ... +0.025 bar/0 ... +2.5 kPa
One year	< 0.05 % x TD	< 0.1 % x TD
Five years	< 0.1 % x TD	< 0.2 % x TD
Ten years	< 0.2 % x TD	< 0.4 % x TD

Long-term stability zero signal and output span - version climate-compensated

Nominal measuring range in bar/kPa	Nominal measuring range in psig	
0 ... 10 bar/0 ... 1000 kPa	0 ... 150 psig	< (0.1 % x TD)/year
0 ... 25 bar/0 ... 2500 kPa	0 ... 350 psig	
0 ... 1 bar/0 ... 100 kPa	0 ... 15 psig	< (0.25 % x TD)/year
0 ... 2.5 bar/0 ... 250 kPa	0 ... 35 psig	
0 ... 0.4 bar/0 ... 40 kPa	0 ... 6 psig	< (1 % x TD)/year

Ambient conditions

Version	Ambient temperature	Storage and transport temperature
Version with connection tube	-40 ... +80 °C (-40 ... +176 °F)	-60 ... +80 °C (-76 ... +176 °F)
Version with FEP suspension cable	-20 ... +80 °C (-4 ... +176 °F)	-20 ... +80 °C (-4 ... +176 °F)
Version IP68 (1 bar) with connection cable PE	-20 ... +60 °C (-4 ... +140 °F)	-20 ... +60 °C (-4 ... +140 °F)

Process conditions**Process temperature**

Process temperature

- Suspension cable -12 ... +100 °C (+10 ... +212 °F)
- Connection tube -12 ... +100 °C (+10 ... +212 °F)

Process pressurePermissible process pressure see specification " *process pressure* " on the type label**Mechanical stress⁶⁾**

Vibration resistance

- Suspension cable 4 g at 5 ... 200 Hz according to EN 60068-2-6 (vibration with resonance)
- Connection tube 1 g (with lengths > 0.5 m (1.64 ft), the tube must be supported in addition)

Shock resistance

50 g, 2.3 ms according to EN 60068-2-27 (mechanical shock)⁷⁾**Electromechanical data - version IP66/IP67 and IP66/IP68 (0.2 bar)⁸⁾**

Options of the cable entry

- Cable entry M20 x 1.5; ½ NPT
- Cable gland M20 x 1.5; ½ NPT (cable ø see below table)
- Blind plug M20 x 1.5; ½ NPT
- Closing cap ½ NPT

Material cable gland/Seal insert	Cable diameter			
	5 ... 9 mm	6 ... 12 mm	7 ... 12 mm	10 ... 14 mm
PA/NBR	√	√	-	√
Brass, nickel-plated/NBR	√	√	-	-
Stainless steel/NBR	-	-	√	-

Wire cross-section (spring-loaded terminals)

- Massive wire, stranded wire 0.2 ... 2.5 mm² (AWG 24 ... 14)
- Stranded wire with end sleeve 0.2 ... 1.5 mm² (AWG 24 ... 16)

Electromechanical data - version suspension cable IP68 (25 bar)

Suspension cable, mechanical data

- Configuration Wires, strain relief, breather capillaries, screen braiding, metal foil, mantle
- Standard length 5 m (16.40 ft)
- Max. length 250 m (820.2 ft)
- Min. bending radius (at 25 °C/77 °F) 25 mm (0.985 in)
- Diameter approx. 8 mm (0.315 in)

⁶⁾ Depending on the instrument version.⁷⁾ 2 g with housing version stainless steel double chamber.⁸⁾ IP66/IP68 (0.2 bar), only with absolute pressure.

- Colour, suspension cable PE Black, blue
- Colour, suspension cable PUR/FEP Blue

Suspension cable, electrical data

- Wire cross-section 0.5 mm² (AWG 20)
- Wire resistance R' 0.037 Ω/m (0.012 Ω/ft)

Interface to the external display and adjustment unit

- Data transmission Digital (I²C-Bus)
- Connection cable Four-wire

Sensor version	Configuration, connection cable		
	Cable length	Standard cable	Shielded
4 ... 20 mA/HART Modbus	50 m	●	-
Profibus PA, Foundation Fieldbus	25 m	-	●

Interface to the Secondary sensor

- Data transmission Digital (I²C-Bus)
- Configuration, connection cable 4-wire, shielded
- Max. cable length 70 m (229.7 ft)

Integrated clock

- Date format Day.Month.Year
- Time format 12 h/24 h
- Time zone, factory setting CET
- Max. rate deviation 10.5 min/year

Additional output parameter - Electronics temperature

- Range -40 ... +85 °C (-40 ... +185 °F)
- Resolution < 0.1 K
- Deviation ± 3 K
- Availability of the temperature values
 - Indication Via the display and adjustment module
 - Output Via the respective output signal

Voltage supply

- Operating voltage 8 ... 30 V DC
- Max. power consumption 520 mW
- Reverse voltage protection Integrated

Potential connections and electrical separating measures in the instrument

- Electronics Non-floating

Galvanic separation

- between electronics and metallic parts of the device Reference voltage 500 V AC
- between voltage supply and Modbus communication cables Reference voltage 500 V AC

Conductive connection

Between ground terminal and metallic process fitting

Electrical protective measures ⁹⁾

Housing material	Version	Protection acc. to IEC 60529	Protection acc. to NEMA
Plastic	Double chamber	IP66/IP67	Type 4x
Aluminium		IP66/IP68 (0.2 bar)	Type 6P
Stainless steel, precision casting			
Stainless steel (transmitter, version with external housing)		IP68 (25 bar)	-

Connection of the feeding power supply unit Networks of overvoltage category III

Altitude above sea level

- by default up to 2000 m (6562 ft)
- with connected overvoltage protection up to 5000 m (16404 ft)

Pollution degree ¹⁰⁾ 4

Protection rating (IEC 61010-1) II

10.2 Device communication Modbus

In the following, the necessary device-specific details are shown. You can find further information of Modbus on www.modbus.org.

Parameters for the bus communication

The VEGABAR 87 is preset with the following default values:

Parameter	Configurable Values	Default Value
Baud Rate	1200, 2400, 4800, 9600, 19200	9600
Start Bits	1	1
Data Bits	7, 8	8
Parity	None, Odd, Even	None
Stop Bits	1, 2	1
Address range Modbus	1 ... 255	246

Start bits and data bits cannot be modified.

⁹⁾ Protection rating IP66/IP68 (0.2 bar) only in conjunction with absolute pressure, as no air compensation is possible when the sensor is completely flooded

¹⁰⁾ When used with fulfilled housing protection.

General configuration of the host

The data exchange with status and variables between field device and host is carried out via register. For this, a configuration in the host is required. Floating point numbers with short precision (4 bytes) according to IEEE 754 are transmitted with individually selectable order of the data bytes (byte transmission order). This "Byte transmission order" is determined in the parameter "Format Code". Hence the RTU knows the registers of the VEGABAR 87 which must be contacted for the variables and status information.

Format Code	Byte transmission order
0	ABCD
1	CDAB
2	DCBA
3	BADC

10.3 Modbus register

Holding Register

The Holding registers consist of 16 bit. They can be read and written. Before each command, the address (1 byte), after each command, a CRC (2 byte) is sent.

Register Name	Register Number	Type	Configurable Values	Default Value	Unit
Address	200	Word	1 ... 255	246	–
Baud Rate	201	Word	1200, 2400, 4800, 9600, 19200, 38400, 57600	9600	–
Parity	202	Word	0 = None, 1 = Odd, 2 = Even	0	–
Stopbits	203	Word	1 = None, 2 = Two	1	–
Delay Time	206	Word	10 ... 250	50	ms
Byte Oder (Floating point format)	3000	Word	0, 1, 2, 3	0	–

Input register

The input registers consist of 16 bits. They can only be read out. Before each command, the address (1 byte) is sent, after each command a CRC (2 bytes) is sent.

PV, SV, TV and QV can be adjusted via the sensor DTM.

Register Name	Register Number	Type	Note
Status	100	DWord	Bit 0: Invalid Measurement Value PV Bit 1: Invalid Measurement Value SV Bit 2: Invalid Measurement Value TV Bit 3: Invalid Measurement Value QV
PV Unit	104	DWord	Unit Code
PV	106		Primary Variable in Byte Order CDAB
SV Unit	108	DWord	Unit Code

Register Name	Register Number	Type	Note
SV	110		Secondary Variable in Byte Order CDAB
TV Unit	112	DWord	Unit Code
TV	114		Third Variable in Byte Order CDAB
QV Unit	116	DWord	Unit Code
QV	118		Quarternary Variable in Byte Order CDAB
Status	1300	DWord	See Register 100
PV	1302		Primary Variable in Byte Order of Register 3000
SV	1304		Secondary Variable in Byte Order of Register 3000
TV	1306		Third Variable in Byte Order of Register 3000
QV	1308		Quarternary Variable in Byte Order of Register 3000
Status	1400	DWord	See Register 100
PV	1402		Primary Variable in Byte Order CDAB
Status	1412	DWord	See Register 100
SV	1414		Secondary Variable in Byte Order CDAB
Status	1424	DWord	See Register 100
TV	1426		Third Variable in Byte Order CDAB
Status	1436	DWord	See Register 100
QV	1438		Quarternary Variable in Byte Order CDAB
Status	2000	DWord	See Register 100
PV	2002	DWord	Primary Variable in Byte Order ABCD (Big Endian)
SV	2004	DWord	Secondary Variable in Byte Order ABCD (Big Endian)
TV	2006	DWord	Third Variable in Byte Order ABCD (Big Endian)
QV	2008	DWord	Quarternary Variable in Byte Order ABCD (Big Endian)
Status	2100	DWord	See Register 100
PV	2102	DWord	Primary Variable in Byte Order DCBA (Little Endian)
SV	2104	DWord	Secondary Variable in Byte Order DCBA (Little Endian)
TV	2106	DWord	Third Variable in Byte Order ABCD DCBA (Little Endian)
QV	2108	DWord	Quarternary Variable in Byte Order DCBA (Little Endian)
Status	2200	DWord	See Register 100
PV	2202	DWord	Primary Variable in Byte Order BACD (Middle Endian)
SV	2204	DWord	Secondary Variable in Byte Order BACD (Middle Endian)
TV	2206	DWord	Third Variable in Byte Order BACD (Middle Endian)
QV	2208	DWord	Quarternary Variable in Byte Order BACD (Middle Endian)

Unit Codes for Register 104, 108, 112, 116

Unit Code	Measurement Unit
1	in H2O
2	in Hg
3	ft H2O
4	mm H2O
5	mm Hg
6	psi
7	bar
8	mbar
11	Pa
12	kPa
13	torr
32	°C
33	°F
40	US liq. gal.
41	L
42	Imp. Gal.
43	m3
44	ft
45	m
46	bbl
47	in
48	cm
49	mm
111	cyd
112	cft
113	cuin
237	MPa

10.4 Modbus RTU commands

FC3 Read Holding Register

With this command, any number (1-127) of holding registers is read out. The start register, from which the readout should start, and the number of registers are transmitted.

	Parameter	Length	Code/Data
Request:	Function Code	1 Byte	0x03
	Start Address	2 Bytes	0x0000 to 0xFFFF
	Number of Registers	2 Bytes	1 to 127 (0x7D)

	Parameter	Length	Code/Data
Response:	Function Code	1 Byte	0x03
	Byte Count	2 Bytes	2*N
	Register Value	N*2 Bytes	Data

FC4 Read Input Register

With this command, any number (1-127) of input registers is read out. The start register, from which the readout should start, and the number of registers are transmitted.

	Parameter	Length	Code/Data
Request:	Function Code	1 Byte	0x04
	Start Address	2 Bytes	0x0000 to 0xFFFF
	Number of Registers	N*2 Bytes	1 to 127 (0x7D)
Response:	Function Code	1 Byte	0x04
	Byte Count	2 Bytes	2*N
	Register Value	N*2 Bytes	Data

FC6 Write Single Register

This function code is used to write to a single Holding Register.

	Parameter	Length	Code/Data
Request:	Function Code	1 Byte	0x06
	Start Address	2 Bytes	0x0000 to 0xFFFF
	Number of Registers	2 Bytes	Data
Response:	Function Code	1 Byte	0x04
	Start Address	2 Bytes	2*N
	Register Value	2 Bytes	Data

FC8 Diagnostics

With this function code different diagnostic functions are triggered or diagnostic values read out.

	Parameter	Length	Code/Data
Request:	Function Code	1 Byte	0x08
	Sub Function Code	2 Bytes	
	Data	N*2 Bytes	Data
Response:	Function Code	1 Byte	0x08
	Sub Function Code	2 Bytes	
	Data	N*2 Bytes	Data

Implemented function codes:

Sub Function Code	Name
0x00	Return Data Request
0x0B	Return Message Counter

With sub function codes 0x00 only one 16 bit value can be written.

FC16 Write Multiple Register

This function code is used to write to several Holding Registers. In a request, it can only be written to registers that are in direct succession.

	Parameter	Length	Code/Data
Request:	Function Code	1 Byte	0x10
	Start Address	2 Bytes	0x0000 to 0xFFFF
	Number of Registers	2 Bytes	0x0001 to 0x007B
	Byte Count	1 Byte	2*N
	Register Value	N*2 Bytes	Data
Response:	Function Code	1 Byte	0x10
	Start Address	2 Bytes	0x0000 to 0xFFFF
	Number of Registers	2 Bytes	0x01 to 0x7B

FC17 Report Sensor ID

With this function code, the sensor ID on Modbus is queried.

	Parameter	Length	Code/Data
Request:	Function Code	1 Byte	0x11
Response:	Function Code	1 Byte	0x11
	Byte Number	1 Byte	
	Sensor ID	1 Byte	
	Run Indicator Status	1 Byte	

FC43 Sub 14, Read Device Identification

With this function code, the Device Identification is queried.

	Parameter	Length	Code/Data
Request:	Function Code	1 Byte	0x2B
	MEI Type	1 Byte	0x0E
	Read Device ID Code	1 Byte	0x01 to 0x04
	Object ID	1 Byte	0x00 to 0xFF

	Parameter	Length	Code/Data
Response:	Function Code	1 Byte	0x2B
	MEI Type	1 Byte	0x0E
	Read Device ID Code	1 Byte	0x01 to 0x04
	Confirmity Level	1 Byte	0x01, 0x02, 0x03, 0x81, 0x82, 0x83
	More follows	1 Byte	00/FF
	Next Object ID	1 Byte	Object ID number
	Number of Objects	1 Byte	
	List of Object ID	1 Byte	
	List of Object length	1 Byte	
	List of Object value	1 Byte	Depending on the Object ID

10.5 Levelmaster commands

The VEGABAR 87 is also suitable for connection to the following RTUs with Levelmaster protocol. The Levelmaster protocol is often called "*Siemens*" "*Tank protocol*".

RTU	Protocol
ABB Totalflow	Levelmaster
Kimray DACC 2000/3000	Levelmaster
Thermo Electron Autopilot	Levelmaster

Parameters for the bus communication

The VEGABAR 87 is preset with the default values:

Parameter	Configurable Values	Default Value
Baud Rate	1200, 2400, 4800, 9600, 19200	9600
Start Bits	1	1
Data Bits	7, 8	8
Parity	None, Odd, Even	None
Stop Bits	1, 2	1
Address range Levelmaster	32	32

The Levelmaster commands are based on the following syntax:

- Capital letters are at the beginning of certain data fields
- Small letters stand for data fields
- All commands are terminated with "*<cr>*" (carriage return)
- All commands start with "*Uuu*", whereby "*uu*" stands for the address (00-31)
- "*''*" can be used as a joker for any position in the address. The sensor always converts this in its address. In case of more than one sensor, the joker must not be used, because otherwise several slaves will answer
- Commands that modify the instrument return the command with "*OK*". "*EE-ERROR*" replaces "*OK*" if there was a problem changing the configuration

Report Level (and Temperature)

	Parameter	Length	Code/Data
Request:	Report Level (and Temperature)	4 characters ASCII	Uuu?
Response:	Report Level (and Temperature)	24 characters ASCII	UuuDIII.IIFttEeeeeWwww uu = Address III.II = PV in inches tt = Temperature in Fahrenheit eeee = Error number (0 no error, 1 level data not readable) www = Warning number (0 no warning)

PV in inches will be repeated if "Set number of floats" is set to 2. Hence 2 measured values can be transmitted. PV value is transmitted as first measured value, SV as second measured value.



Information:

The max. value for the PV to be transmitted is 999.99 inches (corresponds to approx. 25.4 m).

If the temperature should be transmitted in the Levelmaster protocol, then TV must be set in the sensor to temperature.

PV, SV and TV can be adjusted via the sensor DTM.

Report Unit Number

	Parameter	Length	Code/Data
Request:	Report Unit Number	5 characters ASCII	U**N?
Response:	Report Level (and Temperature)	6 characters ASCII	UuuNnn

Assign Unit Number

	Parameter	Length	Code/Data
Request:	Assign Unit Number	6 characters ASCII	UuuNnn
Response:	Assign Unit Number	6 characters ASCII	UuuNOK uu = new Address

Set number of Floats

	Parameter	Length	Code/Data
Request:	Set number of Floats	5 characters ASCII	UuuFn
Response:	Set number of Floats	6 characters ASCII	UuuFOK

If the number is set to 0, no level is returned

Set Baud Rate

	Parameter	Length	Code/Data
Request:	Set Baud Rate	8 (12) characters ASCII	UuuBbbbb[b][pds] Bbbbb[b] = 1200, 9600 (default) pds = parity, data length, stop bit (optional) parity: none = N, even = E (default), odd = O
Response:	Set Baud Rate	11 characters ASCII	

Example: U01B9600E71

Change instrument on address 1 to baudrate 9600, parity even, 7 data bits, 1 stop bit

Set Receive to Transmit Delay

	Parameter	Length	Code/Data
Request:	Set Receive to Transmit Delay	7 characters ASCII	UuuRmmm mmm = milliseconds (50 up to 250), default = 127 ms
Response:	Set Receive to Transmit Delay	6 characters ASCII	UuuROK

Report Number of Floats

	Parameter	Length	Code/Data
Request:	Report Number of Floats	4 characters ASCII	UuuF
Response:	Report Number of Floats	5 characters ASCII	UuuFn n = number of measurement values (0, 1 or 2)

Report Receive to Transmit Delay

	Parameter	Length	Code/Data
Request:	Report Receive to Transmit Delay	4 characters ASCII	UuuR
Response:	Report Receive to Transmit Delay	7 characters ASCII	UuuRmmm mmm = milliseconds (50 up to 250), default = 127 ms

Error codes

Error Code	Name
EE-Error	Error While Storing Data in EEPROM
FR-Error	Error in Frame (too short, too long, wrong data)
LV-Error	Value out of limits

10.6 Configuration of typical Modbus hosts

Fisher ROC 809

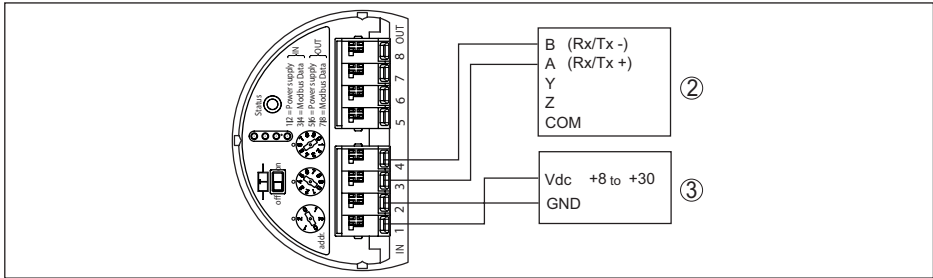

Fig. 27: Connection of VEGABAR 87 to RTU Fisher ROC 809

- 1 VEGABAR 87
- 2 RTU Fisher ROC 809
- 3 Voltage supply

Parameters for Modbus Hosts

Parameter	Value Fisher ROC 809	Value ABB Total Flow	Value Fisher Thermo Electron Autopilot	Value Fisher Bristol Control-Wave Micro	Value Scada-Pack
Baud Rate	9600	9600	9600	9600	9600
Floating Point Format Code	0	0	0	2 (FC4)	0
RTU Data Type	Conversion Code 66	16 Bit Modicon	IEE Fit 2R	32-bit registers as 2 16-bit registers	Floating Point
Input Register Base Number	0	1	0	1	30001

The basic number of the input registers is always added to the input register address of VEGABAR 87.

This results in the following constellations:

- Fisher ROC 809 - Register address for 1300 is address 1300
- ABB Total Flow - Register address for 1302 is address 1303
- Thermo Electron Autopilot - Register address for 1300 is address 1300
- Bristol ControlWave Micro - Register address for 1302 is address 1303
- ScadaPack - Register address for 1302 is address 31303

10.7 Calculation of the total deviation

The total deviation of a pressure transmitter indicates the maximum measurement error to be expected in practice. It is also called maximum practical deviation or operational error.

According to DIN 16086, the total deviation F_{total} is the sum of the basic deviation F_{perf} and the long-term stability F_{stab} :

$$F_{total} = F_{perf} + F_{stab}$$

The basic deviation F_{perf} in turn consists of the thermal change of the zero signal and the output span F_T (temperature error) as well as the deviation F_{Kl} :

$$F_{\text{perf}} = \sqrt{((F_T)^2 + (F_{\text{KI}})^2)}$$

The thermal change of zero signal and output span F_T is specified in chapter " *Technical data*". The basic temperature error F_T is shown in a graphic. Depending on the measuring cell version and Turn down, this value must be multiplied with the additional factors FMZ and FTD:

$$F_T \times \text{FMZ} \times \text{FTD}$$

Also these values are specified in chapter " *Technical data*".

This applies initially to the digital signal output through HART, Profibus PA, Foundation Fieldbus or Modbus.

With 4 ... 20 mA output, the thermal change of the current output F_a must be added:

$$F_{\text{perf}} = \sqrt{((F_T)^2 + (F_{\text{KI}})^2 + (F_a)^2)}$$

To provide a better overview, the formula symbols are listed together below:

- F_{total} : Total deviation
- F_{perf} : Basic deviation
- F_{stab} : Long-term stability
- F_T : Thermal change of zero signal and output span (temperature error)
- F_{KI} : Deviation
- F_a : Thermal change of the current output
- FMZ: Additional factor measuring cell version
- FTD: Additional factor Turn down

10.8 Practical example

Data

Level measurement in a water reservoir, 1,600 mm height corresponds to 0.157 bar (157 kPa), medium temperature 50 °C

VEGABAR 87 with measuring range 0.4 bar, deviation < 0.1 %, meas. cell ø 28 mm

1. Calculation of the Turn down

TD = 0.4 bar/0.157 bar, TD = **2.6 : 1**

2. Determination temperature error F_T

The necessary values are taken from the technical data:

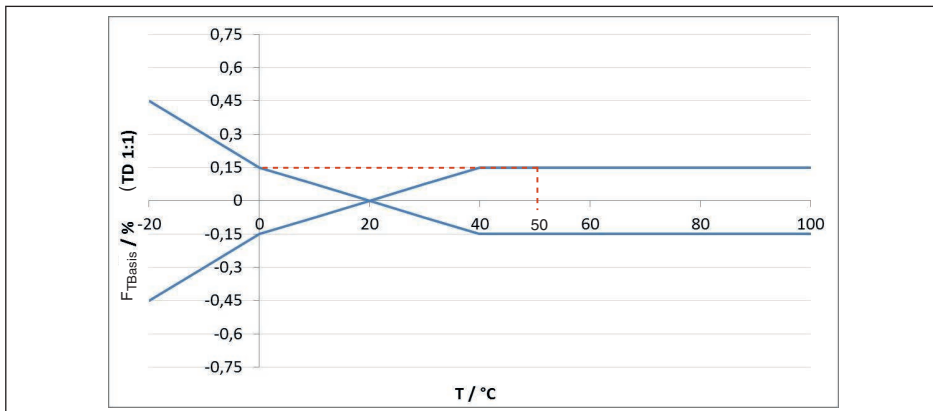

Fig. 28: Determination of the basic temperature error for the above example: $F_{\text{TBasis}} = \mathbf{0.15\%}$

Turn Down	TD 1 : 1	TD 2.5 : 1	TD 5 : 1	TD 10 : 1	TD 20 : 1
Factor F _{TD}	1	1.75	3	5.5	10.5

Tab. 47: Determination of the additional factor "turn down" for the above example: $F_{TD} = 1.75$

Turn Down	TD 1 : 1	TD 2.5 : 1	TD 5 : 1	TD 10 : 1	TD 20 : 1
Factor F _{TD}	1	1.75	3	5.5	10.5

Tab. 48: Determination of the additional factor "turn down" for the above example: $F_{TD} = 1.75$

$$F_T = F_{TBasis} \times F_{MZ} \times F_{TD}$$

$$F_T = 0.15 \% \times 1 \times 1.75$$

$$F_T = 0.26 \%$$

3. Determination of deviation and long-term stability

The required values for deviation F_{KI} and long-term stability F_{stab} are available in the technical data:

Accuracy class	Non-linearity, hysteresis and non-repeatability	
	TD ≤ 5 : 1	TD > 5 : 1
0.1 %	< 0.1 %	< 0.02 % x TD

Tab. 49: Determination of the deviation from table: $F_{KI} = 0.1 \%$

VEGABAR 86

Time period	Measuring cell ø 28 mm		Measuring cell ø 17.5 mm
	All measuring ranges	Measuring range 0 ... +0.025 bar/0 ... +2.5 kPa	
One year	< 0.05 % x TD	< 0.1 % x TD	< 0.1 % x TD
Five years	< 0.1 % x TD	< 0.2 % x TD	< 0.2 % x TD
Ten years	< 0.2 % x TD	< 0.4 % x TD	< 0.4 % x TD

VEGABAR 87

Time period	All measuring ranges	Measuring range 0 ... +0.025 bar/0 ... +2.5 kPa
One year	< 0.05 % x TD	< 0.1 % x TD
Five years	< 0.1 % x TD	< 0.2 % x TD
Ten years	< 0.2 % x TD	< 0.4 % x TD

Tab. 50: Determination of the long-term stability from the table, consideration for one year: $F_{stab} = 0.05 \% \times TD = 0.05 \% \times 2.6 = 0.13 \%$

4. Calculation of the total deviation - digital signal

- 1. step: Basic accuracy F_{perf}

$$F_{perf} = \sqrt{((F_T)^2 + (F_{KI})^2)}$$

$$F_T = 0.26 \%$$

$$F_{KI} = 0.1 \%$$

$$F_{\text{perf}} = \sqrt{(0.26\%)^2 + (0.1\%)^2}$$

$$F_{\text{perf}} = 0.28\%$$

- 2. step: Total deviation F_{total}

$$F_{\text{total}} = F_{\text{perf}} + F_{\text{stab}}$$

$$F_{\text{perf}} = 0.28\% \text{ (result of step 1)}$$

$$F_{\text{stab}} = (0.05\% \times \text{TD})$$

$$F_{\text{stab}} = (0.05\% \times 2.5)$$

$$F_{\text{stab}} = 0.13\%$$

$$F_{\text{total}} = 0.28\% + 0.13\% = 0.41\%$$

The total deviation of the measuring system is hence 0.41 %.

Deviation in mm: 0.41 % of 1600 mm = 7 mm

The example shows that the measurement error in practice can be considerably higher than the basic accuracy. Reasons are temperature influence and Turn down.

10.9 Dimensions

The following dimensional drawings represent only an extract of the possible versions. Detailed dimensional drawings can be downloaded at www.vega.com under "Downloads" and "Drawings".

Plastic housing

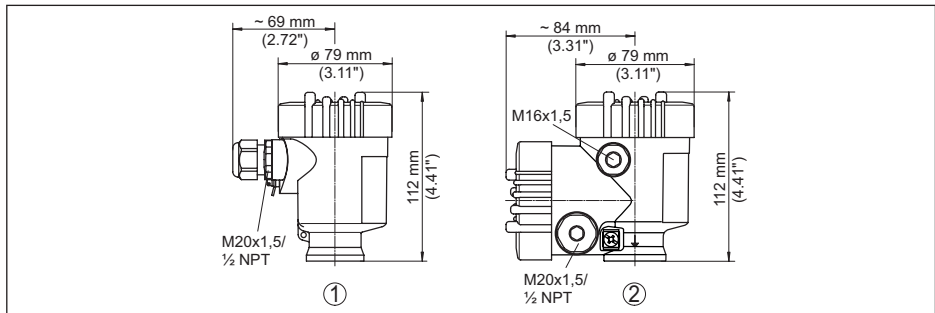

Fig. 29: Housing versions in protection IP66/IP67 (with integrated display and adjustment module the housing is 9 mm/0.35 in higher)

- 1 Plastic single chamber
- 2 Plastic double chamber

Aluminium housing

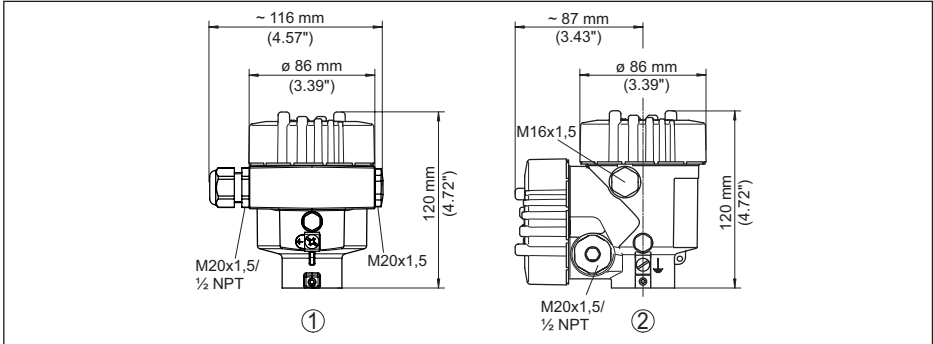

Fig. 30: Housing versions with protection rating IP66/IP68 (0.2 bar), (with integrated display and adjustment module the housing is 18 mm/0.71 in higher)

- 1 Aluminium - single chamber
- 2 Aluminium - double chamber

Aluminium housing with protection rating IP66/IP68 (1 bar)

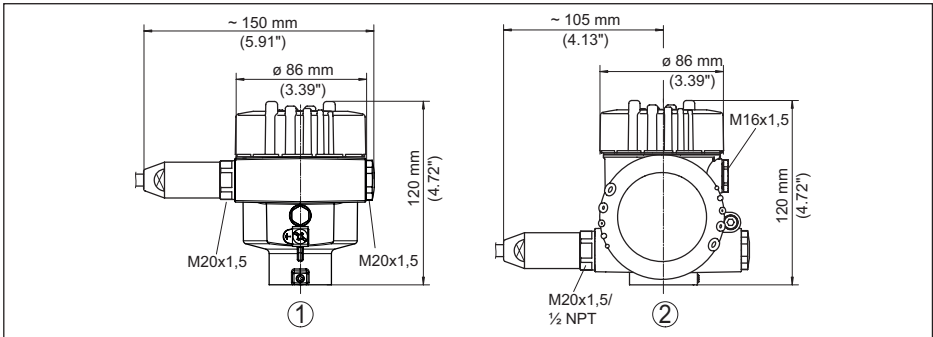

Fig. 31: Housing version with protection rating IP66/IP68 (1 bar), (with integrated display and adjustment module the housing is 18 mm/0.71 in higher)

- 1 Aluminium - single chamber
- 2 Aluminium - double chamber

Stainless steel housing

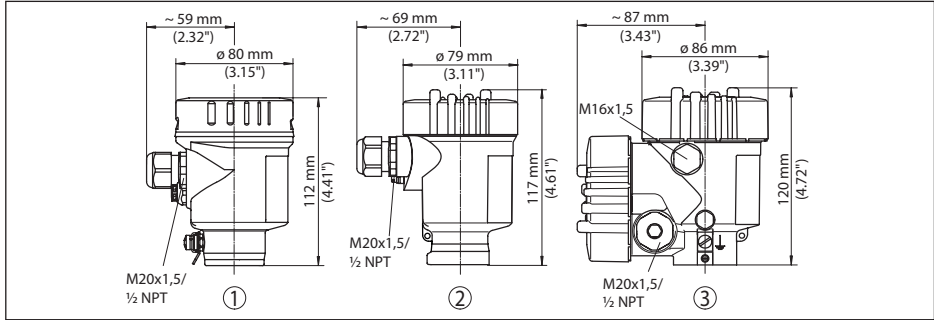

Fig. 32: Housing versions in protection rating IP66/IP68 (0.2 bar), (with integrated display and adjustment module the housing is 9 mm/0.35 in or 18 mm/0.71 in higher)

- 1 Stainless steel single chamber (electropolished)
- 2 Stainless steel single chamber (precision casting)
- 2 Stainless steel double chamber (precision casting)

Stainless steel housing with protection rating IP66/IP68 (1 bar)

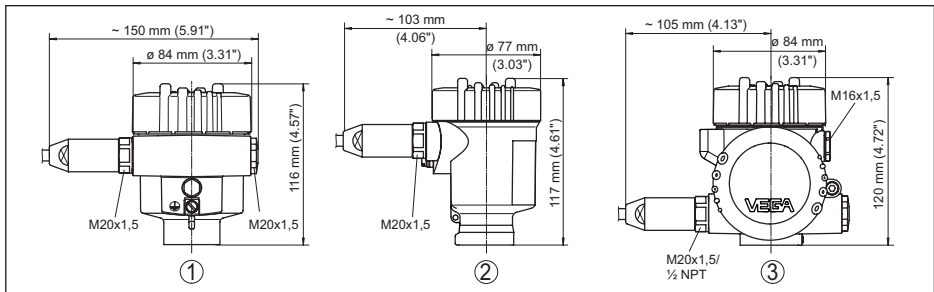

Fig. 33: Housing versions in protection rating IP66/IP68 (1 bar), (with integrated display and adjustment module the housing is 9 mm/0.35 in or 18 mm/0.71 in higher)

- 1 Stainless steel single chamber (electropolished)
- 2 Stainless steel single chamber (precision casting)
- 3 Stainless steel double chamber (precision casting)

Stainless steel housing with protection rating IP69K

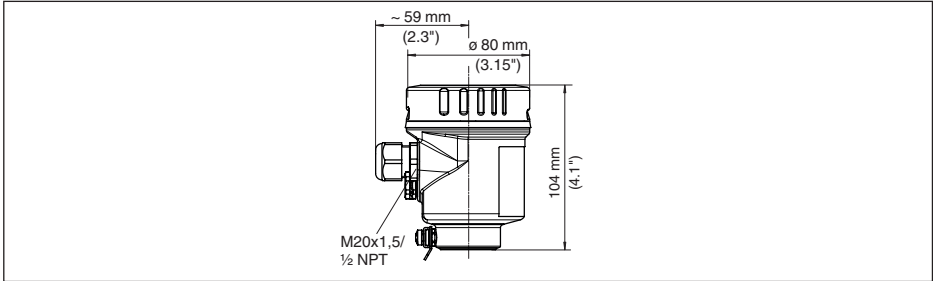

Fig. 34: Housing version with protection rating IP69K (with integrated display and adjustment module the housing is 9 mm/0.35 in higher)

- 1 *Stainless steel single chamber (electropolished)*

External housing on IP68 version

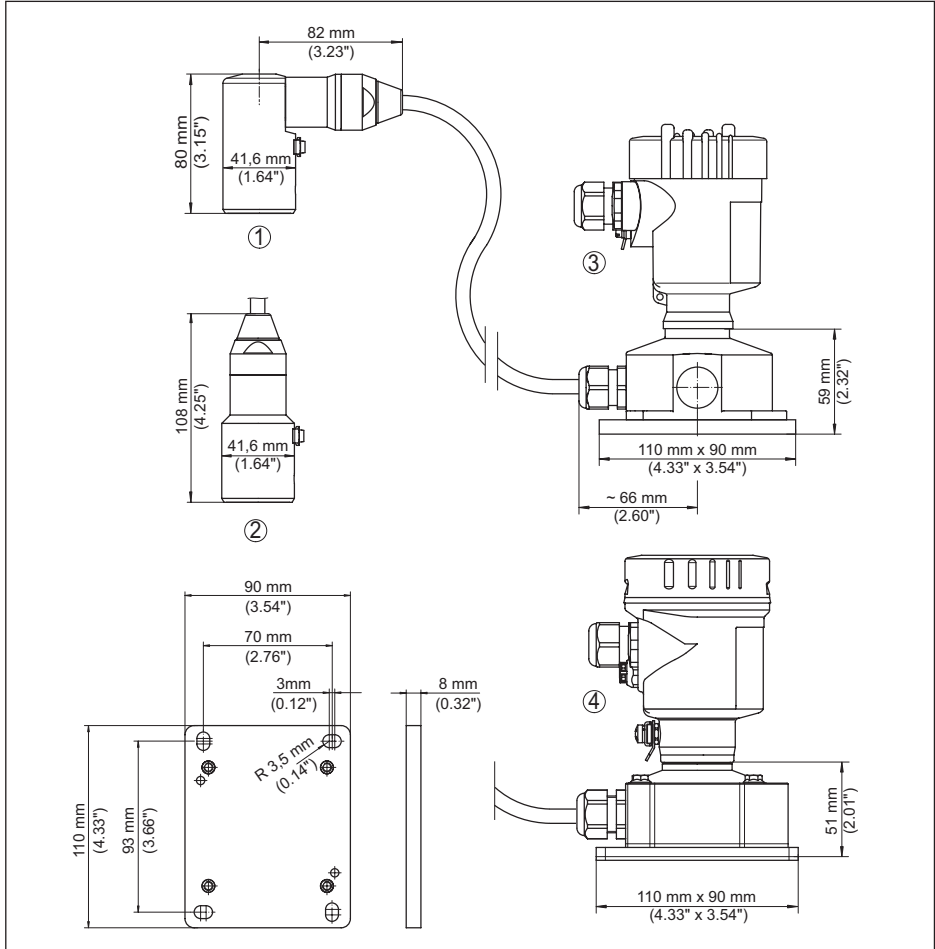

Fig. 35: VEGABAR 87, IP68 version with external housing

- 1 Lateral cable outlet
- 2 Axial cable outlet
- 3 Plastic single chamber
- 4 Stainless steel single chamber
- 5 Seal 2 mm (0.079 in), (only with 3A approval)

VEGABAR 87

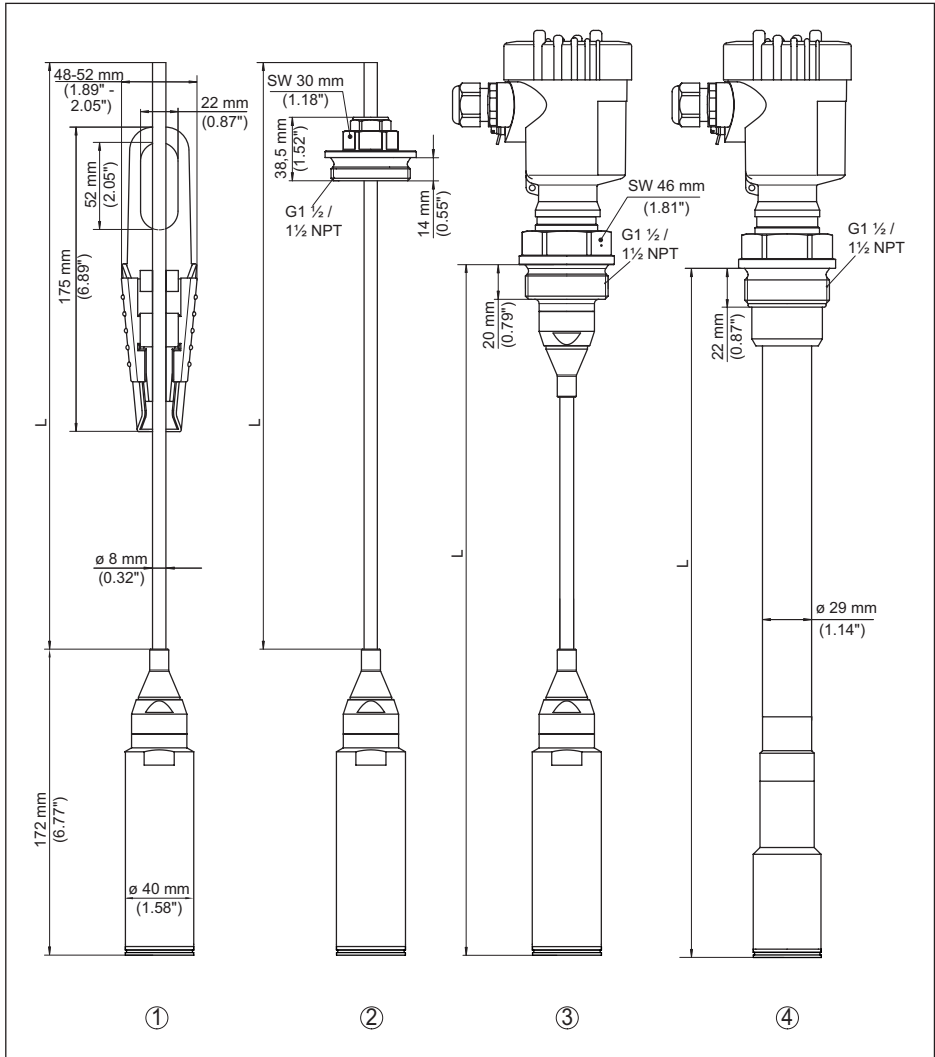

Fig. 36: VEGABAR 87, standard fittings

- 1 Straining clamp
- 2 Threaded fitting
- 3 Thread G1 1/2
- 4 Thread 1 1/2 NPT

L Total length from configurator

VEGABAR 87, flange connection

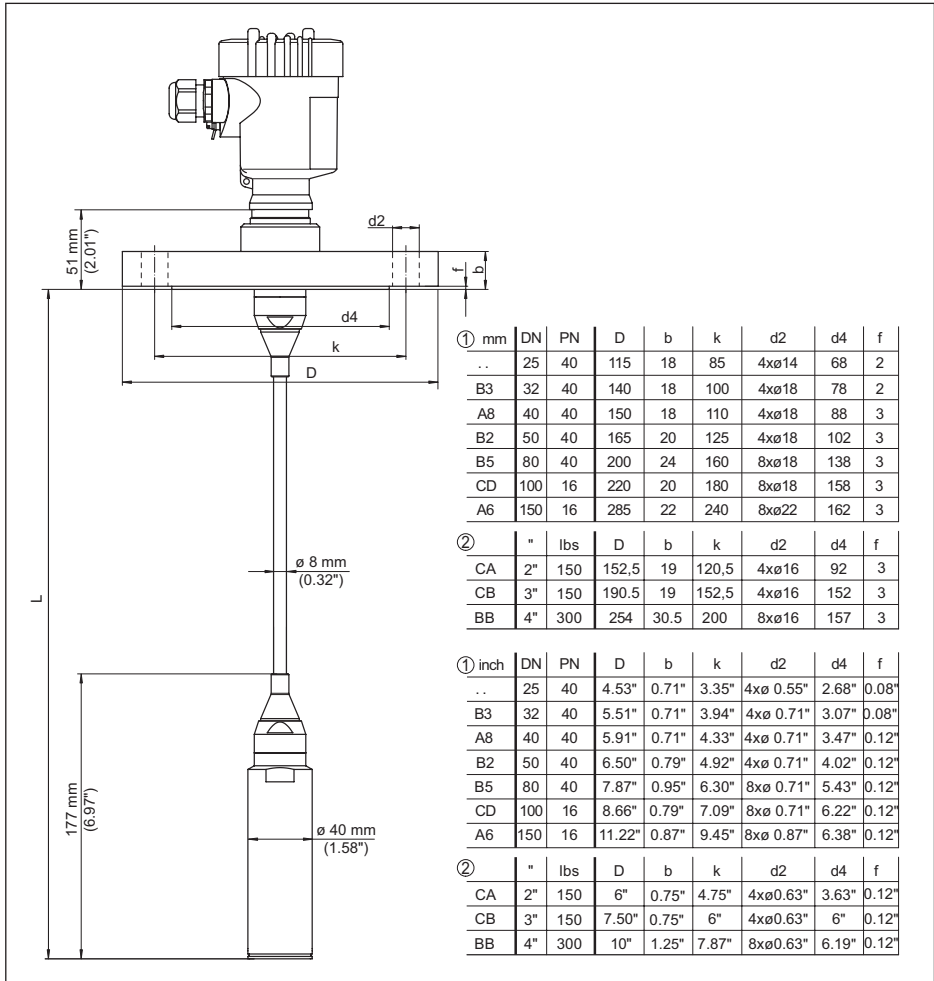

Fig. 37: VEGABAR 87, flange connection

- 1 Flanges according to DIN 2501
 2 Flanges according to ASME B16.5
 L Total length from configurator

VEGABAR 87, hygienic fitting

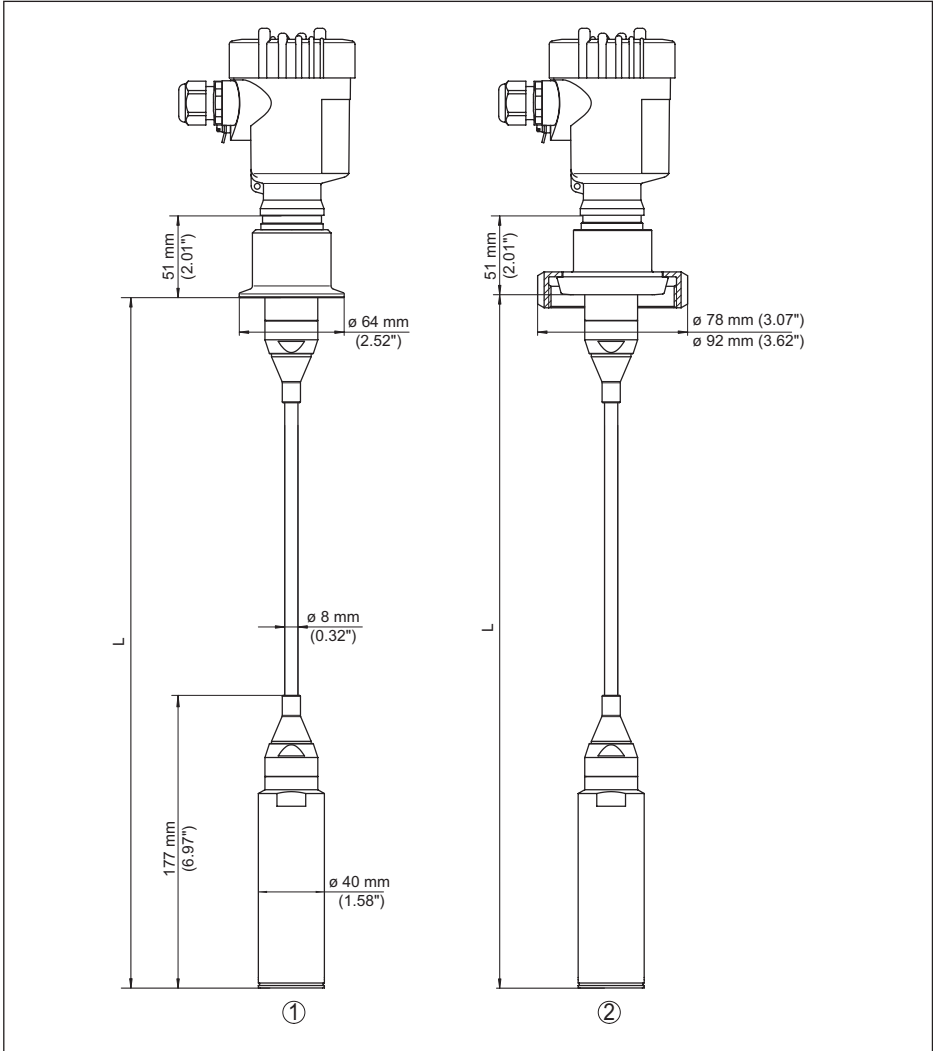

Fig. 38: VEGABAR 87, hygienic fittings

- 1 Clamp 2" PN 16 (ø 64 mm), (DIN 32676, ISO 2852)
- 2 Slotted nut DN 50
- L Total length from configurator

10.10 Industrial property rights

VEGA product lines are global protected by industrial property rights. Further information see www.vega.com.

VEGA Produktfamilien sind weltweit geschützt durch gewerbliche Schutzrechte.

Nähere Informationen unter www.vega.com.

Les lignes de produits VEGA sont globalement protégées par des droits de propriété intellectuelle. Pour plus d'informations, on pourra se référer au site www.vega.com.

VEGA lineas de productos están protegidas por los derechos en el campo de la propiedad industrial. Para mayor información revise la pagina web www.vega.com.

Линии продукции фирмы ВЕГА защищаются по всему миру правами на интеллектуальную собственность. Дальнейшую информацию смотрите на сайте www.vega.com.

VEGA系列产品在全球享有知识产权保护。

进一步信息请参见网站 < www.vega.com。

10.11 Trademark

All the brands as well as trade and company names used are property of their lawful proprietor/originator.

INDEX**A**

- Adjust Date/Time 33
- Adjustment 26, 29, 30
 - Overview 28
 - Unit 28

C

- Change the language 31
- Connection procedure 17
- Connection technology 17
- Copy sensor settings 34

D

- Damping 30
- Display lighting 32
- Documentation 7

E

- Electronics compartment 19
- Error codes 44, 45

F

- Fault rectification 46
- Functional principle 8

L

- Level measurement 15
- Linearisation 30

M

- Maintenance 42
- Measured value memory 42
- Measurement setup
 - In the open vessel 15

N

- NAMUR NE 107 43

P

- Peak indicator 33
- Position correction 28
- Pressure compensation 15

Q

- QR code 7

R

- Repair 48
- Reset 34

S

- Seal concept 9
- Serial number 7
- Service access 35
- Service hotline 46
- Set display parameters 32
- Simulation 33

T

- Type label 7

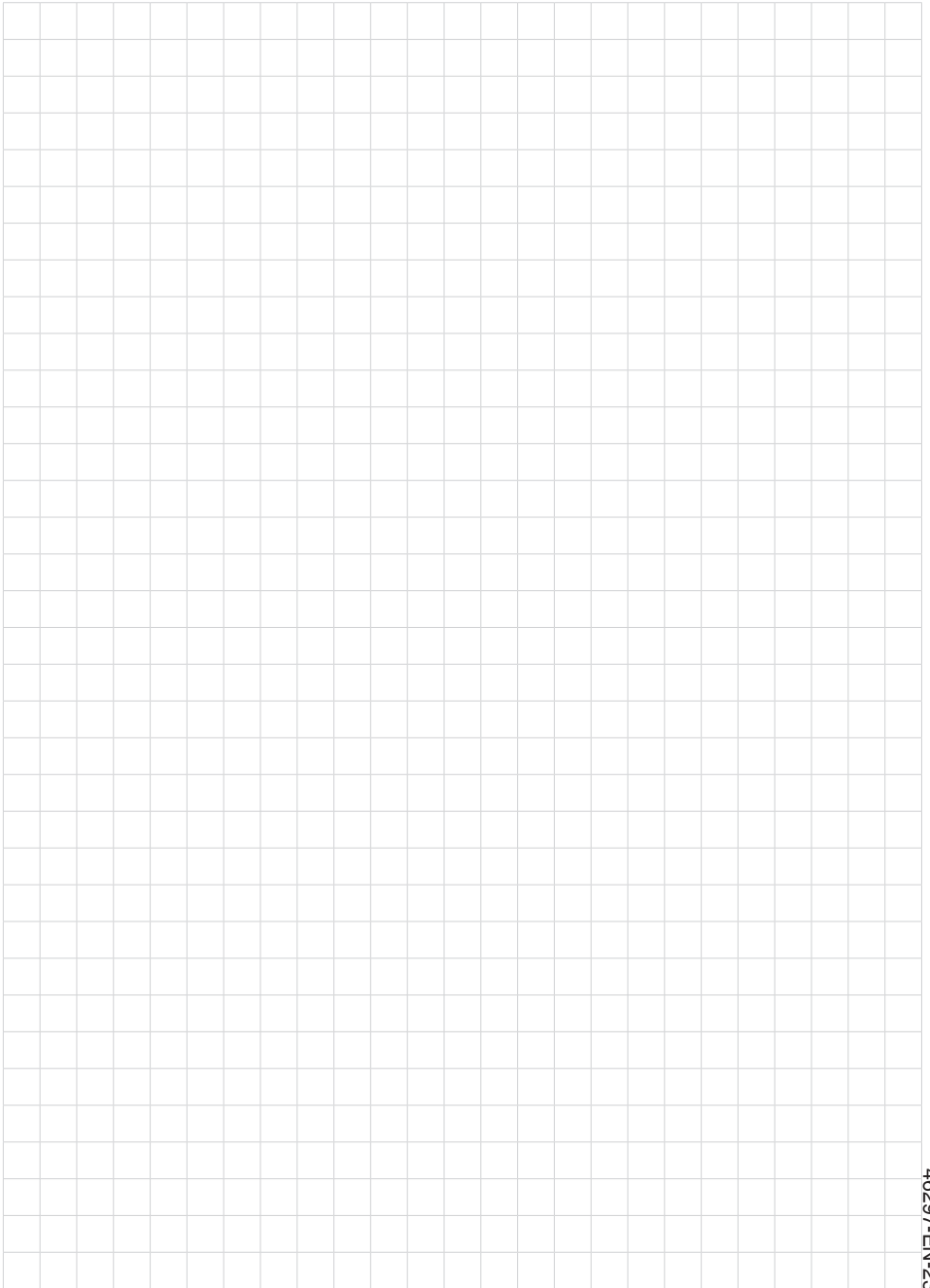

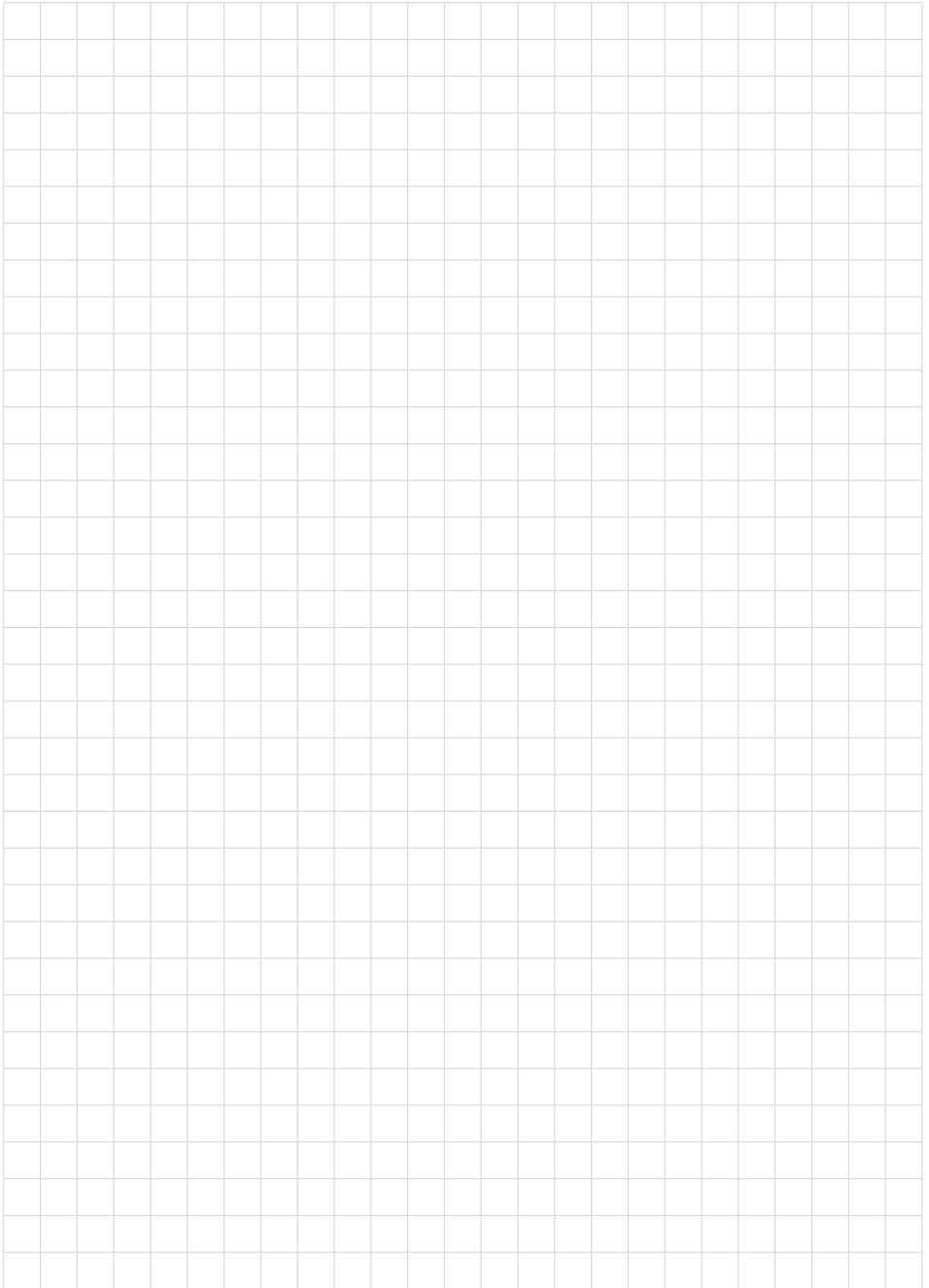

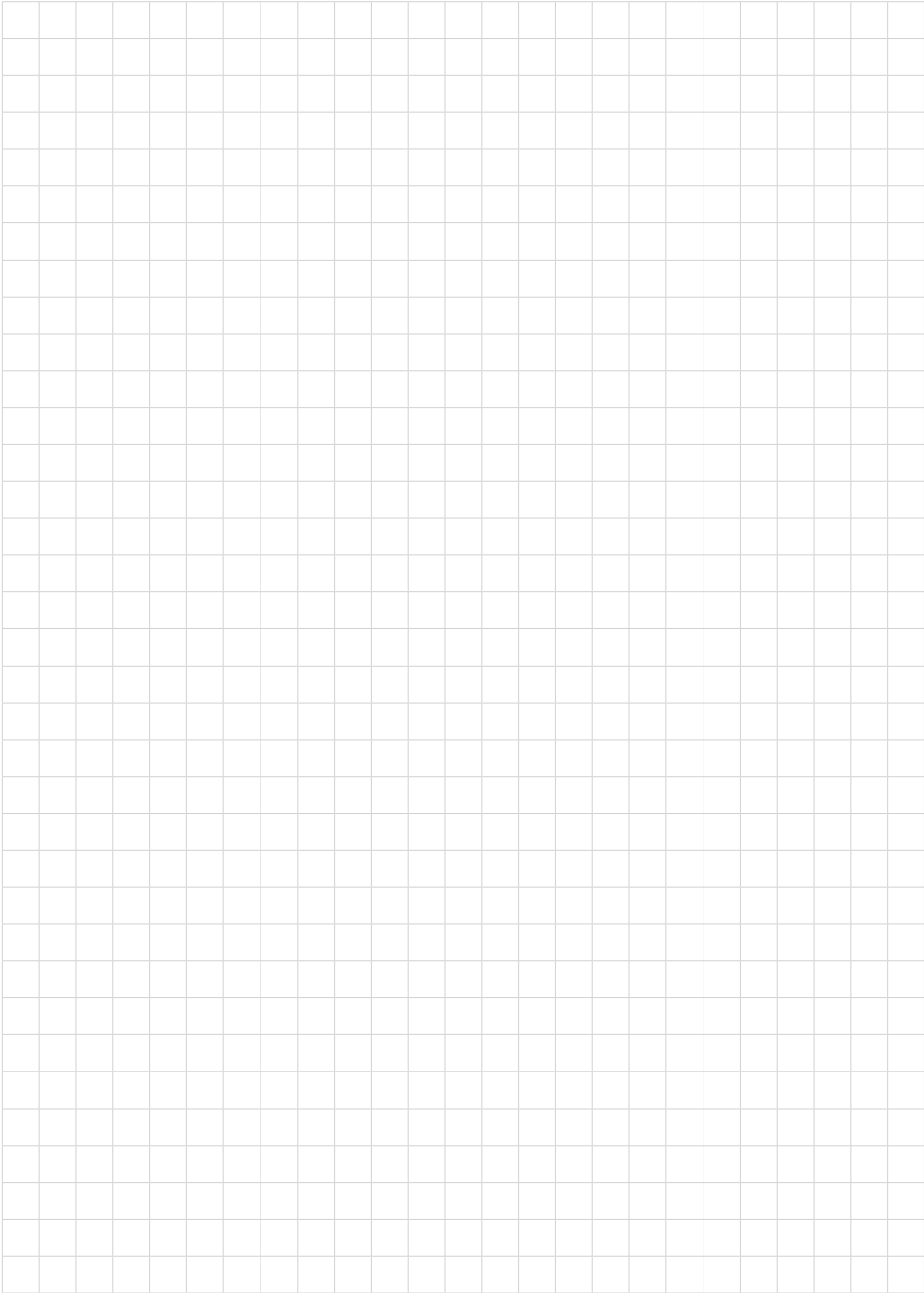

Printing date:

VEGA

All statements concerning scope of delivery, application, practical use and operating conditions of the sensors and processing systems correspond to the information available at the time of printing.

Subject to change without prior notice

© VEGA Grieshaber KG, Schiltach/Germany 2023



46297-EN-230914

VEGA Grieshaber KG
Am Hohenstein 113
77761 Schiltach
Germany

Phone +49 7836 50-0
E-mail: info.de@vega.com
www.vega.com