

Operating Instructions

Supplementary electronics

For Foundation Fieldbus



Document ID: 45111



VEGA

Contents

1	About this document	3
1.1	Function	3
1.2	Target group	3
1.3	Symbols used.....	3
2	For your safety	4
2.1	Authorised personnel	4
2.2	Appropriate use.....	4
2.3	Approvals	4
2.4	Environmental instructions	4
3	Product description	5
3.1	Configuration.....	5
3.2	Principle of operation.....	5
3.3	Packaging, transport and storage.....	5
4	Mounting	7
4.1	Installation procedure	7
5	Maintenance	8
5.1	How to proceed if a repair is necessary	8
6	Dismount	9
6.1	Dismounting steps.....	9
6.2	Disposal	9
7	Supplement	10
7.1	Technical data	10

1 About this document

1.1 Function

This operating instructions manual provides all the information you need for mounting, connection and setup as well as important instructions for maintenance, fault rectification, the exchange of parts and the safety of the user. Please read this information before putting the instrument into operation and keep this manual accessible in the immediate vicinity of the device.

1.2 Target group

This operating instructions manual is directed to trained personnel. The contents of this manual must be made available to the qualified personnel and implemented.

1.3 Symbols used



Document ID

This symbol on the front page of this instruction refers to the Document ID. By entering the Document ID on www.vega.com you will reach the document download.



Information, tip, note

This symbol indicates helpful additional information.



Caution: If this warning is ignored, faults or malfunctions can result.
Warning: If this warning is ignored, injury to persons and/or serious damage to the instrument can result.



Danger: If this warning is ignored, serious injury to persons and/or destruction of the instrument can result.



Ex applications

This symbol indicates special instructions for Ex applications.



List

The dot set in front indicates a list with no implied sequence.



Action

This arrow indicates a single action.



Sequence of actions

Numbers set in front indicate successive steps in a procedure.



Battery disposal

This symbol indicates special information about the disposal of batteries and accumulators.

2 For your safety

2.1 Authorised personnel

All operations described in this documentation must be carried out only by trained specialist personnel authorised by the plant operator. During work on and with the device the required personal protective equipment must always be worn.

2.2 Appropriate use

The components described in this manual are replacement components for existing sensors.

2.3 Approvals

If the instrument comes with approvals, the associated approval documents of the sensor must always be noted. They are included with the delivery but can also be downloaded under "www.vega.com", "*Instrument search*" as well as via "*Downloads*" and "*Approvals*".

2.4 Environmental instructions

Protection of the environment is one of our most important duties. That is why we have introduced an environment management system with the goal of continuously improving company environmental protection. The environment management system is certified according to DIN EN ISO 14001.

Please help us fulfil this obligation by observing the environmental instructions in this manual:

- Chapter "*Packaging, transport and storage*"
- Chapter "*Disposal*"

3 Product description

3.1 Configuration

Scope of delivery

The scope of delivery encompasses:

- Supplementary electronics for Foundation Fieldbus
- Documentation
 - This operating instructions manual
 - If necessary, further certificates

3.2 Principle of operation

Application area

The supplementary electronics Foundation Fieldbus is a replacement component for sensors with signal output Foundation Fieldbus and double chamber housing.

- VEGAPULS series 60
 - Hardware version from 2.0.0
 - Software version from 4.0.0
- VEGAFLEX 80 series
- VEGABAR series 80
- VEGADIF 85

Functional principle

The supplementary electronics for Foundation Fieldbus is used for connection of a sensor with double chamber housing to Foundation Fieldbus systems.

3.3 Packaging, transport and storage

Packaging

Your instrument was protected by packaging during transport. Its capacity to handle normal loads during transport is assured by a test based on ISO 4180.

The packaging of standard instruments consists of environment-friendly, recyclable cardboard. For special versions, PE foam or PE foil is also used. Dispose of the packaging material via specialised recycling companies.

Transport

Transport must be carried out in due consideration of the notes on the transport packaging. Nonobservance of these instructions can cause damage to the device.

Transport inspection

The delivery must be checked for completeness and possible transit damage immediately at receipt. Ascertained transit damage or concealed defects must be appropriately dealt with.

Storage

Up to the time of installation, the packages must be left closed and stored according to the orientation and storage markings on the outside.

Unless otherwise indicated, the packages must be stored only under the following conditions:

- Not in the open
- Dry and dust free
- Not exposed to corrosive media

Storage and transport temperature

- Protected against solar radiation
- Avoiding mechanical shock and vibration
- Storage and transport temperature see chapter "*Supplement - Technical data - Ambient conditions*"
- Relative humidity 20 ... 85 %

Lifting and carrying

With instrument weights of more than 18 kg (39.68 lbs) suitable and approved equipment must be used for lifting and carrying.

4 Mounting

4.1 Installation procedure

Installation procedure

The supplementary electronics is mounted in the power supply compartment. The following illustration shows the position of the power supply compartment in the double chamber housing.

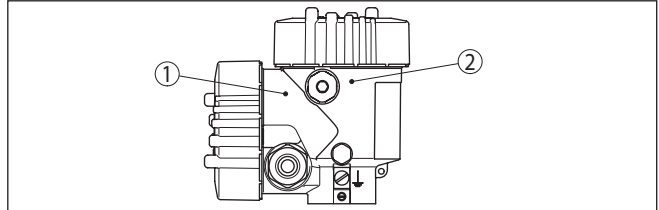

Fig. 1: Position of the power supply and electronics compartment

- 1 Supply room (supplementary electronics)
- 2 Electronics compartment (sensor electronics)

Proceed as follows:

1. Unscrew housing cover of the power supply compartment
2. Loosen the two holding screws of the supplementary electronics with a screwdriver (Torx size T 10 or slot size 4)

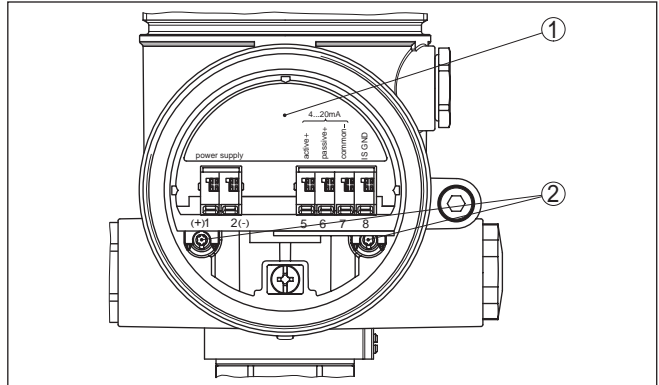

Fig. 2: Power supply compartment with supplementary electronics

- 1 Supplementary electronics
- 2 Screws (2 pcs.)
3. Pull the previous supplementary electronics out by using the dismantling tool.
4. Insert the new supplementary electronics module carefully.
5. Screw in the two holding screws and tighten them
6. Screw the housing lid back on

The supplementary electronics is exchanged.



As a rule, the exchange of the supplementary electronics must be documented internally when used in Ex applications.

5 Maintenance

5.1 How to proceed if a repair is necessary

You can find an instrument return form as well as detailed information about the procedure in the download area of our homepage: www.vega.com. By doing this you help us carry out the repair quickly and without having to call back for needed information.

In case of repair, proceed as follows:

- Print and fill out one form per instrument
- Clean the instrument and pack it damage-proof
- Attach the completed form and, if need be, also a safety data sheet outside on the packaging
- Ask the agency serving you to get the address for the return shipment. You can find the agency on our home page www.vega.com.

6 Dismount

6.1 Dismounting steps

**Warning:**

Before dismantling, be aware of dangerous process conditions such as e.g. pressure in the vessel or pipeline, high temperatures, corrosive or toxic products etc.

Take note of chapters "*Mounting*" and "*Connecting to power supply*" and carry out the listed steps in reverse order.

6.2 Disposal

The instrument consists of materials which can be recycled by specialised recycling companies. We use recyclable materials and have designed the electronics to be easily separable.

Correct disposal avoids negative effects on humans and the environment and ensures recycling of useful raw materials.

Materials: see chapter "*Technical data*"

If you have no way to dispose of the old instrument properly, please contact us concerning return and disposal.

WEEE directive 2012/19/EU

This instrument is not subject to the WEEE directive 2012/19/EU and the respective national laws. Pass the instrument directly on to a specialised recycling company and do not use the municipal collecting points. These may be used only for privately used products according to the WEEE directive.

7 Supplement

7.1 Technical data

Technical data

The technical data are listed in the operating instructions manual of the respective sensor.



Printing date:

VEGA

All statements concerning scope of delivery, application, practical use and operating conditions of the sensors and processing systems correspond to the information available at the time of printing.

Subject to change without prior notice

© VEGA Grieshaber KG, Schiltach/Germany 2018



45111-EN-180712

VEGA Grieshaber KG
Am Hohenstein 113
77761 Schiltach
Germany

Phone +49 7836 50-0
Fax +49 7836 50-201
E-mail: info.de@vega.com
www.vega.com