

Operating Instructions

Pressure transmitter with ceramic measuring cell

VEGABAR 86

Secondary Device for electronic differential pressure



Document ID: 45052



VEGA

Contents

1	About this document	4
1.1	Function	4
1.2	Target group	4
1.3	Symbols used	4
2	For your safety	5
2.1	Authorised personnel	5
2.2	Appropriate use	5
2.3	Warning about incorrect use	5
2.4	General safety instructions	5
2.5	Conformity	5
2.6	NAMUR recommendations	6
2.7	Installation and operation in the USA and Canada	6
2.8	Environmental instructions	6
3	Product description	7
3.1	Configuration	7
3.2	Principle of operation	7
3.3	Packaging, transport and storage	9
3.4	Accessories	10
4	Mounting	11
4.1	General instructions	11
4.2	Ventilation and pressure compensation	13
4.3	Combination Primary - Secondary	15
4.4	Differential pressure measurement	16
4.5	Interface measurement	16
4.6	Density measurement	17
4.7	Density-compensated level measurement	18
4.8	External housing	20
5	Connecting to power supply	21
5.1	Preparing the connection	21
5.2	Connecting	22
5.3	Single chamber housing	23
5.4	External housing with version IP68 (25 bar)	24
5.5	Connection example	26
6	Set up with the display and adjustment module	27
6.1	Parameter adjustment - Extended adjustment	27
6.2	Menu overview	39
7	Diagnosis, asset management and service	42
7.1	Maintenance	42
7.2	Rectify faults	42
7.3	Exchanging the electronics module	42
7.4	Exchange process module on version IP68 (25 bar)	43
7.5	How to proceed if a repair is necessary	44
8	Dismount	45
8.1	Dismounting steps	45
8.2	Disposal	45
9	Supplement	46

9.1	Technical data	46
9.2	Calculation of the total deviation.....	54
9.3	Practical example.....	55
9.4	Dimensions	57
9.5	Industrial property rights.....	66
9.6	Trademark	66



Safety instructions for Ex areas:

Take note of the Ex specific safety instructions for Ex applications. These instructions are attached as documents to each instrument with Ex approval and are part of the operating instructions.

Editing status: 2023-09-01

1 About this document

1.1 Function

This instruction provides all the information you need for mounting, connection and setup as well as important instructions for maintenance, fault rectification, safety and the exchange of parts. Please read this information before putting the instrument into operation and keep this manual accessible in the immediate vicinity of the device.

1.2 Target group

This operating instructions manual is directed to trained personnel. The contents of this manual must be made available to the qualified personnel and implemented.

1.3 Symbols used



Document ID

This symbol on the front page of this instruction refers to the Document ID. By entering the Document ID on www.vega.com you will reach the document download.



Information, note, tip: This symbol indicates helpful additional information and tips for successful work.



Note: This symbol indicates notes to prevent failures, malfunctions, damage to devices or plants.



Caution: Non-observance of the information marked with this symbol may result in personal injury.



Warning: Non-observance of the information marked with this symbol may result in serious or fatal personal injury.



Danger: Non-observance of the information marked with this symbol results in serious or fatal personal injury.



Ex applications

This symbol indicates special instructions for Ex applications.



List

The dot set in front indicates a list with no implied sequence.



Sequence of actions

Numbers set in front indicate successive steps in a procedure.



Disposal

This symbol indicates special instructions for disposal.

2 For your safety

2.1 Authorised personnel

All operations described in this documentation must be carried out only by trained and authorized personnel.

During work on and with the device, the required personal protective equipment must always be worn.

2.2 Appropriate use

As Secondary Device, the VEGABAR 86 is part of an electronic differential pressure measurement.

You can find detailed information about the area of application in chapter " *Product description*".

Operational reliability is ensured only if the instrument is properly used according to the specifications in the operating instructions manual as well as possible supplementary instructions.

2.3 Warning about incorrect use

Inappropriate or incorrect use of this product can give rise to application-specific hazards, e.g. vessel overfill through incorrect mounting or adjustment. Damage to property and persons or environmental contamination can result. Also, the protective characteristics of the instrument can be impaired.

2.4 General safety instructions

This is a state-of-the-art instrument complying with all prevailing regulations and directives. The instrument must only be operated in a technically flawless and reliable condition. The operating company is responsible for the trouble-free operation of the instrument. When measuring aggressive or corrosive media that can cause a dangerous situation if the instrument malfunctions, the operating company has to implement suitable measures to make sure the instrument is functioning properly.

The safety instructions in this operating instructions manual, the national installation standards as well as the valid safety regulations and accident prevention rules must be observed.

For safety and warranty reasons, any invasive work on the device beyond that described in the operating instructions manual may be carried out only by personnel authorised by us. Arbitrary conversions or modifications are explicitly forbidden. For safety reasons, only the accessory specified by us must be used.

To avoid any danger, the safety approval markings and safety tips on the device must also be observed.

2.5 Conformity

The device complies with the legal requirements of the applicable country-specific directives or technical regulations. We confirm conformity with the corresponding labelling.

The corresponding conformity declarations can be found on our homepage.

2.6 NAMUR recommendations

As a Secondary Device, the device is part of an electronic differential pressure measurement. It fulfils the requirements of the NAMUR recommendations of the respective Primary Devices.

2.7 Installation and operation in the USA and Canada

This information is only valid for USA and Canada. Hence the following text is only available in the English language.

Installations in the US shall comply with the relevant requirements of the National Electrical Code (NEC - NFPA 70) (USA).

Installations in Canada shall comply with the relevant requirements of the Canadian Electrical Code (CEC Part) (Canada).

2.8 Environmental instructions

Protection of the environment is one of our most important duties. That is why we have introduced an environment management system with the goal of continuously improving company environmental protection. The environment management system is certified according to DIN EN ISO 14001.

Please help us fulfil this obligation by observing the environmental instructions in this manual:

- Chapter "*Packaging, transport and storage*"
- Chapter "*Disposal*"

3 Product description

3.1 Configuration

Scope of delivery

The scope of delivery encompasses:

- Pressure transmitter VEGABAR 86 - Secondary Device
- Ready-made connection cable, unassembled cable gland

The further scope of delivery encompasses:

- Documentation
 - Quick setup guide
 - Test certificate for pressure transmitters
 - Instructions for optional instrument features
 - Ex-specific "*Safety instructions*" (with Ex versions)
 - If necessary, further certificates



Information:

Optional instrument features are also described in this operating instructions manual. The respective scope of delivery results from the order specification.

Type label

The type label contains the most important data for identification and use of the instrument:

- Instrument type
- Information about approvals
- Configuration information
- Technical data
- Serial number of the instrument
- QR code for device identification
- Numerical code for Bluetooth access (optional)
- Manufacturer information

Documents and software

To find order data, documents or software related to your device, you have the following options:

- Move to "www.vega.com" and enter in the search field the serial number of your instrument.
- Scan the QR code on the type label.
- Open the VEGA Tools app and enter the serial number under "**Documentation**".

3.2 Principle of operation

Application area

The VEGABAR 86 is a submersible pressure transmitter for level measurement in wells, basins and open vessels. Its great flexibility through different cable and tube versions allows the instrument to be used in many different applications.

Measured products

Measured products are liquids.

Depending on the instrument version and measurement setup, measured products can also be viscous or contain abrasive substances.

Measured variables

The differential pressure measurement is suitable for the measurement of the following process variables:

- Level
- Flow
- Differential pressure
- Density
- Interface

Electronic differential pressure

The VEGABAR 86 Secondary Device is combined with a sensor from the VEGABAR 80 series for electronic differential pressure measurement.

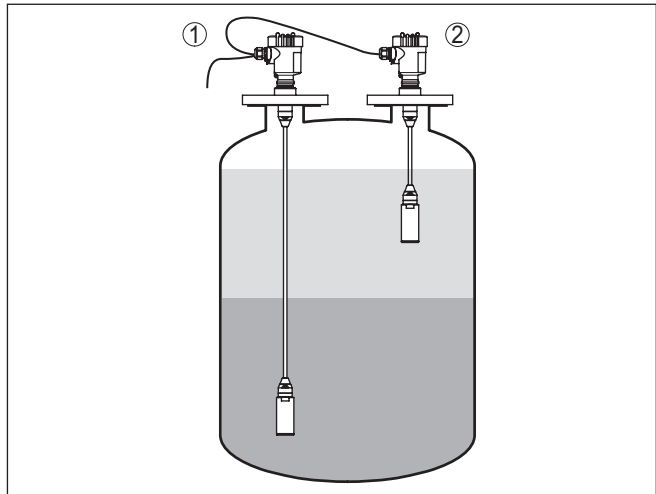

Fig. 1: Example, electronic differential pressure for interface measurement

1 VEGABAR 86

2 VEGABAR 86 - Secondary Device

The sensors are connected via a shielded four-wire cable. The measured value from the Secondary Device is read in and factored into the calculations. Power supply and parameter adjustment are carried out through the Primary Device.

**Information:**

The sensor versions "Relative pressure climate-compensated" as well as "Double chamber housing" are not suitable for connection of a Secondary Device.

You can find further information in chapter "Combination Primary - Secondary" of this operating instructions.

Measuring system

The sensor element is the CERTEC® measuring cell with robust ceramic diaphragm. The process pressure deflects the ceramic diaphragm and causes a capacitance change in the measuring cell. This capacitance change is converted into an electrical signal and outputted as measured value via the output signal.

The measuring cell is available in two sizes:

- CERTEC® (ø 28 mm) with transmitter ø 32 mm
- Mini-CERTEC® (ø 17.5 mm) with transmitter ø 22 mm

Measuring system temperature

A temperature sensor in the ceramic diaphragm of the CERTEC® or on the ceramic base of the Mini-CERTEC® measuring cell detects the actual process temperature. The temperature value is output via:

- The display and adjustment module

Extreme process temperature jumps are also immediately detected by the ø 28 mm measuring cell. The values are compared with that of an additional temperature measurement on the ceramic base body.

Within only a few measuring cycles the intelligent sensor electronics compensates unavoidable measurement deviations due to temperature shocks. Such shocks cause (depending on the set damping) only slight, brief changes to the output signal.

Pressure types

Relative pressure: the measuring cell is open to the atmosphere. The ambient pressure is detected in the measuring cell and compensated. It thus has no influence on the measured value.

Absolute pressure: the measuring cell contains vacuum and is encapsulated. The ambient pressure is not compensated and does hence influence the measured value.

Seal concept

The following illustration shows the installation of the ceramic measuring cell in the sensor as well as the sealing concept.

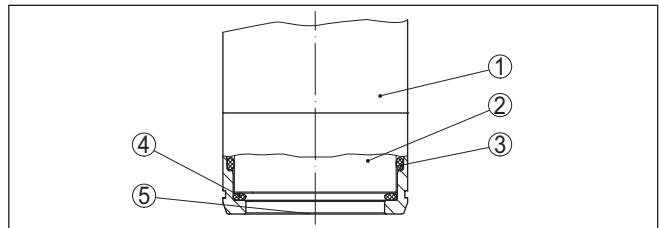

Fig. 2: Front-flush installation of the ceramic measuring cell with double seal

- 1 Housing, sensor
- 2 Measuring cell
- 3 Lateral seal for measuring cell
- 4 Additional, front seal for measuring cell
- 5 Diaphragm

3.3 Packaging, transport and storage

Packaging

Your instrument was protected by packaging during transport. Its capacity to handle normal loads during transport is assured by a test based on ISO 4180.

The packaging consists of environment-friendly, recyclable cardboard. For special versions, PE foam or PE foil is also used. Dispose of the packaging material via specialised recycling companies.

Transport	Transport must be carried out in due consideration of the notes on the transport packaging. Nonobservance of these instructions can cause damage to the device.
Transport inspection	The delivery must be checked for completeness and possible transit damage immediately at receipt. Ascertained transit damage or concealed defects must be appropriately dealt with.
Storage	<p>Up to the time of installation, the packages must be left closed and stored according to the orientation and storage markings on the outside.</p> <p>Unless otherwise indicated, the packages must be stored only under the following conditions:</p> <ul style="list-style-type: none"> ● Not in the open ● Dry and dust free ● Not exposed to corrosive media ● Protected against solar radiation ● Avoiding mechanical shock and vibration
Storage and transport temperature	<ul style="list-style-type: none"> ● Storage and transport temperature see chapter " <i>Supplement - Technical data - Ambient conditions</i>" ● Relative moisture 20 ... 85 %
Lifting and carrying	With instrument weights of more than 18 kg (39.68 lbs) suitable and approved equipment must be used for lifting and carrying.
3.4 Accessories	
The instructions for the listed accessories can be found in the download area on our homepage.	
Protective cover	The protective cover protects the sensor housing against soiling and intense heat from solar radiation.
Flanges	Screwed flanges are available in different versions according to the following standards: DIN 2501, EN 1092-1, BS 10, ASME B 16.5, JIS B 2210-1984, GOST 12821-80.
Welded socket, threaded and hygienic adapter	<p>Welded sockets are used to connect the devices to the process.</p> <p>Threaded and hygienic adapters enable simple adaptation of devices with standard threaded fittings to process-side hygiene connections.</p>

4 Mounting

4.1 General instructions

Process conditions



Note:

For safety reasons, the instrument must only be operated within the permissible process conditions. You can find detailed information on the process conditions in chapter " *Technical data*" of the operating instructions or on the type label.

Hence make sure before mounting that all parts of the instrument exposed to the process are suitable for the existing process conditions.

These are mainly:

- Active measuring component
- Process fitting
- Process seal

Process conditions in particular are:

- Process pressure
- Process temperature
- Chemical properties of the medium
- Abrasion and mechanical influences

Protection against moisture

Protect your instrument against moisture ingress through the following measures:

- Use a suitable connection cable (see chapter " *Connecting to power supply*")
- Tighten the cable gland or plug connector
- Lead the connection cable downward in front of the cable entry or plug connector

This applies mainly to outdoor installations, in areas where high humidity is expected (e.g. through cleaning processes) and on cooled or heated vessels.



Note:

Make sure that during installation or maintenance no moisture or dirt can get inside the instrument.

To maintain the housing protection, make sure that the housing lid is closed during operation and locked, if necessary.

Screwing in

Devices with threaded fitting are screwed into the process fitting with a suitable wrench via the hexagon.

See chapter " *Dimensions*" for wrench size.



Warning:

The housing or the electrical connection may not be used for screwing in! Depending on the device version, tightening can cause damage, e. g. to the rotation mechanism of the housing.

Vibrations

Avoid damages on the device by lateral forces, for example by vibrations. It is thus recommended to fix the devices with process fitting

thread G $\frac{1}{2}$ of plastic at the installation site via a suitable measuring instrument holder.

If there is strong vibration at the mounting location, the instrument version with external housing should be used. See chapter " *External housing*".

Permissible process pressure (MWP) - Device

The permissible process pressure range is specified on the type label with "MWP" (Maximum Working Pressure), see chapter " *Configuration*". This applies even if a measuring cell with a measuring range (order-related) higher than the permissible pressure range of the process fitting is installed.

In addition, a temperature derating of the process fitting, e. g. with flanges, can limit the permissible process pressure range according to the respective standard.

Permissible process pressure (MWP) - Mounting accessory

The permissible process pressure range is stated on the type label. The instrument should only be operated with these pressures if the mounting accessory used also fulfils these values. This should be ensured by suitable flanges, welded sockets, tension rings with Clamp connections, sealings, etc.

Temperature limits

Higher process temperatures often mean also higher ambient temperatures. Make sure that the upper temperature limits stated in chapter " *Technical data*" for the environment of the electronics housing and connection cable are not exceeded.

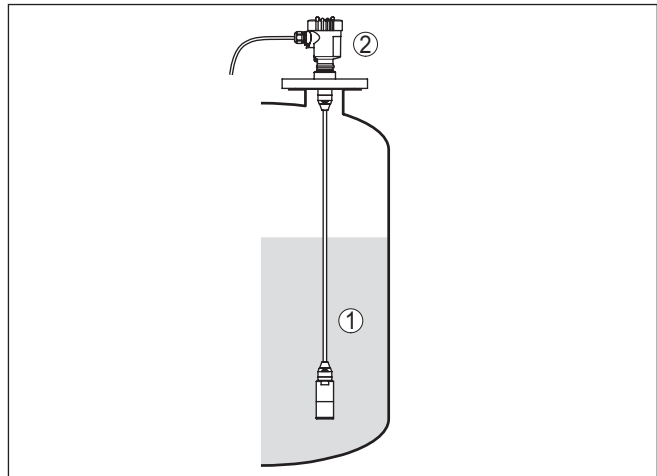

Fig. 3: Temperature ranges

- 1 Process temperature
- 2 Ambient temperature

Transport and mounting protection

Depending on the transmitter, the VEGABAR 86 is supplied with a protective cap or a transport and mounting protection.

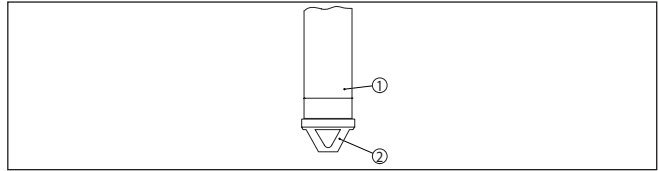

Fig. 4: VEGABAR 86, transport and mounting protection

- 1 Transmitter
2 Transport and mounting protection

Remove this protection after mounting and before setting up the instrument.

In case of slightly contaminated measured media, the transport and mounting protection can remain on the instrument as an impact protection during operation.

4.2 Ventilation and pressure compensation

Filter element - Function

The filter element in the electronics housing has the following functions:

- Ventilation of the electronics housing
- Atmospheric pressure compensation (with relative pressure measuring ranges)



Caution:

The filter element causes a time-delayed pressure compensation. When quickly opening/closing the housing cover, the measured value can change for approx. 5 s by up to 15 mbar.

For an effective ventilation, the filter element must be always free from buildup. In case of horizontal mounting, turn the housing so that the filter element points downward after the instrument is installed. This provides better protection against buildup.



Caution:

Do not use a high-pressure cleaner. The filter element could be damaged, which would allow moisture into the housing.

The following paragraphs describe how the filter element is arranged in the different instrument versions.

Filter element - Position

Fig. 5: Position of the filter element - non-Ex, Ex ia version

- 1 Plastic, stainless steel housing (precision casting)
- 2 Aluminium housing
- 3 Stainless steel housing (electropolished)
- 4 Filter element

With the following instruments a blind plug is installed instead of the filter element:

- Instruments in protection IP66/IP68 (1 bar) - ventilation via capillaries in non-detachable cable
- Instruments with absolute pressure

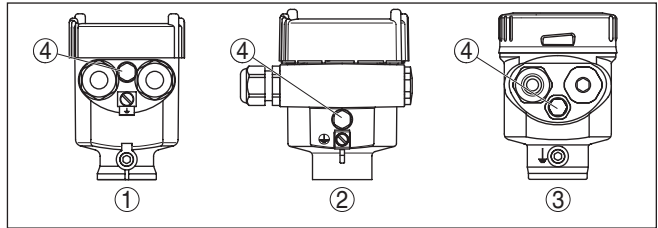
Instruments with Second Line of Defense

The process assembly of instruments with Second Line of Defense (gastight leadthrough) is completely encapsulated. An absolute pressure measuring cell is used so that no ventilation is required.

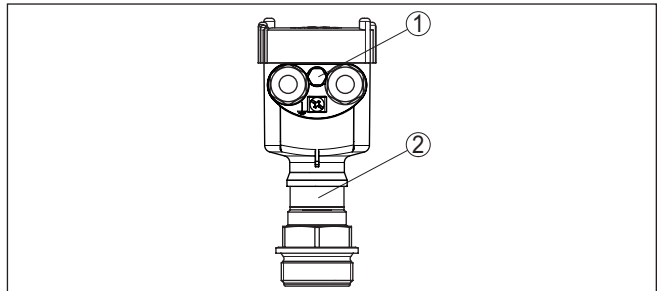

Fig. 6: Position of the filter element - gastight leadthrough

- 1 Filter element

Filter element - Position IP69K version

Fig. 7: Position of the filter element - IP69K version

- 1 Filter element

Instruments with absolute pressure have a blind plug mounted instead of the filter element.

4.3 Combination Primary - Secondary

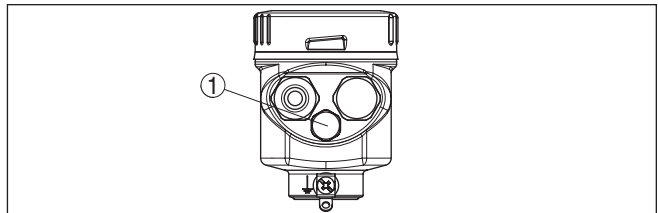
In principle, any sensor combination within the VEGABAR 80 series is allowed. The following requirements must be fulfilled:

- Configuration Primary Device suitable for electronic differential pressure
- Pressure type is identical for both sensors, i.e. relative pressure/relative pressure or absolute pressure/absolute pressure
- Primary Device measures the higher pressure
- Measurement setup as shown in the following chapters

The measuring range of each sensor is selected such that it fits the measuring loop. For this, the max. recommended turn down must be noted. See chapter " *Technical data*". It is absolutely necessary the the measuring ranges of Primary and Secondary correspond.

Measurement result = Measured value of Primary (total pressure) - measured value of Secondary (static pressure)

Depending on the application, individual combinations can result, see following examples:

Example - large vessel

Data

Application: Level measurement

Medium: Water

Vessel height: 12 m, pressure = $12 \text{ m} \times 1 \text{ Kg/m}^3 \times 9.81 \text{ m/s}^2 = 1.18 \text{ bar}$

Superimposed pressure: 1 bar

Total pressure: $1.18 \text{ bar} + 1 \text{ bar} = 2.18 \text{ bar}$

Instrument selection

Nominal measuring range Primary: 2.5 bar

Nominal measuring range Secondary: 1 bar

Turn Down: $2.5 \text{ bar} / 1.18 \text{ bar} = 2.1 : 1$

Example - small vessel

Data

Application: Level measurement

Medium: Water

Vessel height: 250 mm, pressure = $0.25 \text{ m} \times 1 \text{ Kg/m}^3 \times 9.81 \text{ m/s}^2 = 0.025 \text{ bar}$

Superimposed pressure: 350 mbar = 0.35 bar

Total pressure: $0.025 \text{ bar} + 0.35 \text{ bar} = 0.375 \text{ bar}$

Instrument selection

Nominal measuring range Primary: 0.4 bar

Nominal measuring range Secondary: 0.4 bar

Turn Down: $0.4 \text{ bar} / 0.025 \text{ bar} = 16 : 1$

Output measured values

The measuring result (level, pressure difference) as well as measured value Secondary (static or superimposed pressure) are output by the

sensor. Depending on the instrument version, output as 4 ... 20 mA signal or digitally via HART, Profibus PA or Foundation Fieldbus.

4.4 Differential pressure measurement

Measurement setup

With the Primary/Secondary combination, a gauge different measurement can be realized.

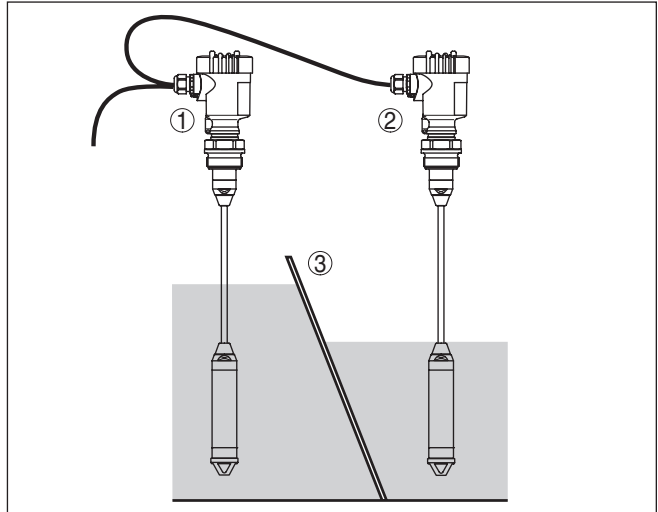

Fig. 8: Measurement setup with a level difference measurement

- 1 Primary Device
- 2 Secondary Device
- 3 Screen

4.5 Interface measurement

Measurement setup

With the Primary/Secondary combination also an interface measurement can be realised.

Requirements for a functioning measurement are:

- Vessel with changing level
- Products with steady densities
- Interface always between the measurement points
- Total level always above the upper measurement point

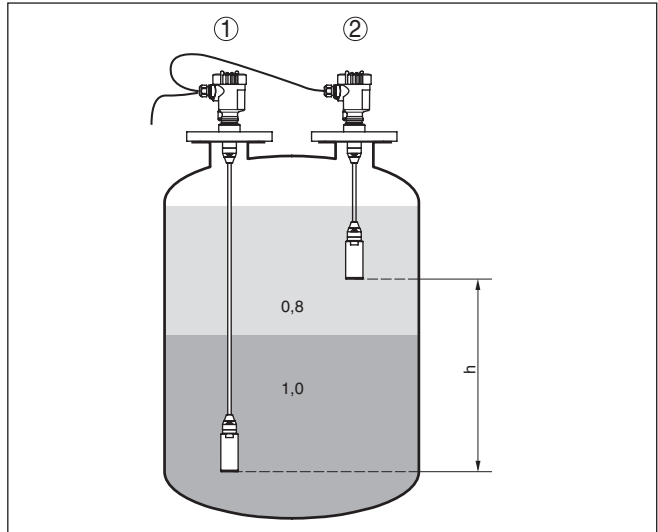

Fig. 9: Measurement setup with interface measurement, h = distance between the two measuring points

1 VEGABAR 86

2 VEGABAR 86 - Secondary Device

The interface measurement is possible in open as well as in closed vessels.

4.6 Density measurement

Measurement setup

With the Primary/Secondary combination also a density measurement can be realised.

Requirements for a functioning measurement are:

- Vessel with changing level
- Distance between the measurement points as large as possible
- Level always above the upper measuring point

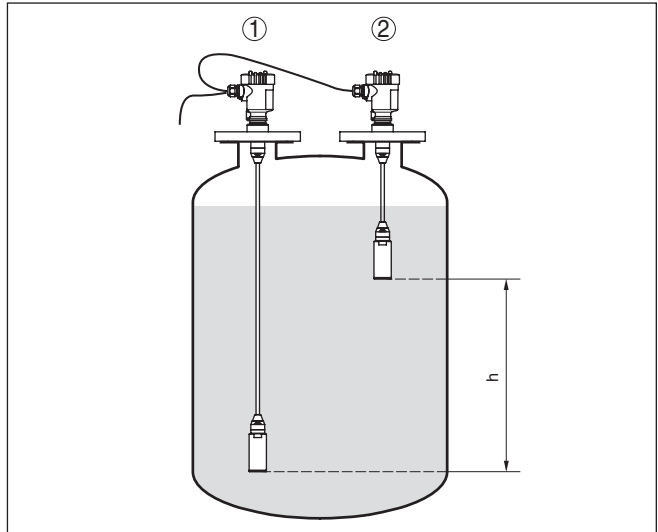

Fig. 10: Measurement setup for density measurement, h = distance between the two measuring points

1 VEGABAR 86

2 VEGABAR 86 - Secondary Device

The length distance h of the two sensors should be at least 10 %, better 20 %, of the final value of the sensor measuring range. A bigger difference increases the accuracy of the density measurement.

Slight density changes cause only slight changes of the measured differential pressure. The measuring range must hence be selected accordingly.

The density measurement is possible in open as well as in closed vessels.

4.7 Density-compensated level measurement

The Primary/Secondary combination is suitable for density-compensated level measurement in an atmospherically open vessel

Keep the following in mind when setting up the measuring system:

- Mount the Primary Device below the min. level
- Mount the Secondary Device above the Primary Devices
- Mount both sensors away from the filling stream and emptying and protected against pressure shocks from the stirrer

Measurement setup

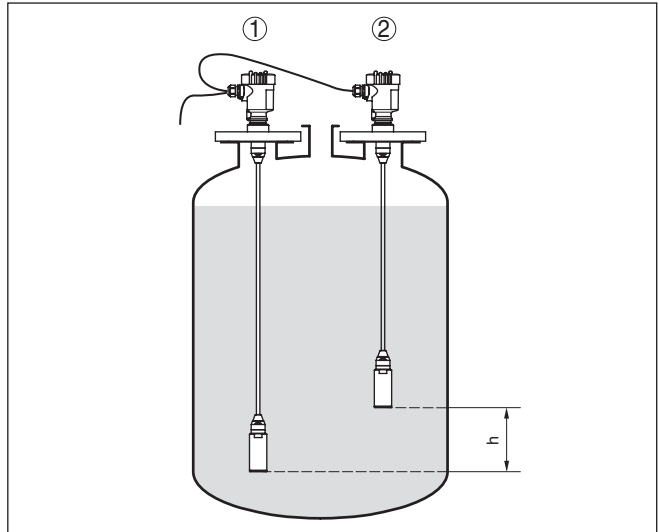

Fig. 11: Measurement setup for density-compensated level measurement, h = distance between the two measuring points

- 1 VEGABAR 86
- 2 VEGABAR 86 - Secondary Device

The length distance h of the two sensors should be at least 10 %, better 20 %, of the final value of the sensor measuring range. A bigger difference increases the accuracy of the density compensation.

The density-compensated level measurement starts with the stored density 1 kg/dm^3 . As soon as both sensors are covered, this value will be replaced by the calculated distance.

The density-compensated level measurement is only possible in open, i.e. unpressurized vessels.

4.8 External housing

Configuration

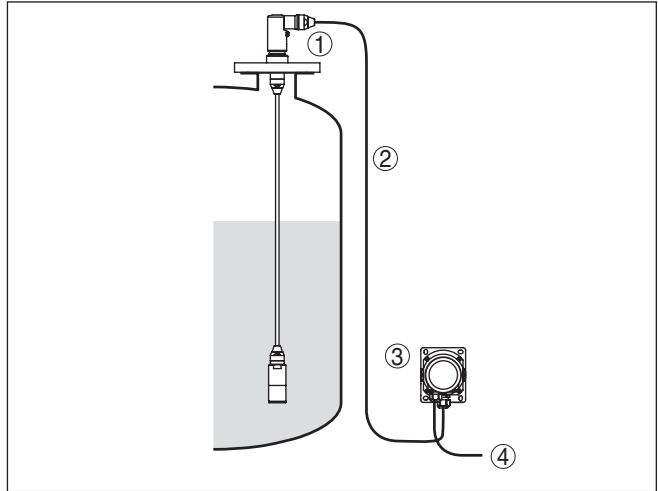

Fig. 12: Arrangement measurement loop, external housing

- 1 Sensor
- 2 Connection cable sensor, external housing
- 3 External housing
- 4 Signal cable

5 Connecting to power supply

5.1 Preparing the connection

Safety instructions

Always keep in mind the following safety instructions:

- Carry out electrical connection by trained, qualified personnel authorised by the plant operator
- If overvoltage surges are expected, overvoltage arresters should be installed



Warning:

Only connect or disconnect in de-energized state.

Voltage supply

The voltage supply and the signal transmission are carried out via the four-wire, shielded connection cable from the Primary Device.

You can find the data for this signal circuit in chapter " *Technical data*".

Connection cable

The device is connected via the supplied four-wire, shielded cable or a similar cable provided by the customer. You can find detailed information of the connection cable in chapter " *Technical data*".

Use a cable gland suitable for the cable diameter to ensure the seal effect of the cable gland (IP protection).

Cable screening and grounding

The shielding of the cable between Primary and Secondary Device must be connected on both ends to ground potential. In the sensor, the shielding is connected directly to the internal ground terminal. The ground terminal on the outside of the housing must be connected to the ground potential (low impedance).

Cable glands

Metric threads:

In the case of instrument housings with metric thread, the cable glands are screwed in at the factory. They are sealed with plastic plugs as transport protection.



Note:

You have to remove these plugs before electrical connection.

NPT thread:

In the case of instrument housings with self-sealing NPT threads, it is not possible to have the cable entries screwed in at the factory. The free openings for the cable glands are therefore covered with red dust protection caps as transport protection.



Note:

Prior to setup you have to replace these protective caps with approved cable glands or close the openings with suitable blind plugs.

On plastic housings, the NPT cable gland or the Conduit steel tube must be screwed into the threaded insert without grease.

Max. torque for all housings, see chapter " *Technical data*".

5.2 Connecting

Connection technology

The connection to the Primary Device is carried out through spring-loaded terminals in the respective housing. For this, use the supplied, confectioned cable. Solid cores as well as flexible cores with cable end sleeves are inserted directly into the terminal openings.

In case of flexible cores without end sleeves, press the terminal from above with a small screwdriver, the terminal opening is then free. When the screwdriver is released, the terminal closes again.



Information:

The terminal block is pluggable and can be removed from the electronics. To do this, lift the terminal block with a small screwdriver and pull it out. When reinserting the terminal block, you should hear it snap in.

You can find further information on the max. wire cross-section under "*Technical data - Electromechanical data*".

Connection procedure

Proceed as follows:

1. Unscrew the housing lid
2. Loosen compression nut of the cable gland and remove blind plug
3. Remove approx. 10 cm (4 in) of the cable mantle, strip approx. 1 cm (0.4 in) insulation from the individual wires or use supplied connection cable
4. Insert the cable into the sensor through the cable entry



Fig. 13: Connection steps 5 and 6

5. Insert the wire ends into the terminals according to the wiring plan
6. Check the hold of the wires in the terminals by lightly pulling on them
7. Connect the shielding to the internal ground terminal, connect the external ground terminal to potential equalisation

8. Tighten the compression nut of the cable entry gland. The seal ring must completely encircle the cable
 9. Unscrew the blind plug on the Primary, screw in the supplied cable gland
 10. Connection cable to Primary, see steps 3 to 8
 11. Screw the housing lid back on
- The electrical connection is finished.

5.3 Single chamber housing



The following illustration applies to the non-Ex, Ex ia and Ex d ia version.

Electronics and connection compartment

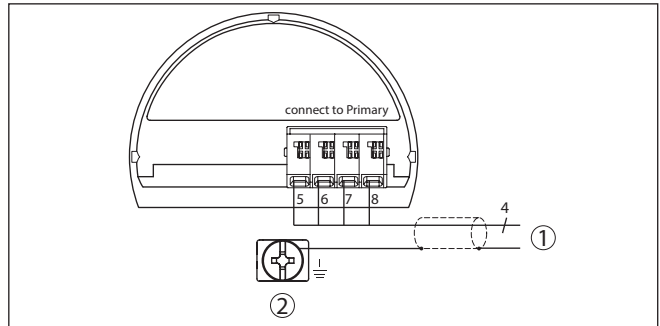

Fig. 14: Wiring plan VEGABAR 86 Secondary Device

- 1 To the Primary Device
- 2 Ground terminal for connection of the cable shielding ¹⁾

¹⁾ Connect shielding here. Connect ground terminal on the outside of the housing to ground as prescribed. The two terminals are galvanically connected.

5.4 External housing with version IP68 (25 bar)

Overview

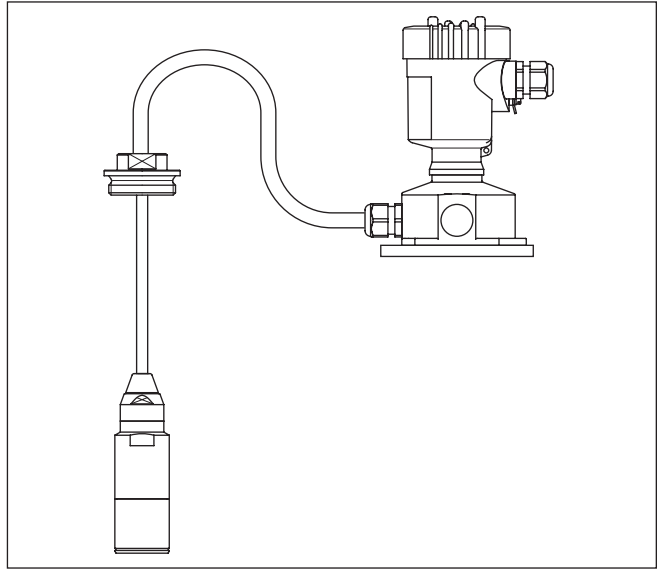

Fig. 15: VEGABAR 86 in IP68 version 25 bar, non-Ex and axial cable outlet, external housing

Electronics and connection compartment for power supply

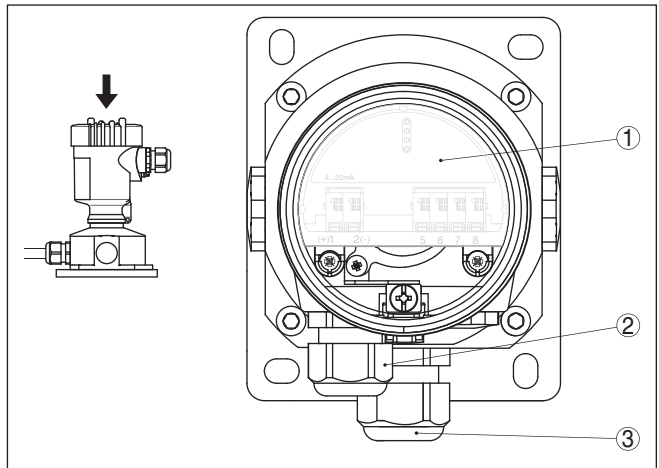

Fig. 16: Electronics and connection compartment

- 1 Electronics module
- 2 Cable gland for voltage supply
- 3 Cable gland for connection cable, transmitter

Terminal compartment, housing socket

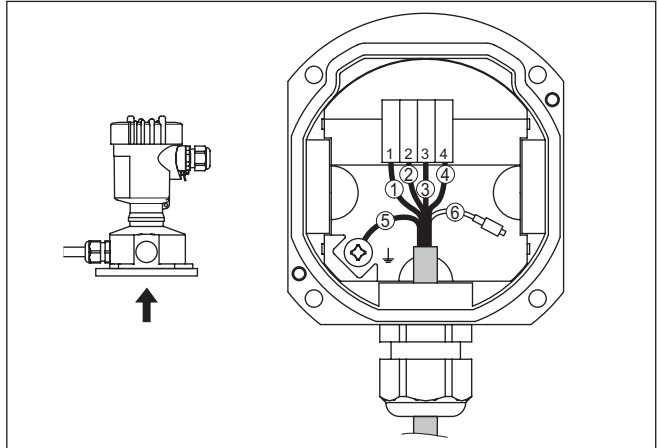

Fig. 17: Connection of the process component in the housing base

- 1 Yellow
- 2 White
- 3 Red
- 4 Black
- 5 Shielding
- 6 Breather capillaries

Electronics and connection compartment

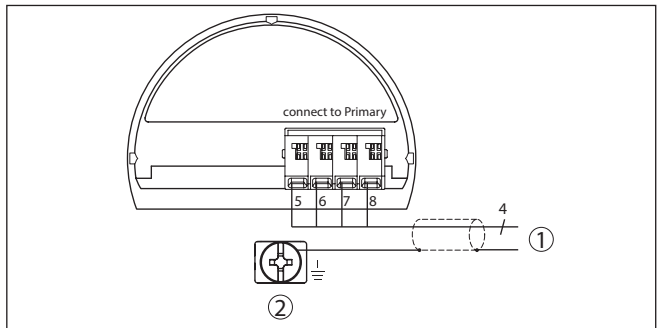

Fig. 18: Wiring plan VEGABAR 86 Secondary Device

- 1 To the Primary Device
- 2 Ground terminal for connection of the cable screening²⁾

²⁾ Connect shielding here. Connect ground terminal on the outside of the housing to ground as prescribed. The two terminals are galvanically connected.

Connection example, electronic differential pressure

5.5 Connection example

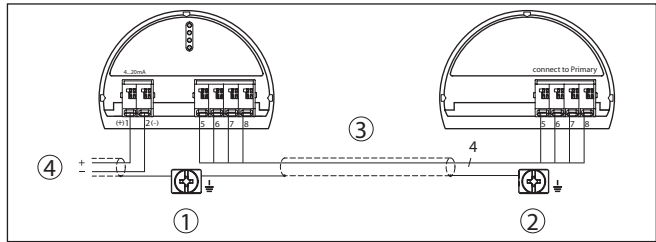

Fig. 19: Connection example, electronic differential pressure

- 1 Primary Device
- 2 Secondary Device
- 3 Connection cable
- 4 Supply and signal circuit Primary Device

The connection between Primary and Secondary Device is carried out acc. to the table:

Primary Device	Secondary Device
Terminal 5	Terminal 5
Terminal 6	Terminal 6
Terminal 7	Terminal 7
Terminal 8	Terminal 8

6 Set up with the display and adjustment module

6.1 Parameter adjustment - Extended adjustment

For technically demanding measuring points, you can carry out extended settings in "Extended adjustment".

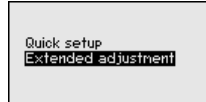

Main menu

The main menu is divided into five sections with the following functions:

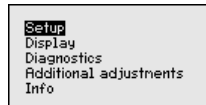

Setup: Settings, e.g., for measurement loop name, application, units, position correction, adjustment, signal output

Display: Settings, e.g., for language, measured value display, lighting

Diagnosis: Information, e.g. on instrument status, peak indicator, measurement reliability, simulation

Additional adjustments: PIN, date/time, reset, copy function

Info: Instrument name, hardware and software version, date of manufacture, sensor features

In the main menu item "Setup", the individual submenu items should be selected one after the other and provided with the correct parameter values.

The following submenu points are available:

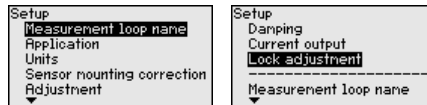

In the following section, the menu items from the menu "Setup" for electronic differential pressure measurement are described in detail. Depending on the selected application, different sections are relevant.



Information:

Further menu items of the menu "Setup" as well as the complete menus "Display", "Diagnostics", "Additional adjustments" and "Info" are described in the operating instructions of the respective Primary Device.

6.1.1 Setup

In this menu item you activate/deactivate the Secondary Device for electronic differential pressure and select the application.

Application

The VEGABAR 86 in conjunction with a Secondary Device can be used for flow, differential pressure, density and interface measurement. The default setting is differential pressure measurement. Switchover is carried out in the adjustment menu.

If you have connected a Secondary Device, you confirm this with "Activate".



Note:

It is absolutely necessary to activate the Secondary Device to have the applications displayed in the electronic differential pressure measurement menus.

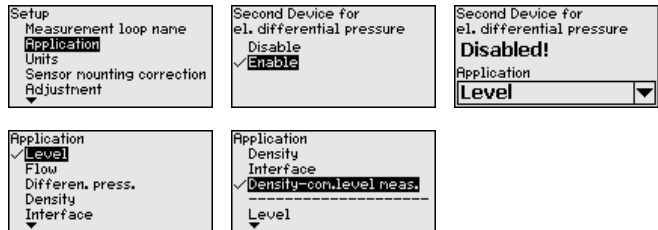

Enter the requested parameters via the appropriate keys, save your settings with **[OK]** and jump to the next menu item with the **[ESC]** and the **[->]** key.

Units

In this menu item, you determine the units for the "Min. adjustment/Zero" and "Max. adjustment/Span" as well as the static pressure.

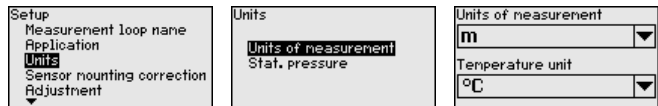

If the level should be adjusted in a height unit, the density of the medium must also be entered later during the adjustment.

In addition, the unit is determined in the menu item "Peak indicator temperature".

Enter the requested parameters via the appropriate keys, save your settings with **[OK]** and jump to the next menu item with the **[ESC]** and the **[->]** key.

Position correction

Especially with chemical seal systems, the installation position of the instrument can shift (offset) the measured value. Position correction compensates this offset. In the process, the actual measured value is taken over automatically. With relative pressure measuring cells a manual offset can also be carried out.

There are the following possibilities for a position correction with a Primary/Secondary combination

- Automatic correction for both sensors
- Manual correction for the Primary (differential pressure)
- Manual correction for the Secondary (static pressure)

With a Primary/Secondary combination in the application " *Density-compensated level measurement*" there are the following additional options for the position correction

- Automatic correction, Primary (level)
- Manual correction for the Primary (level)

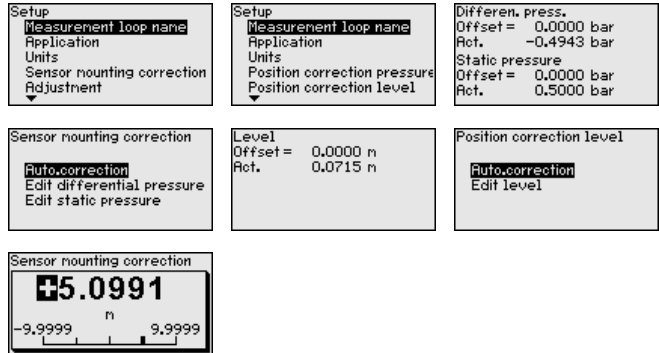

During an automatic position correction, the current measured value is accepted as the correction value. This value must not be influenced/corrupted by product coverage or static pressure.

In case of a manual position correction, the offset value is determined by the user. Select for this purpose the function " *Edit*" and enter the requested value.

Save your settings with [**OK**] and move with [**ESC**] and [**->**] to the next menu item.

After the position correction is carried out, the actual measured value is corrected to 0. The corrective value appears with an inverse sign as offset value in the display.

The position correction can be repeated any number of times.

Parameterization example

VEGABAR 86 always measures pressure independently of the process variable selected in the menu item " *Application*". To output the selected process variable correctly, an allocation of the output signal to 0 % and 100 % must be carried out (adjustment).

With the application " *Interface*" the hydrostatic pressure at min. and max. height of the interface is entered for adjustment. See the following example:

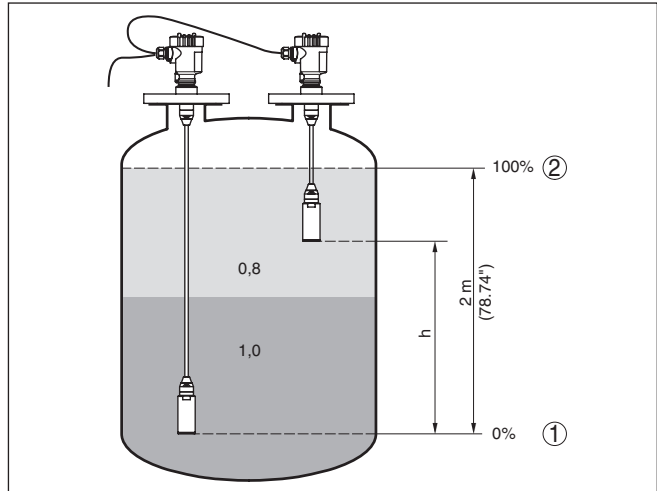

Fig. 20: Parameter adjustment example "Min./max. adjustment, interface measurement"

- 1 Min. interface = 0 % correspond to 0.0 mbar
- 2 Max. interface = 100 % correspond to 490.5 mbar
- 3 VEGABAR 86
- 4 VEGABAR 86 - Secondary Device

If these values are not known, an adjustment with interface layers of for example 10 % and 90 % is also possible. By means of these settings, the layer of the actual interface is then calculated.

The real product level during the adjustment is not important, because the adjustment is always carried out without changing the product level. These settings can be made ahead of time without the instrument having to be installed.



Note:

If the adjustment ranges are exceeded, the entered value will not be accepted. Editing can be interrupted with **[ESC]** or corrected to a value within the adjustment ranges.

Min. adjustment - Level

Proceed as follows:

1. Select the menu item "Setup" with **[>]** and confirm with **[OK]**. Now select with **[>]** the menu item "Adjustment", then "Min. adjustment" and confirm with **[OK]**.

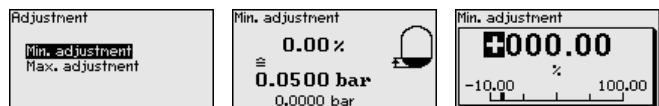

2. Edit the percentage value with **[OK]** and set the cursor to the requested position with **[>]**.
3. Set the requested percentage value (e.g. 10 %) with **[+]** and save with **[OK]**. The cursor jumps now to the pressure value.

4. Enter the pressure value corresponding to the min. level (e.g. 0 mbar).
5. Save settings with **[OK]** and move with **[ESC]** and **[>]** to the max. adjustment.

The min. adjustment is finished.

For an adjustment with filling, simply enter the actual measured value indicated at the bottom of the display.

Max. adjustment - Level

Proceed as follows:

1. Select with **[>]** the menu item " *Max. adjustment*" and confirm with **[OK]**.



2. Edit the percentage value with **[OK]** and set the cursor to the requested position with **[>]**.
3. Set the requested percentage value (e.g. 90 %) with **[+]** and save with **[OK]**. The cursor jumps now to the pressure value.
4. Enter the pressure value for the full vessel (e.g. 900 mbar) corresponding to the percentage value.
5. Save settings with **[OK]**

The max. adjustment is finished.

For an adjustment with filling, simply enter the actual measured value indicated at the bottom of the display.

Min. adjustment flow

Proceed as follows:

1. Select the menu item " *Setup*" with **[>]** and confirm with **[OK]**. Now select with **[>]** the menu item " *Min. adjustment*" and confirm with **[OK]**.

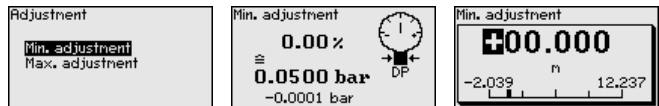

2. Edit the mbar value with **[OK]** and set the cursor to the requested position with **[>]**.
3. Set the requested mbar value with **[+]** and store with **[OK]**.
4. Change with **[ESC]** and **[>]** to the span adjustment

With flow in two directions (bidirectional) a negative differential pressure is also possible. The maximum negative pressure must then be entered for the min. adjustment. For linearization, select " *bidirectional*" or " *bidirectional-extracted by root*" accordingly, see menu item " *Linearization*".

The min. adjustment is finished.

For an adjustment with pressure, simply enter the actual measured value indicated at the bottom of the display.

Max. adjustment flow

Proceed as follows:

1. Select with **[>]** the menu item Max. adjustment and confirm with **[OK]**.

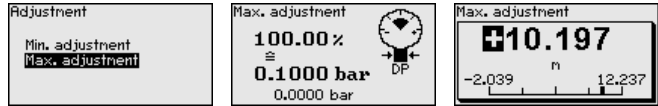

2. Edit the mbar value with **[OK]** and set the cursor to the requested position with **[>]**.
3. Set the requested mbar value with **[+]** and store with **[OK]**.

The max. adjustment is finished.

For an adjustment with pressure, simply enter the actual measured value indicated at the bottom of the display.

Zero adjustment differential pressure

Proceed as follows:

1. Select the menu item "Setup" with **[>]** and confirm with **[OK]**.
Now select with **[>]** the menu item "Zero adjustment" and confirm with **[OK]**.

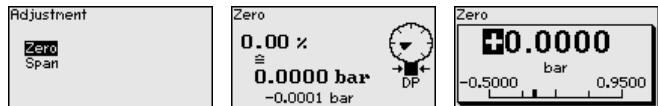

2. Edit the mbar value with **[OK]** and set the cursor to the requested position with **[>]**.
3. Set the requested mbar value with **[+]** and store with **[OK]**.
4. Change with **[ESC]** and **[>]** to the span adjustment

The zero adjustment is finished.

**Information:**

The Zero adjustment shifts the value of the span adjustment. The span, i.e. the difference between these values, however, remains unchanged.

For an adjustment with pressure, simply enter the actual measured value indicated at the bottom of the display.

Span adjustment differential pressure

Proceed as follows:

1. Select with **[>]** the menu item "Span adjustment" and confirm with **[OK]**.



2. Edit the mbar value with **[OK]** and set the cursor to the requested position with **[>]**.
3. Set the requested mbar value with **[+]** and store with **[OK]**.

The span adjustment is finished.

For an adjustment with pressure, simply enter the actual measured value indicated at the bottom of the display.

Distance density

Proceed as follows:

- Select in the menu item "Setup" with [->] "Adjustment" and confirm with [OK]. Now confirm the menu item "Distance" with [OK].



- Edit the sensor distance with [OK] and set the cursor to the requested position with [->].
- Set the distance with [+] and save with [OK].

The adjustment of the distance is hence finished.

Min. adjustment density

Proceed as follows:

- Select the menu item "Setup" with [->] and confirm with [OK]. Now select with [->] the menu item "Min. adjustment" and confirm with [OK].

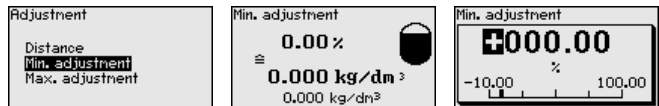

- Edit the percentage value with [OK] and set the cursor to the requested position with [->].
- Set the requested percentage value with [+] and save with [OK]. The cursor jumps now to the density value.
- Enter the min. density corresponding to the percentage value.
- Save settings with [OK] and move with [ESC] and [->] to the max. adjustment.

The min. adjustment for density is finished.

Max. adjustment density

Proceed as follows:

- Select the menu item "Setup" with [->] and confirm with [OK]. Now select with [->] the menu item "Max. adjustment" and confirm with [OK].



- Edit the percentage value with [OK] and set the cursor to the requested position with [->].
- Set the requested percentage value with [+] and save with [OK]. The cursor jumps now to the density value.
- Enter the max. density value corresponding to the percentage value.

The max. adjustment for density is finished.

Distance interface

Proceed as follows:

1. Select in the menu item " *Setup*" with [->] " *Adjustment*" and confirm with [OK]. Now confirm the menu item " *Distance*" with [OK].

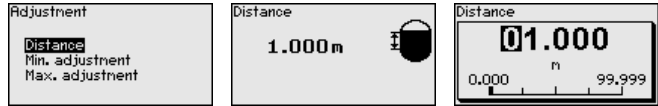

2. Edit the sensor distance with [OK] and set the cursor to the requested position with [->].
3. Set the distance with [+] and save with [OK].

The adjustment of the distance is hence finished.

Min. adjustment interface

Proceed as follows:

1. Select the menu item " *Setup*" with [->] and confirm with [OK]. Now select with [->] the menu item " *Min. adjustment*" and confirm with [OK].

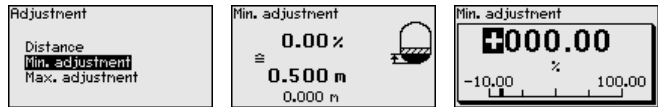

2. Edit the percentage value with [OK] and set the cursor to the requested position with [->].
3. Set the requested percentage value with [+] and save with [OK]. The cursor jumps now to the height value.
4. Enter the min. height of the interface corresponding to the percentage value.
5. Save settings with [OK] and move with [ESC] and [->] to the max. adjustment.

The min. adjustment for interface is thus finished.

Max. adjustment interface

Proceed as follows:

1. Select the menu item " *Setup*" with [->] and confirm with [OK]. Now select with [->] the menu item " *Max. adjustment*" and confirm with [OK].

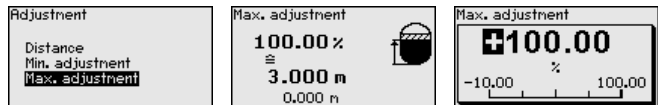

2. Edit the percentage value with [OK] and set the cursor to the requested position with [->].
3. Set the requested percentage value with [+] and save with [OK]. The cursor jumps now to the height value.
4. Enter the max. height of the interface corresponding to the percentage value.

The max. adjustment for interface is finished.

Distance level density-compensated

Proceed as follows:

- Select in the menu item "Setup" with [->] "Adjustment" and confirm with [OK]. Now confirm the menu item "Distance" with [OK].



- Edit the sensor distance with [OK] and set the cursor to the requested position with [->].
- Set the distance with [+] and save with [OK].

The adjustment of the distance is hence finished.

Min. adjustment level density-compensated

Proceed as follows:

- Select the menu item "Setup" with [->] and confirm with [OK]. Now select with [->] the menu item "Adjustment", then "Min. adjustment" and confirm with [OK].

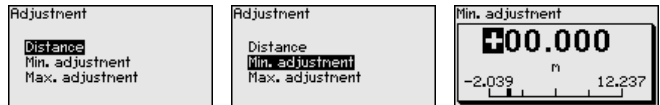

- Edit the percentage value with [OK] and set the cursor to the requested position with [->].
- Set the requested percentage value (e.g. 0 %) with [+] and save with [OK]. The cursor jumps now to the pressure value.
- Enter the value corresponding to the min. level (e.g. 0 m).
- Save settings with [OK] and move with [ESC] and [->] to the max. adjustment.

The min. adjustment is finished.

For an adjustment with filling, simply enter the actual measured value indicated at the bottom of the display.

Max. adjustment level density-compensated

Proceed as follows:

- Select with [->] the menu item Max. adjustment and confirm with [OK].

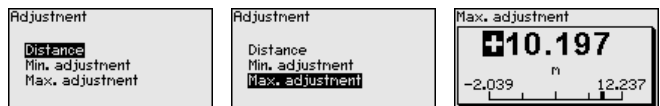

- Edit the percentage value with [OK] and set the cursor to the requested position with [->].
- Set the requested percentage value (e.g. 100 %) with [+] and save with [OK]. The cursor jumps now to the pressure value.
- Enter the value for the full vessel (e.g. 10 m) corresponding to the percentage value.
- Save settings with [OK]

The max. adjustment is finished.

Linearisation

For an adjustment with filling, simply enter the actual measured value indicated at the bottom of the display.

A linearization is necessary for all applications in which the measured process variable does not increase linearly with the measured value. This applies for example to the flow measured via the differential pressure or the vessel volume measured via the level. Corresponding linearization curves are preprogrammed for such cases. They represent the correlation between the measured value percentage and process variable. The linearization applies to the measured value indication and the current output.

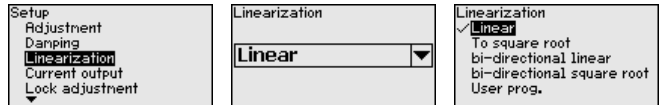

With flow measurement and selection "*Linear*" display and output (percentage/current) are linear to "**Differential pressure**". This can be used, for example, to feed a flow computer.

With flow measurement and selection "*Extraction by root*" display and output (percentage/current) are linear to "**Flow**".³⁾

With flow in two directions (bidirectional) a negative differential pressure is also possible. This must already be taken into account in menu item "*Min. adjustment flow*".



Caution:

Note the following, if the respective sensor is used as part of an over-fill protection system according to WHG:

If a linearisation curve is selected, the measuring signal is no longer necessarily linear to the filling height. This must be considered by the user especially when setting the switching point on the limit signal transmitter.

AI FB1

Since the parameter adjustment of the Function Block 1 (FB1) is very comprehensive, it was divided into various submenu items.

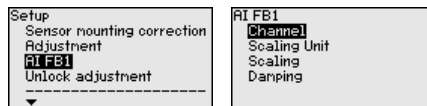

AI FB1 - Channel

In menu item "*Channel*" you determine the input signal for further processing in AI FB 1.

As input signals, the output values of Transducer Block (TB) can be selected.

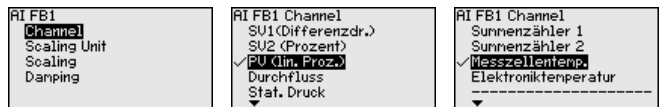

³⁾ The device assumes an approximately constant temperature and static pressure and calculates the flow rate from the measured differential pressure using the characteristic curve extracted by root.

6.1.2 Display

Display value 1 and 2 - 4 ... 20 mA

In this menu item, you define which measured value is displayed.



The default setting for the displayed value is " *Differential pressure*".

Display format 1 and 2

In this menu item you define the number of decimal positions with which the measured value is displayed.

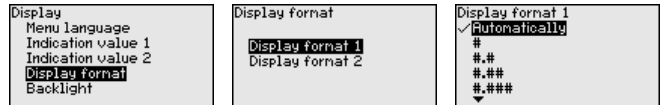

The default setting for the display format is " *Automatic*".

Display value 1 and 2 - bus systems

In this menu item, you define which measured value is displayed.

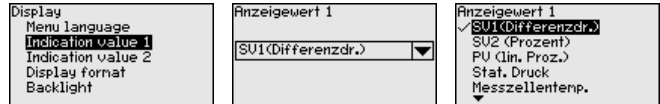

The default setting for the displayed value is " *Differential pressure*".

Display format 1 and 2

In this menu item you define the number of decimal positions with which the measured value is displayed.

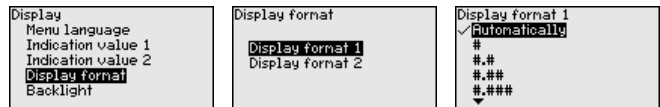

The default setting for the display format is " *Automatic*".

6.1.3 Diagnostics

Peak indicator, pressure

The respective min. and max. measured values for the differential pressure and static pressure are stored in the sensor. In menu item " *Peak indicator, pressure*", both values are displayed.

In another window you can carry out a reset of the peak values separately.

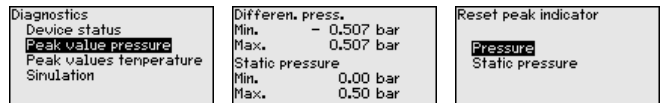

Simulation 4 ... 20 mA/HART

In this menu item you can simulate measured values. This allows the signal path to be tested, e.g. through downstream indicating instruments or the input card of the control system.

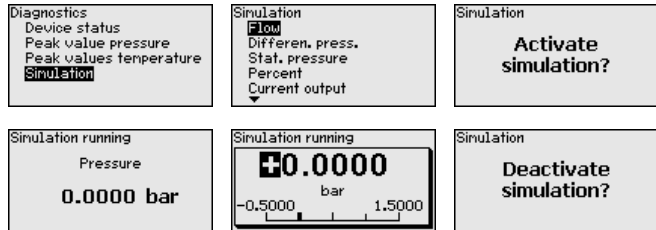

Select the requested simulation variable and set the requested value.

To deactivate the simulation, you have to push the **[ESC]** key and confirm the message " *Deactivate simulation*" with the **[OK]** key.



Caution:

During simulation, the simulated value is output as 4 ... 20 mA current value and as digital HART signal. The status message within the context of the asset management function is " *Maintenance*".



Note:

Without manual deactivation, the sensor terminates the simulation automatically after 60 minutes.

Simulation bus systems

In this menu item you can simulate measured values. This allows the signal path to be tested, e.g. through downstream indicating instruments or the input card of the control system.

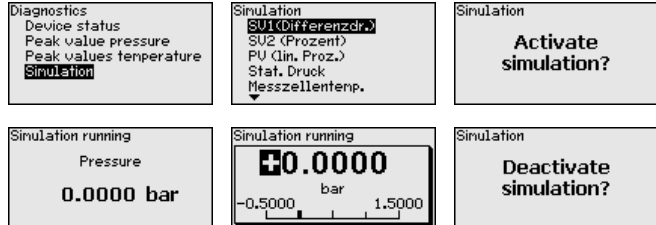

Select the requested simulation variable and set the requested value.

To deactivate the simulation, you have to push the **[ESC]** key and confirm the message " *Deactivate simulation*" with the **[OK]** key.



Caution:

During simulation, the simulated value is output as digital signal. The status message along with the Asset Management function is " *Maintenance*".



Note:

Without manual deactivation, the sensor terminates the simulation automatically after 60 minutes.

6.1.4 Additional adjustments

Current output 1 and 2 (size)

In menu item " *Current output, variable*" you specify which measured variable is output via the current output.

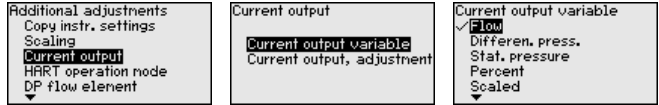

The following selection is possible depending on the selected application:

- Flow
- Height - Interface
- Density
- Differential pressure
- Static pressure
- Percent
- Scaled
- Percent linearized
- Measuring cell temperature (ceramic measuring cell)
- Electronics temperature

Characteristics values DP flow element

In this menu item, the units for the DP flow element are determined and the selection of mass or volume flow is carried out.

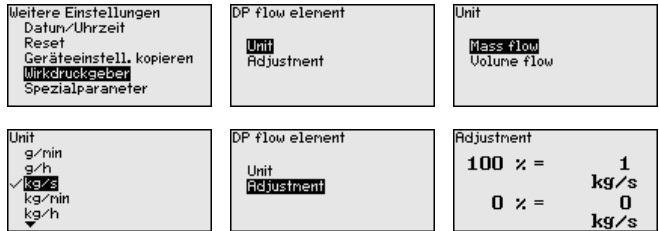

Furthermore the adjustment for the volume or mass flow rate at 0 % or 100 % is carried out.

6.2 Menu overview

The following tables show the adjustment menu of the instrument. Depending on the instrument version or application, all menu items may not be available or some may be differently assigned.



Note:

You can find further menu items in the operating instructions of the respective Primary Device.

Setup

Menu item	Parameter	Default setting
Measurement loop name	19 alphanumeric characters/special characters	Sensor
Application	Application	Level
	Secondary Device for electronic differential pressure	Deactivated

Menu item	Parameter	Default setting
Units	Unit of measurement	mbar (with nominal measuring range ≤ 400 mbar) bar (with nominal measuring ranges ≥ 1 bar)
	Static pressure	bar
Position correction		0.00 bar
Adjustment	Distance (with density and interface)	1.00 m
	Zero/Min. adjustment	0.00 bar 0.00 %
	Span/Max. adjustment	Nominal measuring range in bar 100.00 %
Damping	Integration time	0.0 s
Linearisation	Linear, cylindrical tank, ... user-defined	Linear
Current output	Current output - Mode	Output characteristics 4 ... 20 mA Reaction when malfunctions occur ≤ 3.6 mA
	Current output - Min./Max.	3.8 mA 20.5 mA
Lock adjustment	Blocked, released	Last setting

Display

Menu item	Default setting
Menu language	Order-specific
Displayed value 1	Current output in %
Displayed value 2	Ceramic measuring cell: Measuring cell temperature in °C Metallic measuring cell: Electronics temperature in °C
Display format	Number of positions after the decimal point, automatically
Backlight	Switched on

Diagnostics

Menu item	Parameter	Default setting
Device status		-
Peak indicator	Pressure	Current pressure measured value
Peak indicator temp.	Temperature	Actual measuring cell and electronic temperature

Menu item	Parameter	Default setting
Simulation	Pressure, percent, signal output, linearized percent, measuring cell temperature, electronics temperature	-

Additional adjustments

Menu item	Parameter	Default setting
Date/Time		Actual date/Actual time
Reset	Delivery status, basic settings	
Copy instrument settings	Read from sensor, write into sensor	
Scaling	Scaling size	Volume in l
	Scaling format	0 % corresponds to 0 l 100 % corresponds to 0 l
Current output	Current output - Meas. variable	Lin. percent - Level
	Current output - Adjustment	0 ... 100 % correspond to 4 ... 20 mA
HART mode		Address 0
DP flow element	Unit	m ³ /s
	Adjustment	0.00 % correspond to 0.00 m ³ /s 100.00 %, 1 m ³ /s
Special parameters	Service-Login	No reset

Info

Menu item	Parameter
Device name	VEGABAR 86
Instrument version	Hardware and software version
Factory calibration date	Date
Sensor characteristics	Order-specific characteristics

7 Diagnosis, asset management and service

7.1 Maintenance

Maintenance

If the device is used properly, no special maintenance is required in normal operation.

Precaution measures against buildup

In some applications, product buildup on the diaphragm can influence the measuring result. Depending on the sensor and application, take precautions to ensure that heavy buildup, and especially a hardening thereof, is avoided.

Cleaning

The cleaning helps that the type label and markings on the instrument are visible.

Take note of the following:

- Use only cleaning agents which do not corrode the housings, type label and seals
- Use only cleaning methods corresponding to the housing protection rating

7.2 Rectify faults

Reaction when malfunction occurs

The operator of the system is responsible for taking suitable measures to rectify faults.

Fault rectification

The first measures are:

- Evaluation of fault messages
- Checking the output signal
- Treatment of measurement errors

A smartphone/tablet with the adjustment app or a PC/notebook with the software PACTware and the suitable DTM offer you further comprehensive diagnostic possibilities. In many cases, the causes can be determined in this way and the faults eliminated.

Reaction after fault rectification

Depending on the reason for the fault and the measures taken, the steps described in chapter "Setup" must be carried out again or must be checked for plausibility and completeness.

24 hour service hotline

Should these measures not be successful, please call in urgent cases the VEGA service hotline under the phone no. **+49 1805 858550**.

The hotline is also available outside normal working hours, seven days a week around the clock.

Since we offer this service worldwide, the support is provided in English. The service itself is free of charge, the only costs involved are the normal call charges.

7.3 Exchanging the electronics module

In case of a defect, the user can replace the electronics module with another one of identical type.



In Ex applications, only instruments and electronics modules with appropriate Ex approval may be used.

If there is no electronics module available on site, one can be ordered from the agency serving you.

7.4 Exchange process module on version IP68 (25 bar)

On version IP68 (25 bar), the user can exchange the process module on site. Connection cable and external housing can be kept.

Required tools:

- Hexagon key wrench, size 2



Caution:

The exchange may only be carried out in the complete absence of line voltage.



In Ex applications, only a replacement part with appropriate Ex approval may be used.



Caution:

During exchange, protect the inner side of the parts against contamination and moisture.

Proceed as follows when carrying out the exchange:

1. Loosen the fixing screw with the hexagon key wrench
2. Carefully detach the cable assembly from the process module

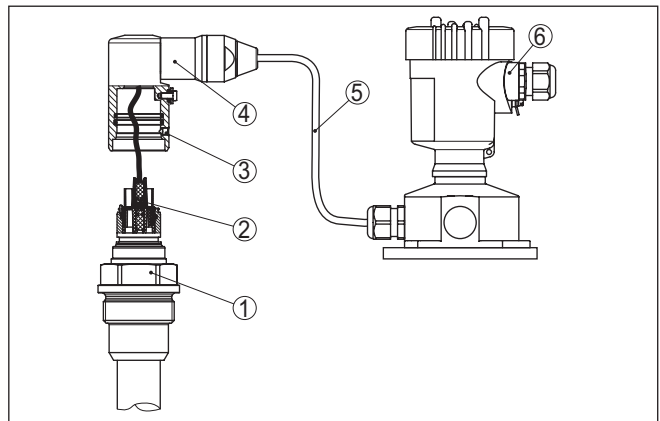

Fig. 21: VEGABAR 86 in IP68 version, 25 bar and lateral cable outlet, external housing

- 1 Process module
- 2 Plug connector
- 3 Cable assembly
- 4 Connection cable
- 5 External housing

3. Loosen the plug connector

4. Mount the new process module on the measuring point
5. Plug the connector back in
6. Mount the cable assembly on the process module and turn it to the desired position
7. Tighten the fixing screw with the hexagon key wrench

The exchange is finished.

7.5 How to proceed if a repair is necessary

On our homepage you will find detailed information on how to proceed in the event of a repair.

So that we can carry out the repair quickly and without queries, generate a instrument return form there with the data of your device.

You will need:

- The serial number of the instrument
- A short description of the problem
- Details of the medium

Print the generated instrument return form.

Clean the instrument and pack it damage-proof.

Send the printed instrument return form and possibly a safety data sheet together with the device.

You will find the address for the return on the generated instrument return form.

8 Dismount

8.1 Dismounting steps

To remove the device, carry out the steps in chapters " *Mounting*" and " *Connecting to power supply*" in reverse.



Warning:

When dismantling, pay attention to the process conditions in vessels or pipelines. There is a risk of injury, e.g. due to high pressures or temperatures as well as aggressive or toxic media. Avoid this by taking appropriate protective measures.

8.2 Disposal



Pass the instrument on to a specialised recycling company and do not use the municipal collecting points.

Remove any batteries in advance, if they can be removed from the device, and dispose of them separately.

If personal data is stored on the old device to be disposed of, delete it before disposal.

If you have no way to dispose of the old instrument properly, please contact us concerning return and disposal.

9 Supplement

9.1 Technical data

Note for approved instruments

The technical data in the respective safety instructions which are included in delivery are valid for approved instruments (e.g. with Ex approval). These data can differ from the data listed herein, for example regarding the process conditions or the voltage supply.

All approval documents can be downloaded from our homepage.

Materials, weights, tensile force

Materials, wetted parts

Process fitting	316L, PVDF, Duplex (1.4462), Titanium
Diaphragm	Sapphire-ceramic® (> 99.9 % Al ₂ O ₃ ceramic)
Joining material, diaphragm/base element of measuring cell	Glass (with double and form seal, non-wetted parts)
Measuring cell seal	FKM (VP2/A, A+P 70.16), EPDM (A+P 70.10-02), FFKM (Kalrez 6375, Perlast G74S, Perlast G75B)
Transmitter	316L, PVDF
Cable assembly	Duplex (1.4462)
Suspension cable	PE (KTW-approved), FEP, PUR
Seal, suspension cable	FKM, FEP
Connection tube	316L
Measuring cell seal	FKM (VP2/A) - FDA and KTW approved, FFKM (Kalrez 6375), EPDM (A+P 70.10-02)
Diaphragm	Sapphire-ceramic® (> 99.9 % Al ₂ O ₃ ceramic)
Measuring cell seal	FKM (VP2/A) - FDA and KTW approved, FFKM (Kalrez 6375, Perlast G74S, Perlast G75B), EPDM (A+P 70.10-02)
Protective cap	PFA
Seal for process fitting (in the scope of delivery)	
– Thread G1½ (DIN 3852-A)	Klingersil C-4400
– Unassembled screw connection	Klingersil C-4400

Materials, non-wetted parts

Housing	
– Plastic housing	Plastic PBT (Polyester)
– Aluminium die-cast housing	Aluminium die-casting AlSi10Mg, powder-coated (Basis: Polyester)
– Stainless steel housing	316L
– Cable gland	PA, stainless steel, brass
– Sealing, cable gland	NBR
– Blind plug, cable gland	PA
– Seal between housing and housing lid	Silicone SI 850 R, NBR silicone-free

- Inspection window housing cover	Polycarbonate (UL-746-C listed), glass ⁴⁾
- Ground terminal	316L
External housing	
- Housing	Plastic PBT (Polyester), 316L
- Socket, wall mounting plate	Plastic PBT (Polyester), 316L
- Seal between base and wall mounting plate	EPDM (fixed connected)
Seal, housing lid	Silicone SI 850 R, NBR silicone-free, EPDM (coating-compatible)
Inspection window in housing cover	Polycarbonate, UL746-C listed (with Ex d version: glass)
Straining clamp	1.4301
Unassembled screw connection	316L, PVDF
Lock fitting	316L, PVDF
Ground terminal	316Ti/316L
Connection cable to Primary Device	PE, PUR

Materials, transmitter protection

Transport protective cap, transmitter ø 22 mm	PE
Transport and mounting protection, transmitter ø 32 mm	PA
transport protection net	PE

Weights

Basic weight	0.7 kg (1.543 lbs)
Suspension cable	0.1 kg/m (0.07 lbs/ft)
Connection tube	1.5 kg/m (1 lbs/ft)
Straining clamp	0.2 kg (0.441 lbs)
Unassembled screw connection	0.4 kg (0.882 lbs)

Tensile force

- Tensile force suspension cable	max. 500 N (112.4045 lbf)
----------------------------------	---------------------------

Torques

Max. torque for process fitting	
- G1½	200 Nm (147.5 lbf ft)
Max. torque for NPT cable glands and Conduit tubes	
- Plastic housing	10 Nm (7.376 lbf ft)
- Aluminium/Stainless steel housing	50 Nm (36.88 lbf ft)

Input variable

The specifications are only an overview and refer to the measuring cell. Limitations due to the material and version of the process fitting as well as the selected pressure type are possible. The specifications on the nameplate apply. ⁵⁾

⁴⁾ Glass with Aluminium and stainless steel (precision casting) housing
⁵⁾ Data on overload capability apply for reference temperature.

Nominal measuring ranges and overload capability in bar/kPa

Nominal range	Overload capability	
	Maximum pressure	Minimum pressure
Gauge pressure		
0 ... +0.025 bar/0 ... +2.5 kPa	+5 bar/+500 kPa	-0.05 bar/-5 kPa
0 ... +0.1 bar/0 ... +10 kPa	+15 bar/+1500 kPa	-0.2 bar/-20 kPa
0 ... +0.4 bar/0 ... +40 kPa	+25 bar/+2500 kPa	-0.8 bar/-80 kPa
0 ... +1 bar/0 ... +100 kPa	+25 bar/+2500 kPa	-1 bar/-100 kPa
0 ... +2.5 bar/0 ... +250 kPa	+25 bar/+2500 kPa	-1 bar/-100 kPa
0 ... +5 bar/0 ... +500 kPa	+25 bar/+2500 kPa	-1 bar/-100 kPa
0 ... +10 bar/0 ... +1000 kPa	+25 bar/+2500 kPa	-1 bar/-100 kPa
0 ... +25 bar/0 ... +2500 kPa	+25 bar/+2500 kPa	-1 bar/-100 kPa
Absolute pressure		
0 ... 1 bar/0 ... 100 kPa	25 bar/2500 kPa	0 bar abs.
0 ... 2.5 bar/0 ... 250 kPa	25 bar/2500 kPa	0 bar abs.
0 ... +5 bar/0 ... +500 kPa	25 bar/2500 kPa	0 bar abs.
0 ... 10 bar/0 ... 1000 kPa	25 bar/2500 kPa	0 bar abs.
0 ... 25 bar/0 ... 2500 kPa	25 bar/2500 kPa	0 bar abs.

Nominal measuring ranges and overload capacity in psi

Nominal range	Overload capability	
	Maximum pressure	Minimum pressure
Gauge pressure		
0 ... +0.4 psig	+75 psig	-0.7 psig
0 ... +1.5 psig	+225 psig	-3.0 psig
0 ... +5 psig	+360 psig	-11.50 psig
0 ... +15 psig	+360 psig	-14.51 psig
0 ... +30 psig	+360 psig	-14.51 psig
0 ... +150 psig	+360 psig	-14.51 psig
0 ... +300 psig	+360 psig	-14.51 psig
0 ... +900 psig	+360 psig	-14.51 psig
Absolute pressure		
0 ... 15 psi	360 psig	0 psi
0 ... 30 psi	360 psig	0 psi
0 ... 150 psi	360 psig	0 psi
0 ... 300 psi	360 psig	0 psi
0 ... 900 psig	360 psig	0 psi

Adjustment ranges

Specifications refer to the nominal measuring range, pressure values lower than -1 bar cannot be set

Level (min./max. adjustment)

- Percentage value -10 ... 110 %
- Pressure value -120 ... 120 %

Flow (min./max. adjustment)

- Percentage value 0 or 100 % fix
- Pressure value -120 ... 120 %

Differential pressure (zero/span adjustment)

- Zero -95 ... +95 %
- Span -120 ... +120 %

Density (min./max. adjustment)

- Percentage value -10 ... 100 %
- Density value according to the measuring ranges in kg/dm³

Interface (min./max. adjustment)

- Percentage value -10 ... 100 %
- Level value according to the measuring ranges in m

Max. permissible Turn Down

Unlimited (recommended 20 : 1)

Dynamic behaviour output

Dynamic characteristics depending on medium and temperature

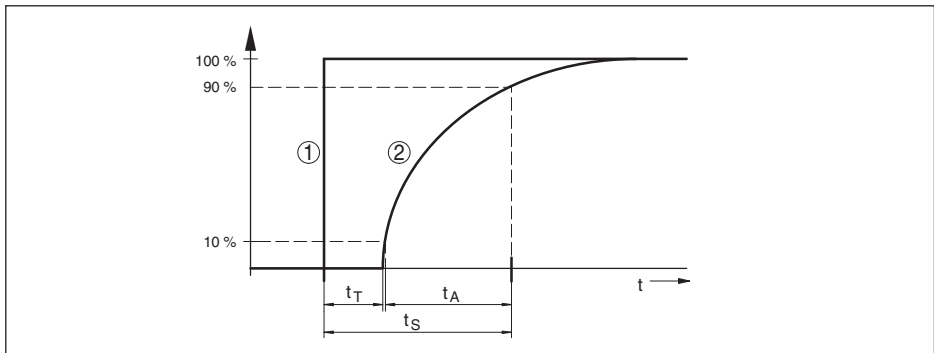

Fig. 22: Behaviour in case of sudden change of the process variable. t_T : dead time; t_A : rise time; t_S : jump response time

- 1 Process variable
- 2 Output signal

- Dead time ≤ 50 ms
- Rise time ≤ 150 ms
- Step response time ≤ 200 ms (t_i : 0 s, 10 ... 90 %)
- Damping (63 % of the input variable) 0 ... 999 s, adjustable via menu item " Damping"

45052-EN-230914

Reference conditions and influencing variables (according to DIN EN 60770-1)

Reference conditions according to DIN EN 61298-1

– Temperature	+15 ... +25 °C (+59 ... +77 °F)
– Relative humidity	45 ... 75 %
– Air pressure	860 ... 1060 mbar/86 ... 106 kPa (12.5 ... 15.4 psig)

Determination of characteristics Limit point adjustment according to IEC 61298-2

Characteristic curve Linear

Reference installation position upright, diaphragm points downward

Influence of the installation position < 0.2 mbar/20 Pa (0.003 psig)

Deviation in the current output due to strong, high-frequency electromagnetic fields acc. to EN 61326-1 < ±150 µA

Deviation (according to IEC 60770-1)

Specifications refer to the set span. Turn down (TD) is the ratio: nominal measuring range/set span.

Accuracy class	Non-linearity, hysteresis and repeatability with TD 1 : 1 up to 5 : 1	Non-linearity, hysteresis and repeatability with 5 : 1
0.1 %	< 0.1 %	< 0.02 % x TD

Influence of the product temperature

Thermal change zero signal and output span

Turn down (TD) is the relation nominal measuring range/adjusted span.

The thermal change of the zero signal and output span corresponds to the value F_T in chapter "Calculation of the total deviation (according to DIN 16086)".

Ceramic measuring cell - Standard

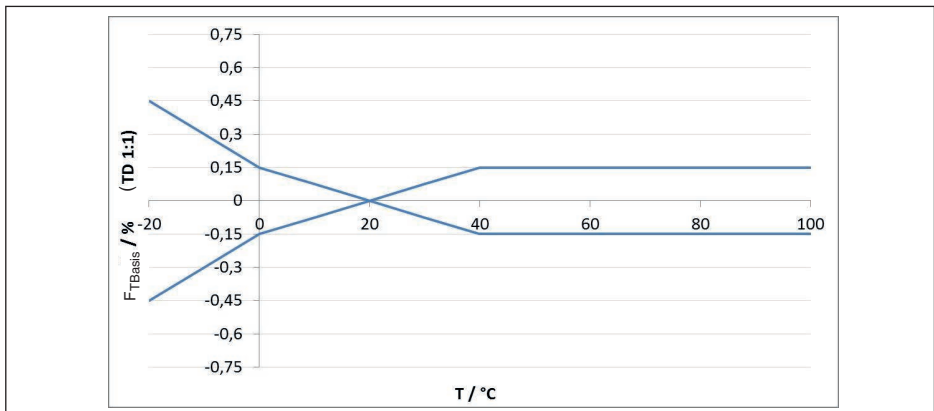

Fig. 23: Basic temperature error F_{TBasis} at TD 1 : 1

The basic temperature error in % from the above graphic can increase due to the additional factors, depending on the measuring cell version (factor FMZ) and the Turn Down (factor FTD). The additional factors are listed in the following tables.

Additional factor through measuring cell version

Measuring cell version	Measuring cell - Standard	
	0.1 %	0.1 % (with measuring range 25 mbar)
Factor FMZ	1	3

Additional factor through Turn Down

The additional factor F_{TD} through Turn down is calculated according to the following formula:

$$F_{TD} = 0.5 \times TD + 0.5$$

In the table, example values for typical Turn downs are listed.

Turn Down	TD 1 : 1	TD 2.5 : 1	TD 5 : 1	TD 10 : 1	TD 20 : 1
Factor FTD	1	1.75	3	5.5	10.5

Long-term stability (according to DIN 16086)

Applies to the respective **digital** signal output (e.g. HART, Profibus PA) as well as to **analogue** current output 4 ... 20 mA under reference conditions. Specifications refer to the set span. Turn down (TD) is the ratio nominal measuring range/set span.

Long-term stability zero signal and output span

Time period	Measuring cell \varnothing 28 mm		Measuring cell \varnothing 17.5 mm
	Measuring ranges from 0 ... +0.1 bar (0 ... +10 kPa)	Measuring range 0 ... +0.025 bar/0 ... +2.5 kPa	
One year	< 0.05 % x TD	< 0.1 % x TD	< 0.1 % x TD
Five years	< 0.1 % x TD	< 0.2 % x TD	< 0.2 % x TD
Ten years	< 0.2 % x TD	< 0.4 % x TD	< 0.4 % x TD

Process conditions

Process temperature

Version	Measuring cell seal	Process temperature
Suspension cable PE	FKM (VP2/A)	-20 ... +60 °C (-4 ... +140 °F)
	EPDM (A+P 70.10-02)	
Suspension cable PUR	FKM (VP2/A)	-20 ... +80 °C (-4 ... +176 °F)
	EPDM (A+P 70.10-02)	
Suspension cable FEP	FKM (VP2/A)	-20 ... +100 °C (-4 ... +212 °F)
	EPDM (A+P 70.10-02)	
	FFKM (Kalrez 6375)	

Version	Measuring cell seal	Process temperature
Connection tube	FKM (VP2/A)	-20 ... +100 °C (-4 ... +212 °F)
	EPDM (A+P 70.10-02)	
	FFKM (Kalrez 6375)	-10 ... +100 °C (+14 ... +212 °F)
Sensor material PVDF	FKM (VP2/A)	-20 ... +60 °C (-4 ... +140 °F)
	EPDM (A+P 70.10-02)	
	FFKM (Kalrez 6375)	-10 ... +60 °C (+14 ... +140 °F)
Sensor protection PE	FKM (VP2/A)	-20 ... +60 °C (-4 ... +140 °F)
	EPDM (A+P 70.10-02)	
Flange GFK/seal ledge PVDF	FKM (VP2/A)	-20 ... +80 °C (-4 ... +176 °F)
	EPDM (A+P 70.10-02)	
	FFKM (Kalrez 6375)	-10 ... +80 °C (+14 ... +176 °F)

Process pressure

Permissible process pressure

see specification " *Process pressure* " on the type label

Mechanical stress⁶⁾

Vibration resistance

– Suspension cable

4 g at 5 ... 200 Hz according to EN 60068-2-6 (vibration with resonance)

– Connection tube

1 g (with lengths > 0.5 m (1.64 ft), the tube must be supported in addition)

Shock resistance

50 g, 2.3 ms according to EN 60068-2-27 (mechanical shock)⁷⁾

Ambient conditions

Version	Ambient temperature	Storage and transport temperature
Version with connection tube	-40 ... +80 °C (-40 ... +176 °F)	-60 ... +80 °C (-76 ... +176 °F)
Version with suspension cable FEP, PUR	-20 ... +80 °C (-4 ... +176 °F)	-20 ... +80 °C (-4 ... +176 °F)
Version with suspension cable PE	-20 ... +60 °C (-4 ... +140 °F)	-20 ... +60 °C (-4 ... +140 °F)
Version IP68 (1 bar) with connection cable PE	-20 ... +60 °C (-4 ... +140 °F)	-20 ... +60 °C (-4 ... +140 °F)

Electromechanical data - version IP66/IP67 and IP66/IP68 (0.2 bar)⁸⁾

Options of the cable entry

– Cable entry

M20 x 1.5; ½ NPT

– Cable gland

M20 x 1.5; ½ NPT (cable diameter see below table)

– Blind plug

M20 x 1.5; ½ NPT

– Closing cap

½ NPT

⁶⁾ Depending on the instrument version

⁷⁾ 2 g with housing version stainless steel double chamber

⁸⁾ IP66/IP68 (0.2 bar), only with absolute pressure.

Material cable gland/Seal insert	Cable diameter		
	5 ... 9 mm	6 ... 12 mm	7 ... 12 mm
PA/NBR	√	√	–
Brass, nickel-plated/NBR	√	√	–
Stainless steel/NBR	–	–	√

Wire cross-section (spring-loaded terminals)

- Massive wire, stranded wire 0.2 ... 2.5 mm² (AWG 24 ... 14)
- Stranded wire with end sleeve 0.2 ... 1.5 mm² (AWG 24 ... 16)

Electromechanical data - version IP68 (25 bar)

Connection cable transmitter - external housing, mechanical data

- Configuration Wires, strain relief, breather capillaries, screen braiding, metal foil, mantle ⁹⁾
- Standard length 5 m (16.40 ft)
- Max. length 180 m (590.5 ft)
- Min. bending radius at 25 °C/77 °F 25 mm (0.985 in)
- Diameter approx. 8 mm (0.315 in)
- Material PE, PUR
- Colour Black, blue

Connection cable transmitter - external housing, electrical data

- Wire cross-section 0.5 mm² (AWG 20)
- Wire resistance 0.037 Ω/m (0.012 Ω/ft)

Interface to the Primary Device

Data transmission Digital (I²C-Bus)

Connection cable Secondary - Primary, mechanical data

- Configuration Cores, strain relief, braided, metal foil, jacket
- Standard length 5 m (16.40 ft)
- Max. length 70 m (229.7 ft)
- Min. bending radius (at 25 °C/77 °F) 25 mm (0.985 in)
- Diameter approx. 8 mm (0.315 in), approx. 6 mm (0.236 in)
- Material PE, PUR
- Colour Black, blue

Connection cable Secondary - Primary, electrical data

- Wire cross-section 0.34 mm² (AWG 22)
- Wire resistance < 0.05 Ω/m (0.015 Ω/ft)

Voltage supply for the complete system through Primary Device

Operating voltage

- U_{B min} 12 V DC

⁹⁾ Breather capillaries not with Ex d version.

- $U_{B \min}$ with lighting switched on 16 V DC
- $U_{B \max}$ Depending on the signal output and version of the Primary Devices

Potential connections and electrical separating measures in the instrument

Electronics	Non-floating
Galvanic separation	
- between electronics and metallic parts of the device	Reference voltage 500 V AC
Conductive connection	Between ground terminal and metallic process fitting

Electrical protective measures ¹⁰⁾

Housing material	Version	Protection acc. to IEC 60529	Protection acc. to NEMA
Plastic	Single chamber	IP66/IP67	Type 4X
Aluminium	Single chamber	IP66/IP67	
		IP66/IP68 (0.2 bar) IP66/IP68 (1 bar)	Type 6P
Stainless steel (electro-polished)	Single chamber	IP66/IP67 IP69K	Type 4X
Stainless steel (precision casting)	Single chamber	IP66/IP67	Type 4X
		IP66/IP68 (0.2 bar) IP66/IP68 (1 bar)	Type 6P
Stainless steel	Transmitter, version with external housing	IP68 (25 bar)	-

Altitude above sea level

- by default up to 2000 m (6562 ft)
- with connected overvoltage protection on the Primary Device up to 5000 m (16404 ft)

Pollution degree ¹¹⁾ 4

Protection rating (IEC 61010-1) II

9.2 Calculation of the total deviation

The total deviation of a pressure transmitter indicates the maximum measurement error to be expected in practice. It is also called maximum practical deviation or operational error.

According to DIN 16086, the total deviation F_{total} is the sum of the basic deviation F_{perf} and the long-term stability F_{stab} :

$$F_{\text{total}} = F_{\text{perf}} + F_{\text{stab}}$$

The basic deviation F_{perf} in turn consists of the thermal change of the zero signal and the output span F_{τ} (temperature error) as well as the deviation F_{KI} :

¹⁰⁾ Protection rating IP66/IP68 (0.2 bar) only in conjunction with absolute pressure, as no air compensation is possible when the sensor is completely flooded

¹¹⁾ When used with fulfilled housing protection.

$$F_{\text{perf}} = \sqrt{((F_T)^2 + (F_{Kl})^2)}$$

The thermal change of zero signal and output span F_T is specified in chapter " *Technical data*". The basic temperature error F_T is shown in a graphic. Depending on the measuring cell version and Turn down, this value must be multiplied with the additional factors FMZ and FTD:

$$F_T \times \text{FMZ} \times \text{FTD}$$

Also these values are specified in chapter " *Technical data*".

This applies initially to the digital signal output through HART, Profibus PA, Foundation Fieldbus or Modbus.

With 4 ... 20 mA output, the thermal change of the current output F_a must be added:

$$F_{\text{perf}} = \sqrt{((F_T)^2 + (F_{Kl})^2 + (F_a)^2)}$$

To provide a better overview, the formula symbols are listed together below:

- F_{total} : Total deviation
- F_{perf} : Basic deviation
- F_{stab} : Long-term stability
- F_T : Thermal change of zero signal and output span (temperature error)
- F_{Kl} : Deviation
- F_a : Thermal change of the current output
- FMZ: Additional factor measuring cell version
- FTD: Additional factor Turn down

9.3 Practical example

Data

Measurement of the level difference in two water reservoirs, 1,600 mm height corresponds to 0.157 bar (157 kPa), medium temperature 50 °C

VEGABAR 86 with measuring range 0.4 bar, deviation < 0.1 %, meas. cell ø 28 mm

1. Calculation of the Turn down

$$\text{TD} = 0.4 \text{ bar} / 0.157 \text{ bar}, \text{TD} = \mathbf{2.6 : 1}$$

2. Determination temperature error F_T

The necessary values are taken from the technical data:

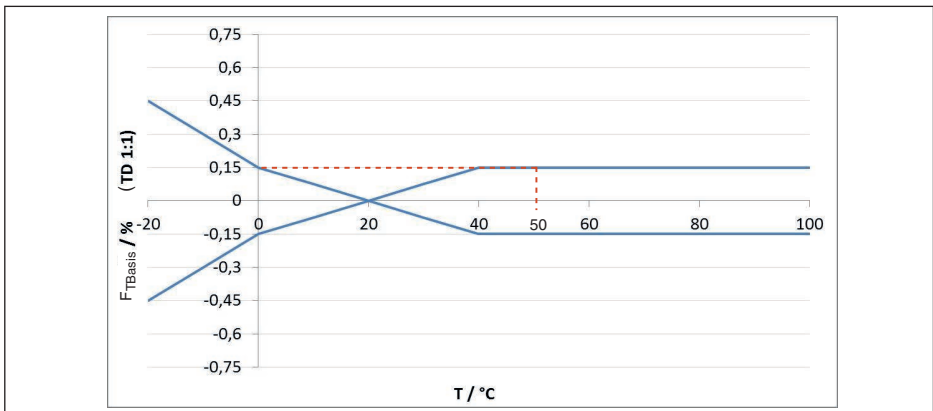

Fig. 24: Determination of the basic temperature error for the above example: $F_{T\text{basis}} = \mathbf{0.15\%}$

Measuring cell version	Measuring cell - Standard	Measuring cell climate-compensated, depending on measuring range		
	0.1 %	10 bar, 25 bar	1 bar, 2.5 bar	0.4 bar
Factor FMZ	1	1	2	3

Tab. 17: Determination of the additional factor measuring cell for above example: $F_{Mz} = 1$

Turn Down	TD 1 : 1	TD 2.5 : 1	TD 5 : 1	TD 10 : 1	TD 20 : 1
Factor FTD	1	1.75	3	5.5	10.5

Tab. 18: Determination of the additional factor "turn down" for the above example: $F_{TD} = 1.75$

$$F_T = F_{TBasis} \times F_{Mz} \times F_{TD}$$

$$F_T = 0.15 \% \times 1 \times 1.75$$

$$F_T = 0.26 \%$$

3. Determination of deviation and long-term stability

The required values for deviation F_{ki} and long-term stability F_{stab} are available in the technical data:

Accuracy class	Non-linearity, hysteresis and non-repeatability	
	TD ≤ 5 : 1	TD > 5 : 1
0.1 %	< 0.1 %	< 0.02 % x TD

Tab. 19: Determination of the deviation from table: $F_{ki} = 0.1 \%$

VEGABAR 86

Time period	Measuring cell ø 28 mm		Measuring cell ø 17.5 mm
	All measuring ranges	Measuring range 0 ... +0.025 bar/0 ... +2.5 kPa	
One year	< 0.05 % x TD	< 0.1 % x TD	< 0.1 % x TD
Five years	< 0.1 % x TD	< 0.2 % x TD	< 0.2 % x TD
Ten years	< 0.2 % x TD	< 0.4 % x TD	< 0.4 % x TD

VEGABAR 87

Time period	All measuring ranges	Measuring range 0 ... +0.025 bar/0 ... +2.5 kPa
One year	< 0.05 % x TD	< 0.1 % x TD
Five years	< 0.1 % x TD	< 0.2 % x TD
Ten years	< 0.2 % x TD	< 0.4 % x TD

Tab. 20: Determination of the long-term stability from the table, consideration for one year: $F_{stab} = 0.05 \% \times TD = 0.05 \% \times 2.6 = 0.13 \%$

4. Calculation of the total deviation - digital signal

- 1. step: Basic accuracy F_{perf}

$$F_{perf} = \sqrt{((F_T)^2 + (F_{ki})^2)}$$

$$F_T = 0.26 \%$$

$$F_{Kl} = 0.1 \%$$

$$F_{perf} = \sqrt{(0.26 \%)^2 + (0.1 \%)^2}$$

$$F_{perf} = 0.28 \%$$

- 2. step: Total deviation F_{total}

$$F_{total} = F_{perf} + F_{stab}$$

$$F_{perf} = 0.28 \%$$
 (result of step 1)

$$F_{stab} = (0.05 \% \times TD)$$

$$F_{stab} = (0.05 \% \times 2.5)$$

$$F_{stab} = 0.13 \%$$

$$F_{total} = 0.28 \% + 0.13 \% = 0.41 \%$$

5. Calculation of the total deviation of the measuring system

Both sensors are included in the calculation of the total deviation of the measuring system. With the 4 ... 20 mA Primary Device the thermal error of the analogue output is also added:

$$F_{total} = \sqrt{(F_{total-Primary})^2 + (F_{total-Secondary})^2 + (F_a)^2}$$

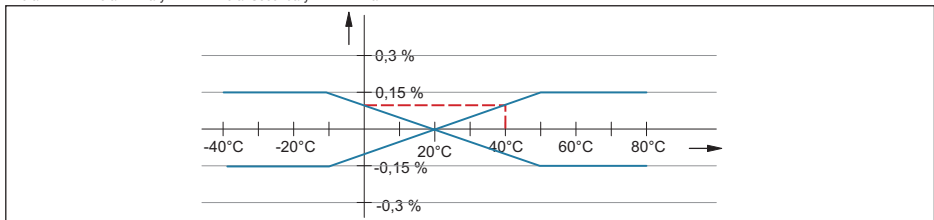

Fig. 25: F_a through thermal change current output, in this example = 0.1 %

$$F_{total} = \sqrt{(0.41 \%)^2 + (0.41 \%)^2 + (0.1 \%)^2} = 0.59 \%$$

The total deviation of the measuring system is hence 0.59 %.

Deviation in mm: 0.59 % of 1,600 mm = 9 mm

The example shows that the measurement error in practice can be considerably higher than the basic accuracy. Reasons are temperature influence and Turn down.

The thermal change of the current output is in this example is negligible.

9.4 Dimensions

The following dimensional drawings represent only an extract of the possible versions. Detailed dimensional drawings can be downloaded at www.vega.com under "Downloads" and "Drawings".

Housing

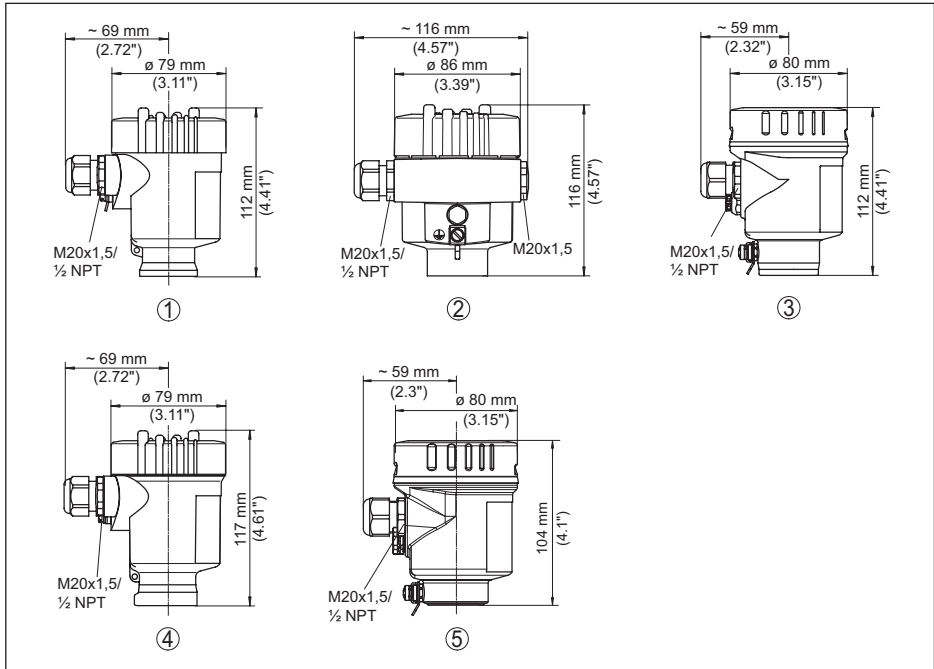

Fig. 26: Housing versions in protection rating IP66/IP67 and IP66/IP68 (0.2 bar), (with integrated display and adjustment module the housing is 9 mm/0.35 in or 18 mm/0.71 in higher)

- 1 Plastic single chamber (IP66/IP67)
- 2 Aluminium - single chamber
- 3 Stainless steel single chamber (electropolished)
- 4 Stainless steel single chamber (precision casting)
- 5 Stainless steel single chamber (electropolished) IP69K

External housing on IP68 version

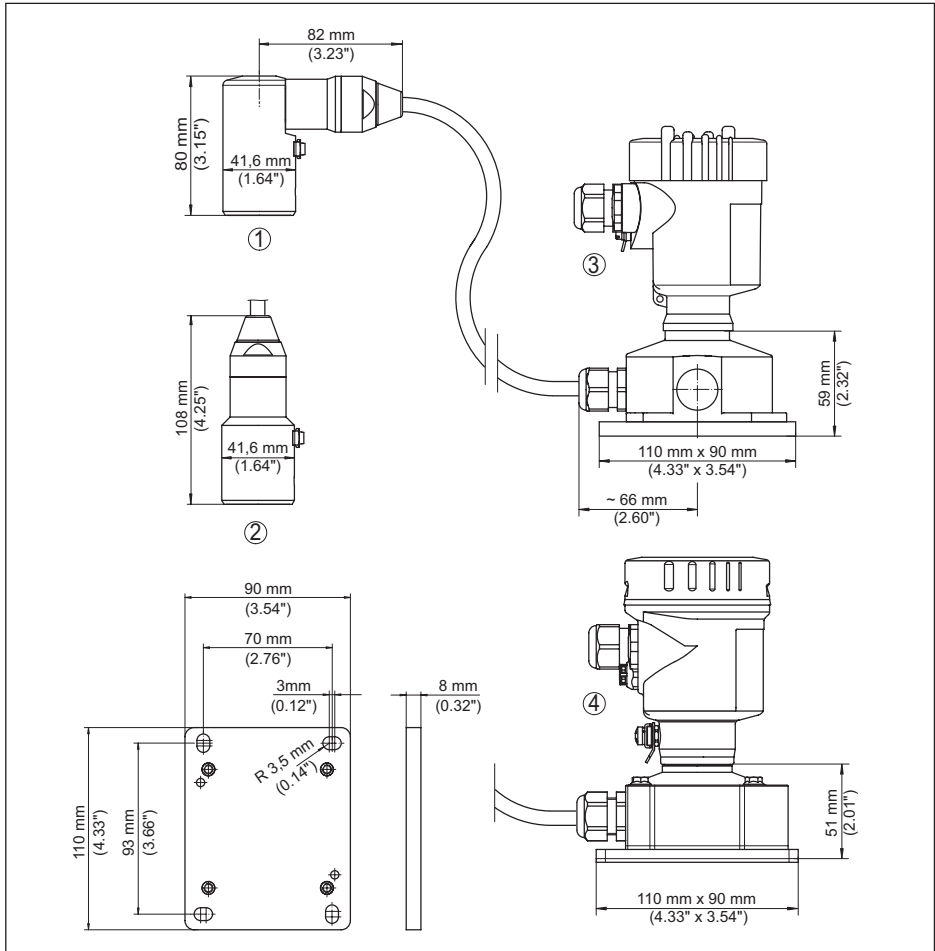

Fig. 27: VEGABAR 86, IP68 version with external housing

- 1 Lateral cable outlet
- 2 Axial cable outlet
- 3 Plastic single chamber
- 4 Stainless steel single chamber
- 5 Seal 2 mm (0.079 in), (only with 3A approval)

VEGABAR 86, sensor (32 mm)

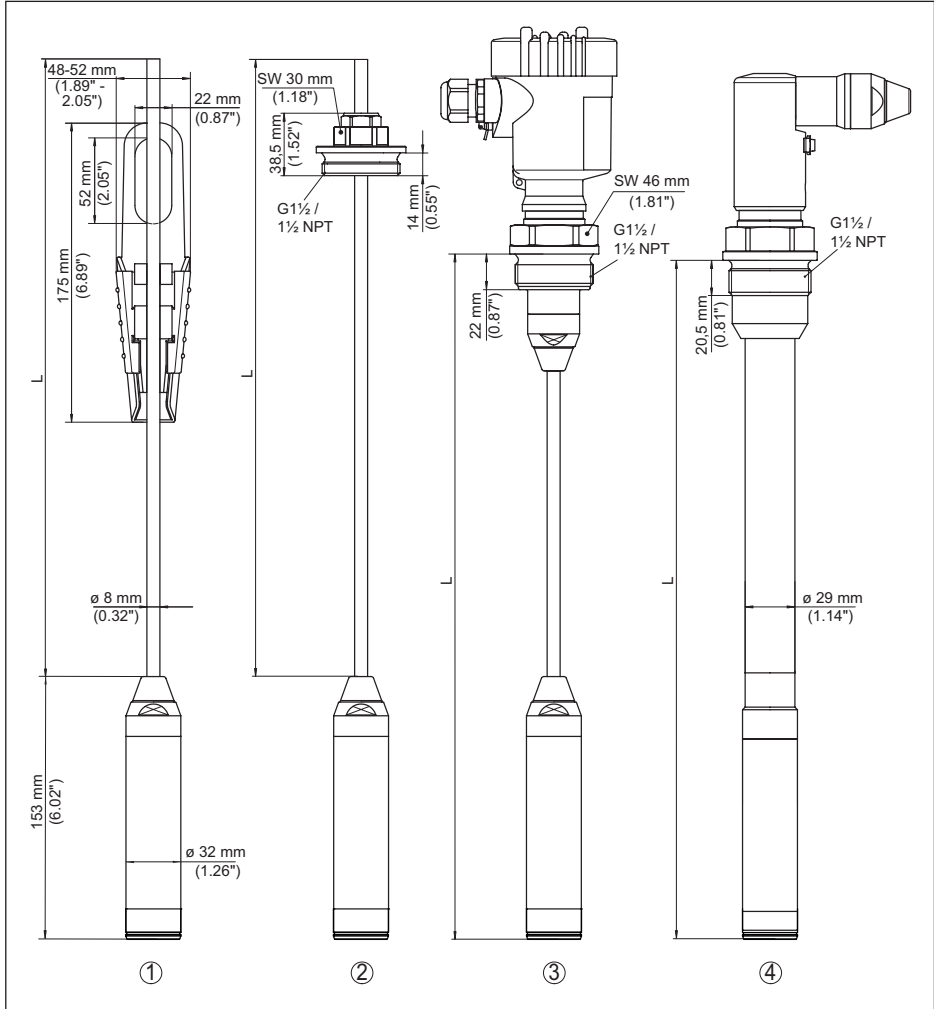

Fig. 28: VEGABAR 86, sensor (32 mm)

- 1 Straining clamp
- 2 Adjustable suspension cable gland G1½, 1½ NPT
- 3 Thread G1½, 1½ NPT
- 4 Cable outlet with thread G1½, 1½ NPT
- L Total length from configurator

VEGABAR 86, sensor (22 mm)

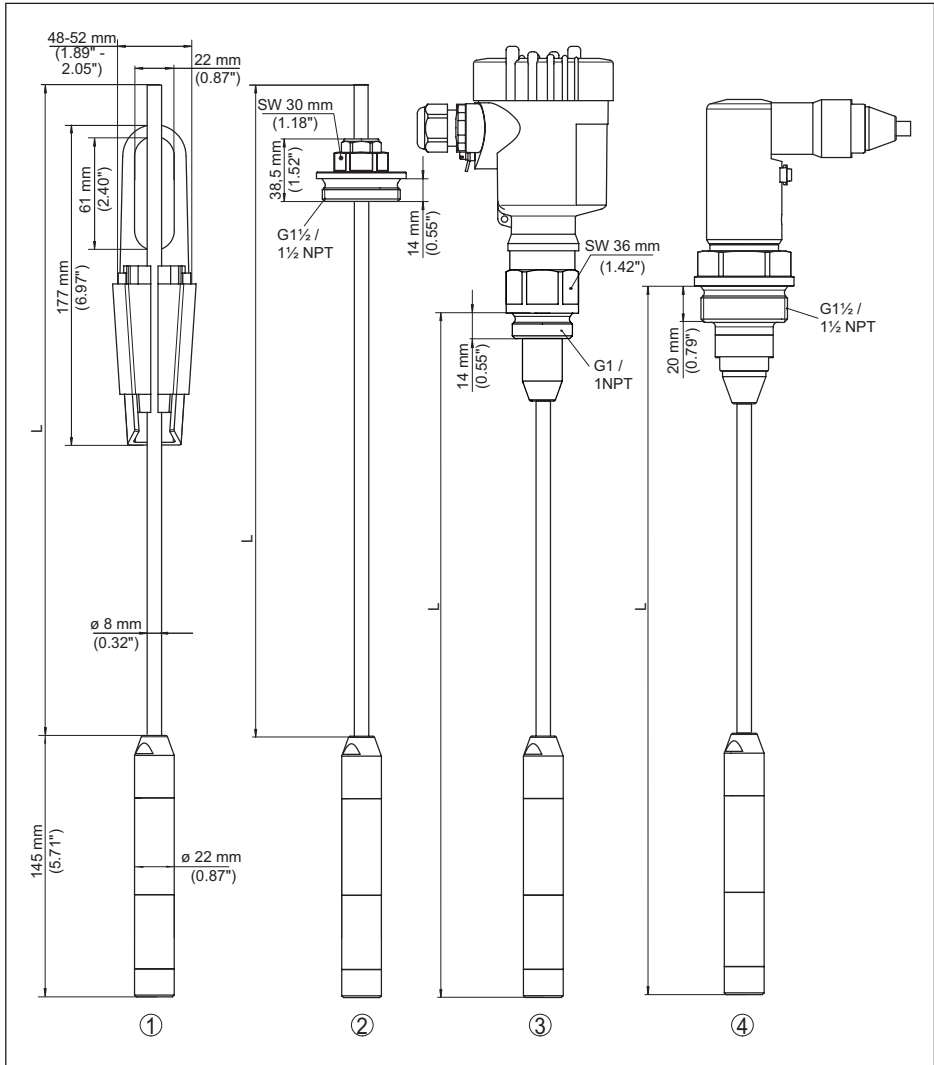

Fig. 29: VEGABAR 86, sensor (22 mm)

- 1 Straining clamp
- 2 Adjustable suspension cable gland G1½, 1½ NPT
- 3 Thread G1, 1 NPT
- 4 Cable outlet with thread G1½, 1½ NPT
- L Total length from configurator

VEGABAR 86, plastic version

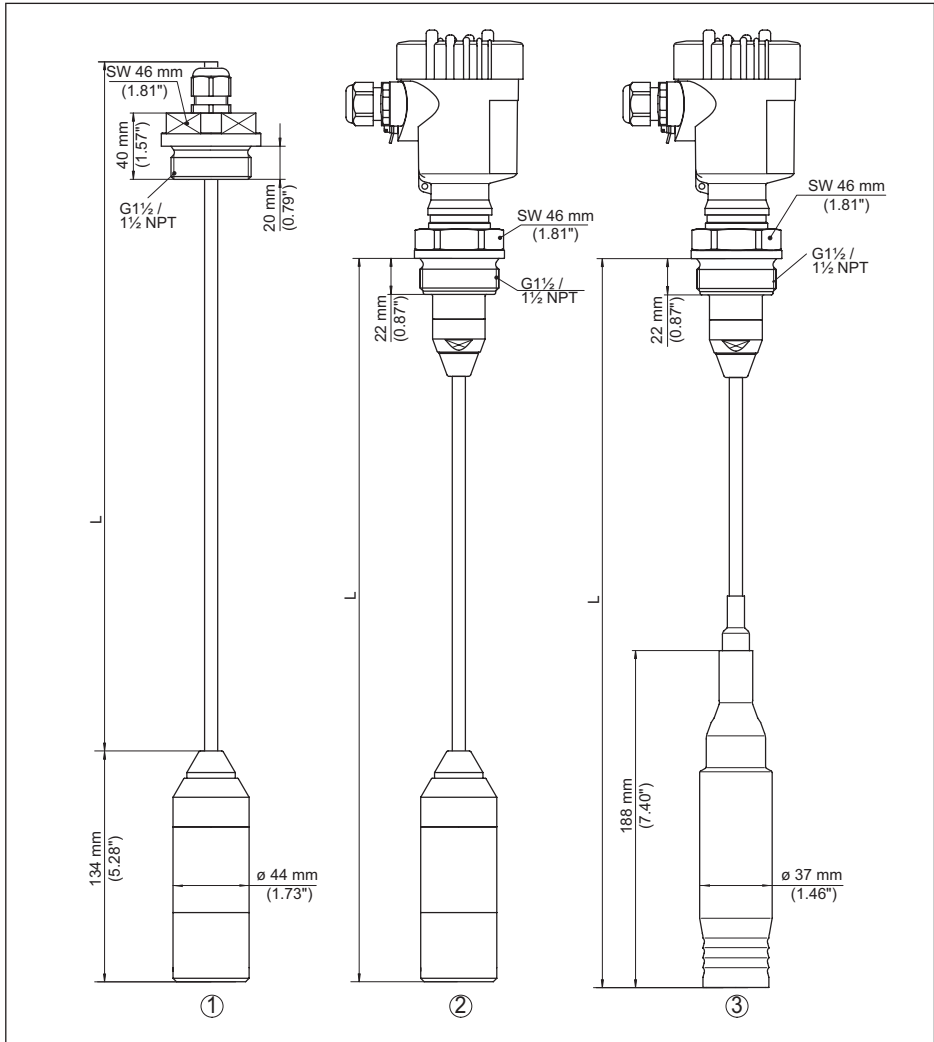

Fig. 30: VEGABAR 86, plastic version

- 1 PVDF, with threaded fitting G1½, 1½ NPT
 - 2 PVDF, with thread G1½, 1½ NPT
 - 3 PE coated, with thread G1½, 1½ NPT
- L Total length from configurator

VEGABAR 86, flange connection

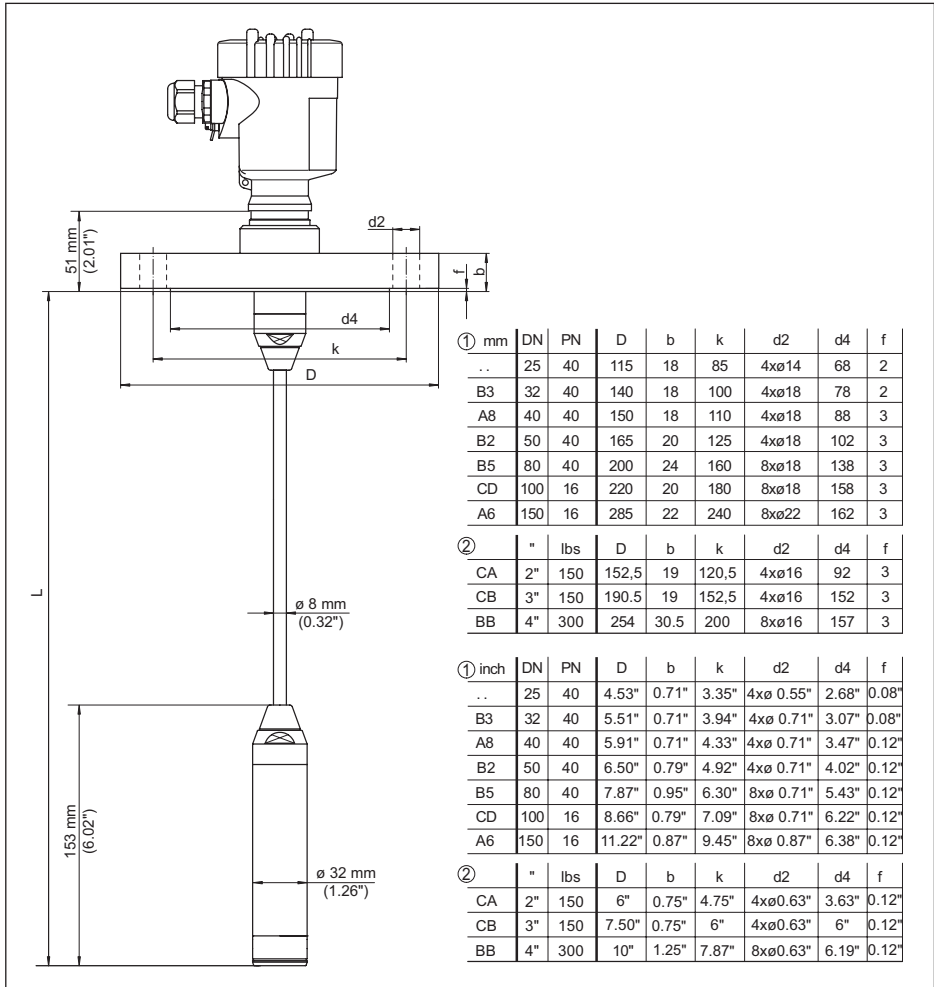

Fig. 31: VEGABAR 86, flange connection (example: sensor 32 mm)

- 1 Flanges according to DIN 2501
- 2 Flanges according to ASME B16.5
- L Total length from configurator

VEGABAR 86, hygienic fitting

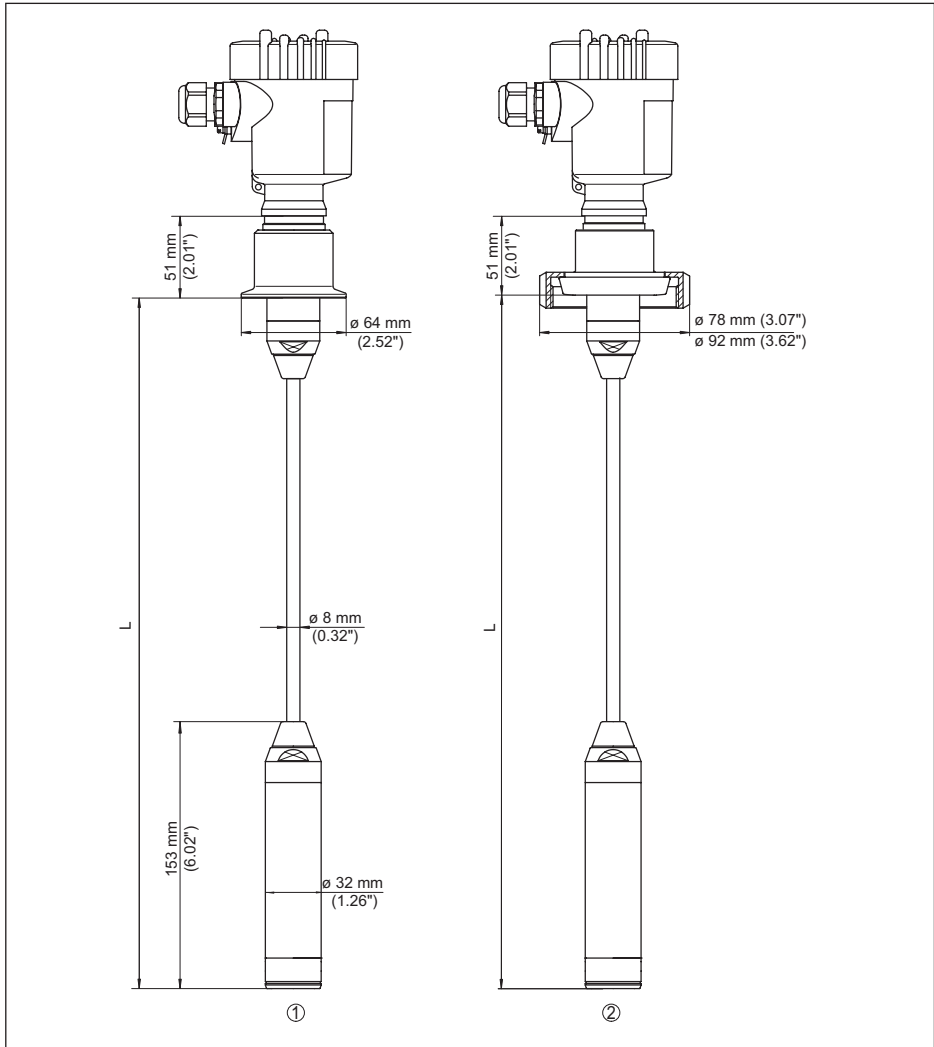

Fig. 32: VEGABAR 86, hygienic fittings

- 1 Clamp 2" PN 16 ($\varnothing 64$ mm), (DIN 32676, ISO 2852)
 2 Slotted nut DN 50
 L Total length from configurator

VEGABAR 86, threaded version

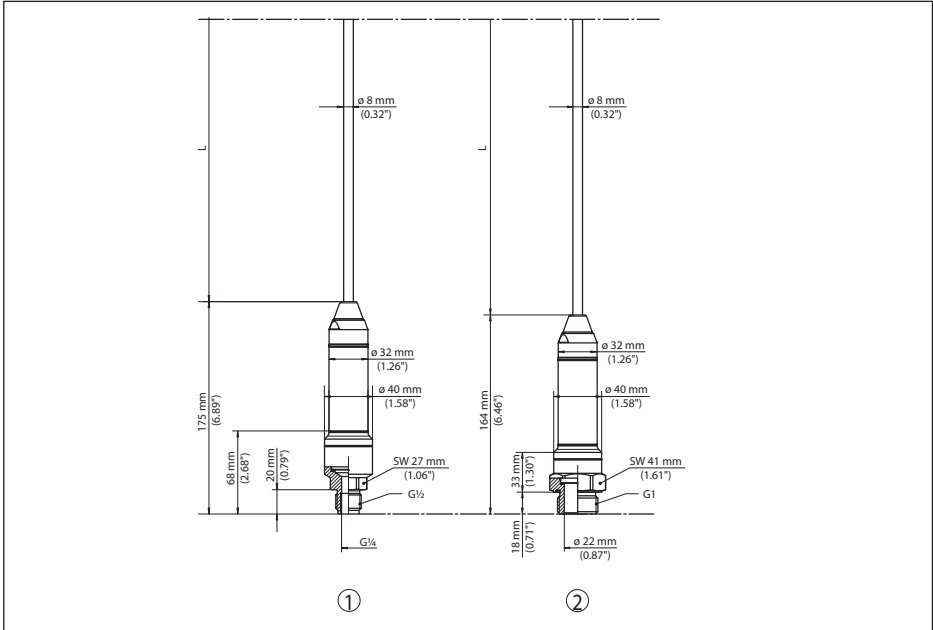

Fig. 33: VEGABAR 86, threaded version

- 1 Thread G $\frac{1}{2}$, internal G $\frac{1}{4}$
- 2 Thread $\frac{1}{2}$ NPT, hole \varnothing 11 mm
- 3 Thread G1
- L Total length from configurator

9.5 Industrial property rights

VEGA product lines are global protected by industrial property rights. Further information see www.vega.com.

VEGA Produktfamilien sind weltweit geschützt durch gewerbliche Schutzrechte.

Nähere Informationen unter www.vega.com.

Les lignes de produits VEGA sont globalement protégées par des droits de propriété intellectuelle. Pour plus d'informations, on pourra se référer au site www.vega.com.

VEGA líneas de productos están protegidas por los derechos en el campo de la propiedad industrial. Para mayor información revise la pagina web www.vega.com.

Линии продукции фирмы ВЕГА защищаются по всему миру правами на интеллектуальную собственность. Дальнейшую информацию смотрите на сайте www.vega.com.

VEGA系列产品在全球享有知识产权保护。

进一步信息请参见网站 < www.vega.com。

9.6 Trademark

All the brands as well as trade and company names used are property of their lawful proprietor/originator.

INDEX**A**

- Adjustment 30, 31, 32, 33, 34
 - Level 35
 - Overview 29
 - Unit 28

AI FB1 Function Block 36

C

- Channel 36
- Characteristic values of the differential pressure transmitter 39
- Connection
 - Steps 22
 - Technology 22
- Current output 38

D

Documentation 7

E

Electrical connection 21

F

Fault rectification 42

G

Gas-tight leadthrough (Second Line of Defense)
14

L

Linearisation 36

M

- Maintenance 42
- Measurement setup
 - Density measurement 17
 - Interface measurement 16
 - Level difference measurement 16
 - Level measurement 18

P

- Peak indicator 37
- Position correction 28
- Pressure compensation 14
 - Second Line of Defense 14
 - Standard 14

Q

QR code 7

R

Repair 44

S

- Seal concept 9
- Serial number 7
- Service hotline 42
- Set display parameters 37
- Simulation 37, 38

T

Type label 7

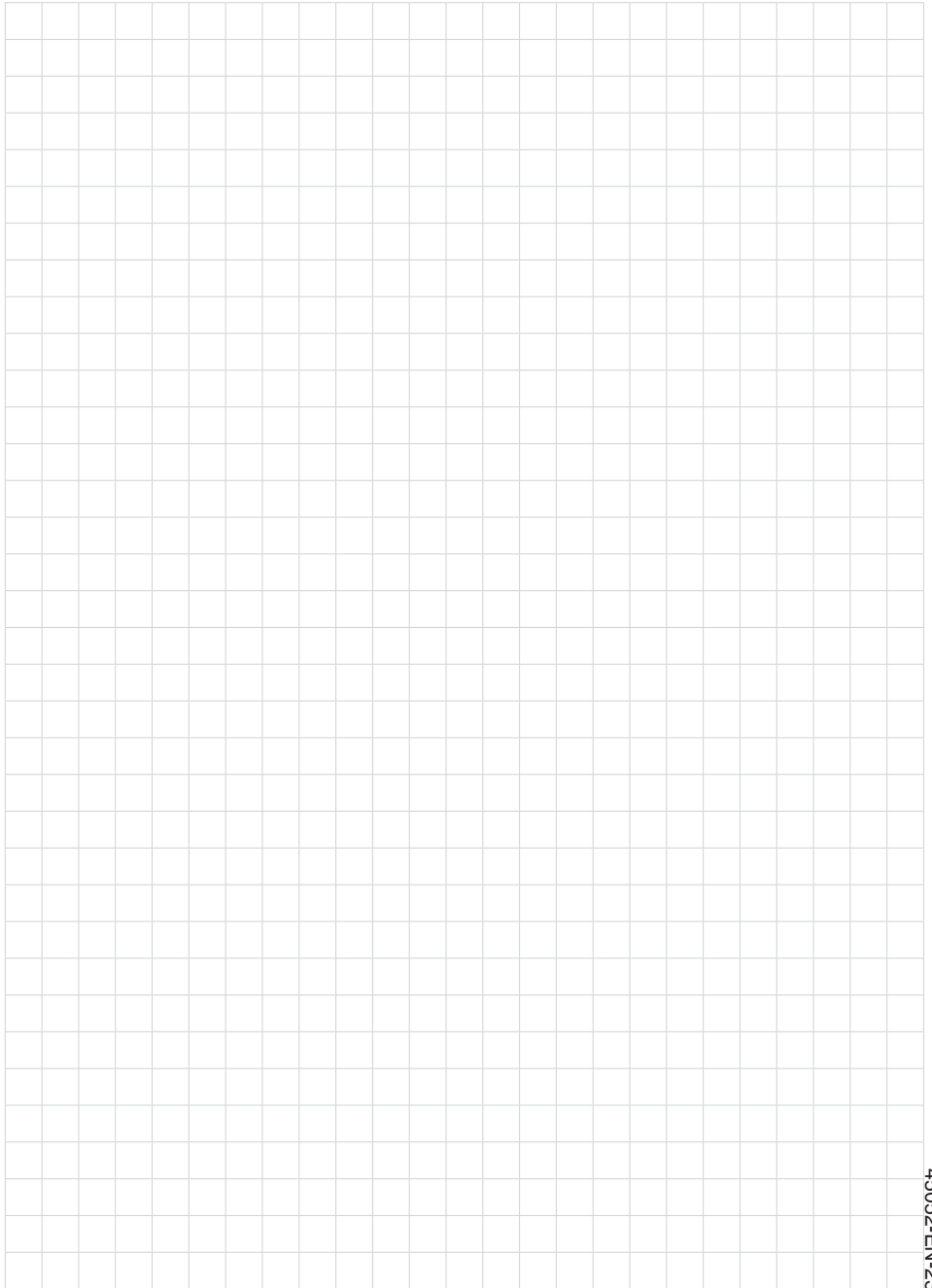

45052-EN-230914

A large grid of graph paper for taking notes, consisting of 20 columns and 30 rows of small squares.



Printing date:

VEGA

All statements concerning scope of delivery, application, practical use and operating conditions of the sensors and processing systems correspond to the information available at the time of printing.

Subject to change without prior notice

© VEGA Grieshaber KG, Schiltach/Germany 2023



45052-EN-230914

VEGA Grieshaber KG
Am Hohenstein 113
77761 Schiltach
Germany

Phone +49 7836 50-0
E-mail: info.de@vega.com
www.vega.com