

# POINTRAC 31

Profibus PA

Radiometric sensor for level detection



### Application area

The POINTRAC 31 is a radiometric sensor for universal level detection of liquids and bulk solids. Independent of the mounting location, it monitors reliably the limit level in vessels. The sensor can be used for applications in all industries. Due to the high sensitivity POINTRAC 31 is an economical solution with minimum radiation activity.

### Your benefit

- Exact measuring results independent of process conditions
- High process reliability through determination of buildup
- Economical level detection under arduous application conditions

### Function

In radiometric measurement, a Caesium-137 or Cobalt-60 isotope emits focussed gamma rays. A special sensor on the opposite side of the vessel receives this radiation. The scintillator of the sensor converts these gamma rays into signals, the number of which is detected and evaluated. Since gamma rays are attenuated when penetrating matter, the sensor is able to calculate the level, the limit level, the density and the mass flow rate from the intensity of the received radiation.

### Technical data

Measuring range	45 mm (1.8 in), 152 mm (6 in) or 304 mm (12 in)
Non-repeatability	±0.5 % at -40 °C ... +60 °C (-40 °F ... +140 °F)
Ambient, storage and transport temperature	-40 °C ... +60 °C (-40 °F ... +140 °F) Extended range available

### Voltage supply

Operating voltage	20 ... 72 V DC; 20 ... 253 V AC, 50/60 Hz
Max. power consumption	4 W; 6 VA

### Analogue input

Input type	4 ... 20 mA passive
Internal load	250 Ω

### Switching input

Input type	
– Open Collector	10 mA
– Relay contact	100 mA

### Relay output

Switching voltage	max. 253 V AC/DC
Switching current	max. 3 A AC (cos phi > 0.9), 1 A DC
Breaking capacity	min. 50 mW, max. 750 VA AC, 40 W DC (with U < 40 V DC)

### Digital PA output

Output signal	digital output signal, format according to IEEE-754
Sensor address	126 (default setting)

### Switching output

Type of output	NPN transistor output (floating)
Switching voltage	< 55 V DC
Load current	< 400 mA

### General data

SIL qualification	Optionally up to SIL2
-------------------	-----------------------

### Materials/Scintillator

The detector tube consists of stainless steel. Polyvinyltoluene (PVT) is used as scintillation material.

### Housing versions

The housing is available as double chamber version of Aluminium or stainless steel in protection class IP66/IP67.

### Electronics versions

As electronics version, an 8/16 mA/HART output and digital outputs with Profibus PA and Foundation Fieldbus are possible.

### Approvals

Worldwide approvals are available for VEGA instruments, e.g. for use in hazardous areas, on ships or in hygienic applications.

The technical data in the respective safety instructions are valid for approved instruments (e.g. with Ex approval). In some cases, these data can differ from the data listed herein.

You can find detailed information on the existing approvals with the appropriate product on our homepage.

## Adjustment

### Adjustment directly at the measuring point

The adjustment of the instrument is carried out via the optional display and adjustment module PLICSCOM or via a PC with the adjustment software PACTware and corresponding DTM.

### Wireless adjustment via Bluetooth

The Bluetooth version of display and adjustment module enables a wireless connection to standard adjustment units. This can be smartphones/tablets with iOS or Android operating system or PCs with PACTware and Bluetooth USB adapter.



Wireless connection to standard operating devices

Adjustment is hence carried out via a free-of-charge app from the Apple App Store or the Google Play Store or via the adjustment software PACTware and respective DTM.

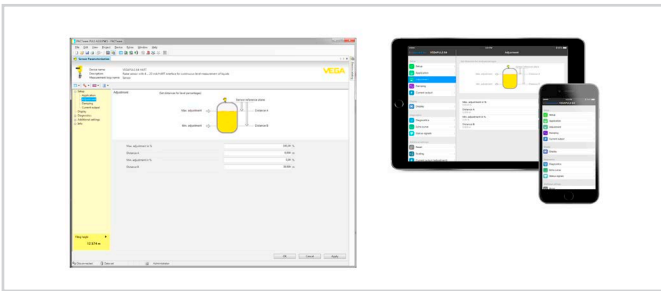

Adjustment via PACTware or app

### Adjustment via remote systems

Further adjustment options are possible via a HART Communicator as well as manufacturer-specific programs such as AMS<sup>†</sup> or PDM.

## Electrical connection

Two connection chambers are available. Depending on the instrument version, the signal output is either in the primary or in the secondary chamber.

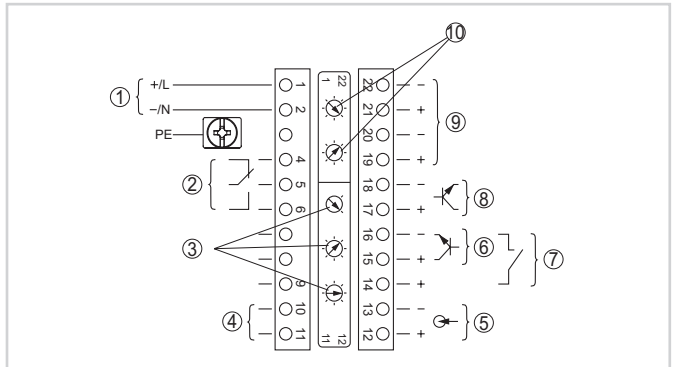

Primary terminal connections

- 1 Voltage supply
- 2 Relay output
- 3 Adjustment bus address for Profibus PA
- 4 Connection Profibus PA
- 5 Signal input 4 ... 20 mA (active sensor)
- 6 Switching input for NPN transistor
- 7 Switching input floating
- 8 Transistor output
- 9 Interface for sensor-sensor communication (MGC)
- 10 Setting the bus address for sensor-sensor communication (MGC)

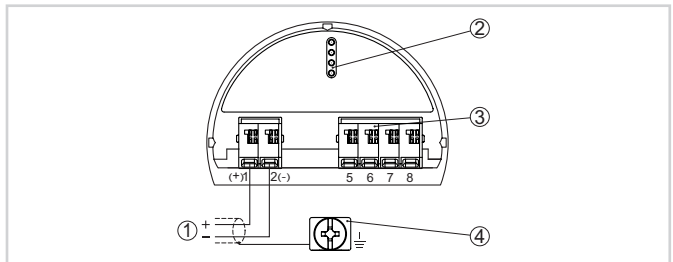

Secondary terminal connections (intrinsically safe devices)

- 1 Terminals for Profibus PA
- 2 Contact pins for the display and adjustment module or interface adapter
- 3 Terminals for external display and adjustment unit
- 4 Ground terminal

## Specification sheet

### Dimensions

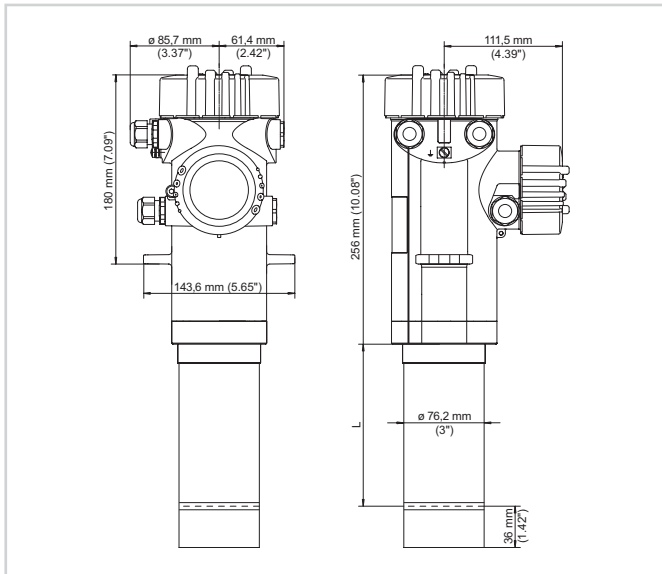

Dimensions POINTRAC 31

### Information

You can find further information on the VEGA product line on our homepage.

In the download section on our homepage you'll find operating instructions, product information, brochures, approval documents, instrument drawings and much, much more.

Software accessories such as the current device software and the appropriate operating software are also available there.

### Instrument selection

On our homepage under "*Products*" you can select the suitable measuring principle and instrument for your application.

There you will also find detailed information on the available device versions.

### Contact

You can find your personal contact person at VEGA on our homepage under "*Contact*".