

Operating Instructions

VEGAMIP R61

Receiving unit

Transistor



Document ID: 40694



VEGA

Contents

1	About this document	4
1.1	Function	4
1.2	Target group	4
1.3	Symbols used.....	4
2	For your safety	5
2.1	Authorised personnel	5
2.2	Appropriate use.....	5
2.3	Warning about incorrect use.....	5
2.4	General safety instructions	5
2.5	Conformity.....	6
2.6	Radio license for Europe	6
2.7	Radio license for USA/Canada.....	6
2.8	Installation and operation in the USA and Canada	6
2.9	Environmental instructions	7
3	Product description	8
3.1	Configuration.....	8
3.2	Principle of operation.....	8
3.3	Packaging, transport and storage.....	10
3.4	Accessories.....	10
4	Mounting	12
4.1	General instructions	12
4.2	Mounting instructions	13
5	Connecting to power supply	24
5.1	Preparing the connection	24
5.2	Connection procedure.....	25
5.3	Wiring plan, single chamber housing.....	26
6	Setup	28
6.1	Adjustment system	28
6.2	Adjustment	29
7	Maintenance and fault rectification	34
7.1	Maintenance	34
7.2	Rectify faults.....	34
7.3	Exchanging the electronics	35
7.4	How to proceed if a repair is necessary.....	35
8	Dismount	36
8.1	Dismounting steps.....	36
8.2	Disposal	36
9	Supplement	37
9.1	Technical data	37
9.2	Dimensions	41
9.3	Industrial property rights.....	44
9.4	Trademark.....	44

**Safety instructions for Ex areas:**

Take note of the Ex specific safety instructions for Ex applications. These instructions are attached as documents to each instrument with Ex approval and are part of the operating instructions.

Editing status: 2022-10-12

1 About this document

1.1 Function

This instruction provides all the information you need for mounting, connection and setup as well as important instructions for maintenance, fault rectification, the exchange of parts and the safety of the user. Please read this information before putting the instrument into operation and keep this manual accessible in the immediate vicinity of the device.

1.2 Target group

This operating instructions manual is directed to trained personnel. The contents of this manual must be made available to the qualified personnel and implemented.

1.3 Symbols used



Document ID

This symbol on the front page of this instruction refers to the Document ID. By entering the Document ID on www.vega.com you will reach the document download.



Information, note, tip: This symbol indicates helpful additional information and tips for successful work.



Note: This symbol indicates notes to prevent failures, malfunctions, damage to devices or plants.



Caution: Non-observance of the information marked with this symbol may result in personal injury.



Warning: Non-observance of the information marked with this symbol may result in serious or fatal personal injury.



Danger: Non-observance of the information marked with this symbol results in serious or fatal personal injury.



Ex applications

This symbol indicates special instructions for Ex applications.



List

The dot set in front indicates a list with no implied sequence.



Sequence of actions

Numbers set in front indicate successive steps in a procedure.



Disposal

This symbol indicates special instructions for disposal.

2 For your safety

2.1 Authorised personnel

All operations described in this documentation must be carried out only by trained, qualified personnel authorised by the plant operator.

During work on and with the device, the required personal protective equipment must always be worn.

2.2 Appropriate use

The VEGAMIP 61 is a sensor for point level detection.

You can find detailed information about the area of application in chapter " *Product description*".

Operational reliability is ensured only if the instrument is properly used according to the specifications in the operating instructions manual as well as possible supplementary instructions.

2.3 Warning about incorrect use

Inappropriate or incorrect use of this product can give rise to application-specific hazards, e.g. vessel overflow through incorrect mounting or adjustment. Damage to property and persons or environmental contamination can result. Also, the protective characteristics of the instrument can be impaired.

2.4 General safety instructions

This is a state-of-the-art instrument complying with all prevailing regulations and directives. The instrument must only be operated in a technically flawless and reliable condition. The operator is responsible for the trouble-free operation of the instrument. When measuring aggressive or corrosive media that can cause a dangerous situation if the instrument malfunctions, the operator has to implement suitable measures to make sure the instrument is functioning properly.

The safety instructions in this operating instructions manual, the national installation standards as well as the valid safety regulations and accident prevention rules must be observed by the user.

For safety and warranty reasons, any invasive work on the device beyond that described in the operating instructions manual may be carried out only by personnel authorised by the manufacturer. Arbitrary conversions or modifications are explicitly forbidden. For safety reasons, only the accessory specified by the manufacturer must be used.

To avoid any danger, the safety approval markings and safety tips on the device must also be observed.

The emitting frequencies of the sensors depend on the model, but are all in the K band range. The low transmitting power lies far below the internationally permitted limit value. When the instrument is used correctly, it presents no danger to human health. It may be operated without restriction outside of closed vessels.

2.5 Conformity

The device complies with the legal requirements of the applicable country-specific directives or technical regulations. We confirm conformity with the corresponding labelling.

The corresponding conformity declarations can be found on our homepage.

Electromagnetic compatibility

Instruments in four-wire or Ex-d-ia version are designed for use in an industrial environment. Nevertheless, electromagnetic interference from electrical conductors and radiated emissions must be taken into account, as is usual with class A instruments according to EN 61326-1. If the instrument is used in a different environment, the electromagnetic compatibility to other instruments must be ensured by suitable measures.

2.6 Radio license for Europe

The instrument was tested according to the latest issue of the following harmonized standards:

EN 300440-1 - Short Range Devices (SRD)

2.7 Radio license for USA/Canada

Operation is only permitted if the following two conditions are fulfilled:

- The instrument must not emit interference radiation
- The instrument must operate without being affected by incoming interference radiation, including such that may trigger unwanted operating conditions.

The instrument is in conformity with the following regulations:

FCC: Part 15 of the FCC regulations

IC: RSS-210 Issue 7, RSS-GEN Issue 2 and RSS-102 Issue 4 of the IC regulations.

Conversions or modifications of the instrument not expressly approved by the manufacturer will lead to loss of the approval.

Before use, make sure that the respective approval numbers are stated on the type label (see chapter " *Configuration* ").

2.8 Installation and operation in the USA and Canada

This information is only valid for USA and Canada. Hence the following text is only available in the English language.

Installations in the US shall comply with the relevant requirements of the National Electrical Code (ANSI/NFPA 70).

Installations in Canada shall comply with the relevant requirements of the Canadian Electrical Code.

2.9 Environmental instructions

Protection of the environment is one of our most important duties. That is why we have introduced an environment management system with the goal of continuously improving company environmental protection. The environment management system is certified according to DIN EN ISO 14001.

Please help us fulfil this obligation by observing the environmental instructions in this manual:

- Chapter "*Packaging, transport and storage*"
- Chapter "*Disposal*"

3 Product description

3.1 Configuration

Type label

The type label contains the most important data for identification and use of the instrument:

- Article number
- Serial number
- Technical data
- ID numbers, instrument documentation

Serial number - Instrument search

The type label contains the serial number of the instrument. With it you can find the following instrument data on our homepage:

- Product code (HTML)
- Delivery date (HTML)
- Order-specific instrument features (HTML)
- Operating instructions and quick setup guide at the time of shipment (PDF)
- Test certificate (PDF) - optional

Move to "www.vega.com" and enter in the search field the serial number of your instrument.

Alternatively, you can access the data via your smartphone:

- Download the VEGA Tools app from the "*Apple App Store*" or the "*Google Play Store*"
- Scan the QR-code on the type label of the device or
- Enter the serial number manually in the app

Scope of delivery

The scope of delivery encompasses:

- Point level sensor VEGAMIP R61 (receiving unit)

The further scope of delivery encompasses:

- Documentation
 - Operating instructions VEGAMIP 61
 - Instructions for optional instrument features
 - Ex-specific "*Safety instructions*" (with Ex versions)
 - If necessary, further certificates

The corresponding emitting unit VEGAMIP T61 is described in a separate operating instructions manual.

3.2 Principle of operation

Application area

VEGAMIP 61 is a microwave barrier for level detection.

It is designed for industrial use in all areas of process technology and can be used in bulk solids and liquids.

Typical applications are overfill and dry run protection. With an operating distance of 100 m, VEGAMIP 61 can be used, for example, in bulk solids silos with large diameters. Thanks to its simple and rugged measuring system, VEGAMIP 61 is virtually unaffected by the process and the chemical and physical properties of the medium.

VEGAMIP 61 can also be used for detection of vehicles and ships or for material recognition on conveyor belts.

It works even under extremely difficult conditions: different grain sizes, contamination, extreme filling noise, high temperatures, strong dust generation and abrasive products are all no problem for the instrument.

The VEGAMIP 61 consists of the components:

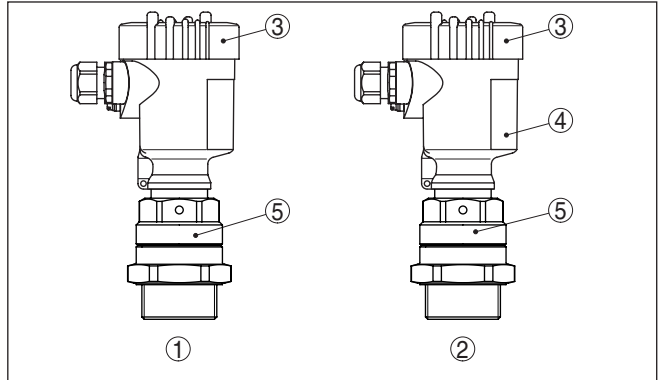

Fig. 1: VEGAMIP 61 with plastic housing

- 1 Emitting unit VEGAMIP T61
- 2 Receiving unit VEGAMIP R61 with control electronics
- 3 Housing lid
- 4 Housing with control electronics
- 5 Process fitting

Several antenna versions are available for different applications.

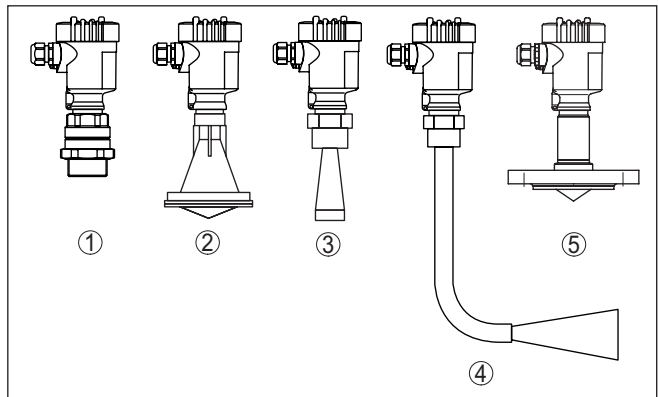

Fig. 2: Antenna versions

- 1 Threaded version, internal horn antenna with PTFE cover
- 2 Plastic encapsulated antenna with PP cover
- 3 Horn antenna (316L)
- 4 VEGAMIP 61 with angled antenna extension
- 5 Encapsulated horn antenna with PTFE cover

Functional principle	The emitting unit transmits a focused microwave signal via horn antenna to the receiving unit on the opposite side. If there is medium between emitting and receiving unit, the signal is damped. This change is detected by the built-in electronics module and converted into a switching command.
3.3 Packaging, transport and storage	
Packaging	Your instrument was protected by packaging during transport. Its capacity to handle normal loads during transport is assured by a test based on ISO 4180. The packaging consists of environment-friendly, recyclable cardboard. For special versions, PE foam or PE foil is also used. Dispose of the packaging material via specialised recycling companies.
Transport	Transport must be carried out in due consideration of the notes on the transport packaging. Nonobservance of these instructions can cause damage to the device.
Transport inspection	The delivery must be checked for completeness and possible transit damage immediately at receipt. Ascertained transit damage or concealed defects must be appropriately dealt with.
Storage	Up to the time of installation, the packages must be left closed and stored according to the orientation and storage markings on the outside. Unless otherwise indicated, the packages must be stored only under the following conditions: <ul style="list-style-type: none"> ● Not in the open ● Dry and dust free ● Not exposed to corrosive media ● Protected against solar radiation ● Avoiding mechanical shock and vibration
Storage and transport temperature	<ul style="list-style-type: none"> ● Storage and transport temperature see chapter " <i>Supplement - Technical data - Ambient conditions</i> " ● Relative moisture 20 ... 85 %
Lifting and carrying	With instrument weights of more than 18 kg (39.68 lbs) suitable and approved equipment must be used for lifting and carrying.
3.4 Accessories	
	The instructions for the listed accessories can be found in the download area on our homepage.
Protective cover	The protective cover protects the sensor housing against soiling and intense heat from solar radiation.
Flanges	Screwed flanges are available in different versions according to the following standards: DIN 2501, EN 1092-1, BS 10, ASME B 16.5, JIS B 2210-1984, GOST 12821-80.

Mounting adapter "Abrasion protection"

In case of extremely abrasive conditions you can cover the emitting and receiving units with a ceramic abrasion protection. This mounting adapter "Abrasion protection" is screwed onto the thread of VEGAMIP 61 like an adapter.

The mounting adapter "Abrasion protection" can only be used with the threaded version (internal horn antenna with PTFE cover)

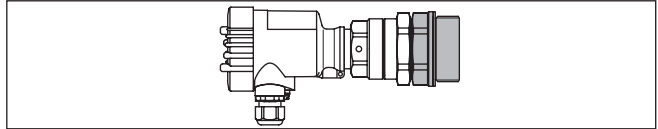

Fig. 3: VEGAMIP 61 with ceramic mounting adapter "Abrasion protection" -40 ... +80 °C (-40 ... +176 °C)

Mounting adapter "High temperature"

With high process temperatures exceeding 80 °C, you have to use a mounting adapter "High temperature" for the emitting and the receiving unit. The mounting adapter "High temperature" can only be used with the threaded version (internal horn antenna with PTFE cover).

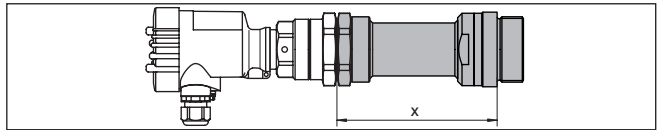

Fig. 4: VEGAMIP 61 with mounting adapter "High temperature" -40 ... +450 °C (-40 ... +842 °F)

x Length: Mounting adapter "High temperature"

Mounting adapter "High temperature with extension"

In case of high process temperatures of more than 80 °C you have to use a "high temperature" mounting adapter for the emitting and receiving unit. As an option, the "high temperature" mounting adapter can be also equipped with extension for front-flush mounting. Thus the instrument can also be mounted into long sockets where there is danger of buildup in the socket. The extension is available in five lengths: 40, 60, 80 100 and 150 mm (1.57, 2.36, 3.15, 3.94, 5.91 in).

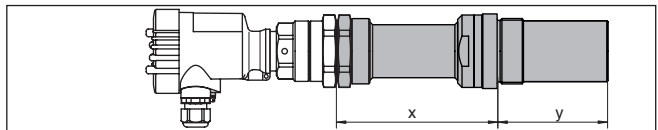

Fig. 5: VEGAMIP 61 with mounting adapter "High temperature with extension" -40 ... +450 °C (-40 ... +842 °F)

4 Mounting

4.1 General instructions

Screwing in

Devices with threaded fitting are screwed into the process fitting with a suitable wrench via the hexagon.

See chapter " *Dimensions*" for wrench size.



Warning:

The housing or the electrical connection may not be used for screwing in! Depending on the device version, tightening can cause damage, e. g. to the rotation mechanism of the housing.

Process conditions



Note:

For safety reasons, the instrument must only be operated within the permissible process conditions. You can find detailed information on the process conditions in chapter " *Technical data*" of the operating instructions or on the type label.

Hence make sure before mounting that all parts of the instrument exposed to the process are suitable for the existing process conditions.

These are mainly:

- Active measuring component
- Process fitting
- Process seal

Process conditions in particular are:

- Process pressure
- Process temperature
- Chemical properties of the medium
- Abrasion and mechanical influences

Protection against moisture

Protect your instrument against moisture ingress through the following measures:

- Use a suitable connection cable (see chapter " *Connecting to power supply*")
- Tighten the cable gland or plug connector
- Lead the connection cable downward in front of the cable entry or plug connector

This applies mainly to outdoor installations, in areas where high humidity is expected (e.g. through cleaning processes) and on cooled or heated vessels.



Note:

Make sure that during installation or maintenance no moisture or dirt can get inside the instrument.

To maintain the housing protection, make sure that the housing lid is closed during operation and locked, if necessary.

Cable glands

Metric threads

In the case of instrument housings with metric thread, the cable glands are screwed in at the factory. They are sealed with plastic plugs as transport protection.

You have to remove these plugs before electrical connection.

NPT thread

In the case of instrument housings with self-sealing NPT threads, it is not possible to have the cable entries screwed in at the factory. The free openings for the cable glands are therefore covered with red dust protection caps as transport protection. The dust protection caps do not provide sufficient protection against moisture.

Prior to setup you have to replace these protective caps with approved cable glands or close the openings with suitable blind plugs.

Switching point

4.2 Mounting instructions

If possible, install VEGAMIP 61 in a position where strong signal damping by the medium is expected.

Avoid mounting the instrument too close to the vessel wall. Reflections from the vessel wall or from vessel installation can influence the switching accuracy.

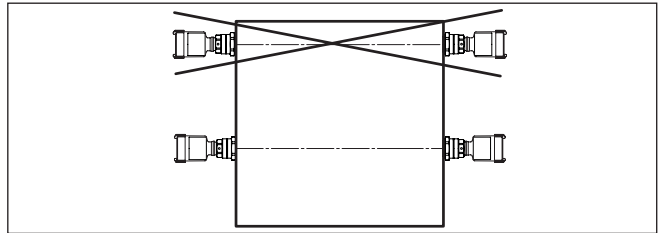

Fig. 6: Installation position (top view)

Medium thickness

The VEGAMIP 61 requires a minimum medium thickness to detect different products.

Dependent on the medium there will be a respective medium thickness.

The properties of the medium are also dependent on the granulation size, the bulk density and the moisture content.

Some exemplary reference values for the min. strength of the medium:

Medium type	Medium	Min. medium thickness
Plastic granules	PTFE, PS	> 1000 mm
	PP, PE, HDPE, POM	> 500 mm
	PA, PVC, PVDF	> 250 mm

Medium type	Medium	Min. medium thickness
Foodstuffs and wood	Flour	> 100 mm
	Cereals, corn, rice	> 100 mm
	Wood chips (dry)	> 500 mm
	Wood chips (moist)	> 100 mm
Mineral products, ore	Stones (e.g. limestone)	> 100 mm
	Cement, clinker	> 100 mm
	Glass (crushed)	> 100 mm
	Coal	> 50 mm
	Bauxite	> 100 mm
	Ore	> 100 mm

Inflowing medium

If VEGAMIP 61 is mounted in the filling stream, unwanted false measurement signals can be generated. For this reason, mount VEGAMIP 61 at a position in the vessel where no disturbances, e.g. from filling openings, agitators, etc., can occur.

Non-metallic vessels

Microwaves can penetrate non-conductive materials. Hence, it is possible to measure through the wall of non-conductive vessels.

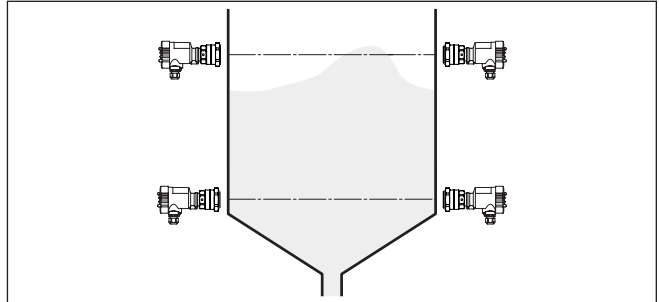

Fig. 7: Bulk solids vessel of plastic

Metal vessels

In metal vessels, you have to mount VEGAMIP 61 on flanges or threaded sockets. It is also possible to measure through a window. In general, all products such as glass, ceramic and plastic are suitable as window material.

Max. thickness of the window material:

Type of material	Window material	Max. thickness
Plastics	PTFE, PS	< 5000 mm
	PP, PE, HDPE, POM	< 1000 mm
	PA, PVC, PVDF	< 500 mm
	Rubber	< 50 mm

Type of material	Window material	Max. thickness
Glass or ceramic	Inspection glass	< 200 mm
	Aluminiumoxide ceramic Al_2O_3	< 200 mm
	Abrasion protection (ceramic)	< 100 mm
Isolating material	Mineral wool	< 1000 mm
	Ceramic fibre plates	< 1000 mm
	Fireclay bricks	< 500 mm

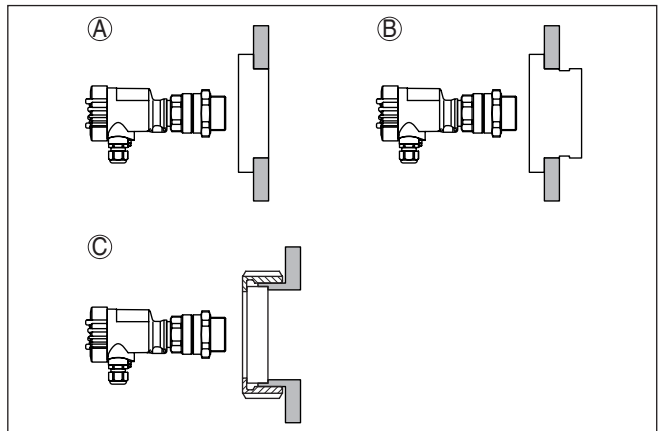

Fig. 8: Installation in front of a vessel window

- A Window of non-conductive material, for example, glass, plastic, etc.
- B Mounting with condensation on the inner wall of the vessel
- C Inspection glass fitting

Concrete vessel

In general, the same as for metal vessels applies to concrete vessels due to the steel braining.

Wood vessels

In general, the same as for metal vessels applies to wood vessels due to the liquid absorption of the wood.

Pipelines

VEGAMIP 61 can be used for detection of products in pipelines. In pipelines of non-metallic products such as plastic or glass, the measured product can be detected through the pipe wall.

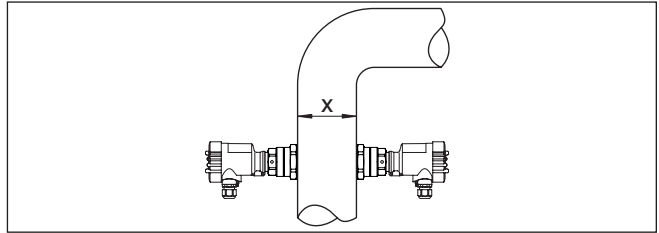

Fig. 9: Installation in pipelines

x Min. distance 100 mm (3.94 in)

Threaded version

Mount the threaded version of VEGAMIP 61 in the following way:

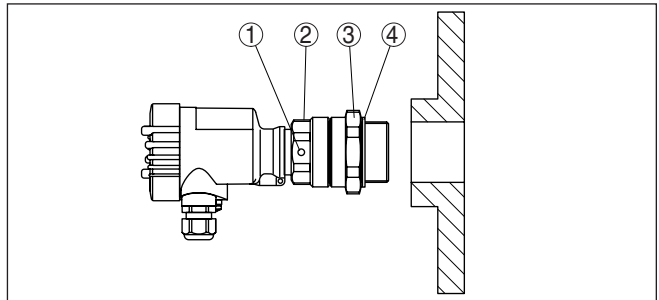

Fig. 10: VEGAMIP 61, threaded version G1½

- 1 Polarisation marking
- 2 Instrument hexagon
- 3 Counter nut
- 4 Process seal

1. Insert the supplied process seal (4) before screwing in the instrument
2. To screw VEGAMIP 61 in, use the instrument hexagon (2) below the housing.
Screw the instrument in and tighten it lightly with a flat spanner
3. Turn the sensor back (max. 180°) to reach the required orientation of the polarisation marking (1)
4. Hold the instrument in this position and tighten with the counter nut (3)



Caution:

The housing must not be used to screw the instrument in! Applying tightening force can damage internal parts of the housing.



Note:

In the case of VEGAMIP 61 with NPT thread, the instrument seals in the thread itself. Hence, no counter nut is necessary for these versions.

Buildup

Avoid long nozzles in which the medium can remain and if possible, mount VEGAMIP 61 front-flush. This applies mainly if buildup and dust are expected.

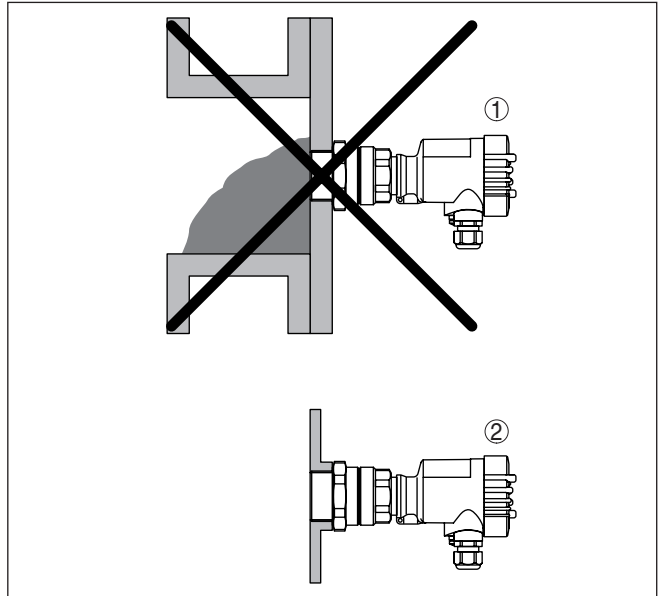

Fig. 11: Front flush mounting

- 1 Unfavourable mounting - bulk solid can settle in front of the sensor
- 2 Correct front-flush mounting

If a front-flush mounting is not possible, you can fill long nozzles with a plastic or ceramic cylinder to avoid buildup of bulk solids and dust deposits. Select the material according to the diameter of the nozzle and adapt the length as far as possible to the shape of the vessel wall. Secure the filling material against falling out or turning. If using a fixing screw is technically not possible, you can secure the material in the nozzle with an adhesive.

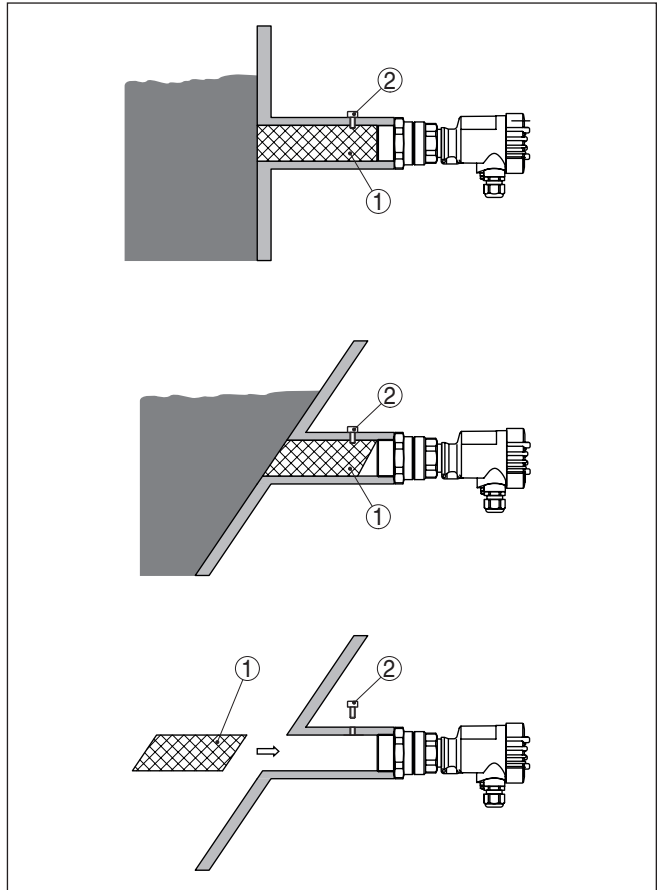

Fig. 12: Front flush mounting

- 1 Plastic or ceramic material
- 2 Fixing screw (if technically possible)

Abrasive medium

In very abrasive products, the VEGAMIP 61 should be installed with a mounting adapter "Abrasion protection".

This mounting adapter "Abrasion protection" is screwed onto the thread of VEGAMIP 61 like an adapter.

The mounting adapter "Abrasion protection" can only be used with the threaded version (internal horn antenna with PTFE cover)

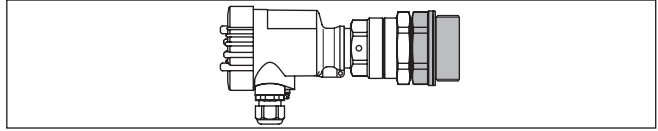

Fig. 13: VEGAMIP 61 with ceramic mounting adapter "Abrasion protection" -40 ... +80 °C (-40 ... +176 °C)

As an alternative you can install the VEGAMIP 61 in front of a suitable window. In such case, use a respectively resistant window material.

High process temperatures

With high process temperatures above 80 °C, you have to use a "high temperature" mounting adapter for the emitting and receiving unit.

It is mounted onto the thread of VEGAMIP 61.

The "high temperature" mounting adapter is available in two temperature stages.

- -40 ... +250 °C (-40 ... +482 °F), length x: 150 mm (5.9 in)
- -40 ... +450 °C (-40 ... +842 °F), length x: 300 mm (11.8 in)

The mounting adapter "High temperature" can only be used with the threaded version (internal horn antenna with PTFE cover)

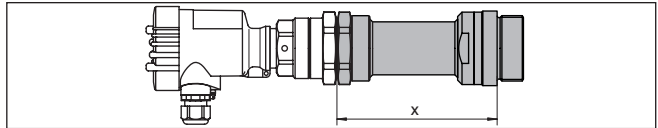

Fig. 14: VEGAMIP 61 with mounting adapter "High temperature" -40 ... +450 °C (-40 ... +842 °F)

x Length: Mounting adapter "High temperature"

As an option, the "high temperature" mounting adapter can be also equipped with an extension for front-flush mounting. Thus the instrument can also be mounted into long nozzles where there is danger of buildup in the nozzle. The extension is available in five lengths: 40, 60, 80, 100 and 150 mm (1.57, 2.36, 3.15, 3.94, 5.91 in).

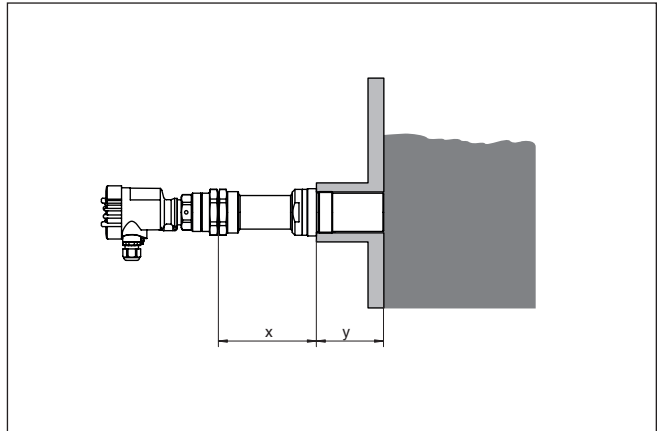

Fig. 15: Mounting adapter "High temperature with extension" $-40 \dots +450 \text{ }^{\circ}\text{C}$
 $(-40 \dots +842 \text{ }^{\circ}\text{F})$ for front-flush mounting

- x* Length: Mounting adapter "High temperature"
y Extension length 40, 60, 80, 100 or 150 mm (1.57, 2.36, 3.15, 3.94, 5.91 in)

Vibrations

In case of strong vessel vibrations, the VEGAMIP 61 should be mounted with anti vibration blocks or rubber buffers.

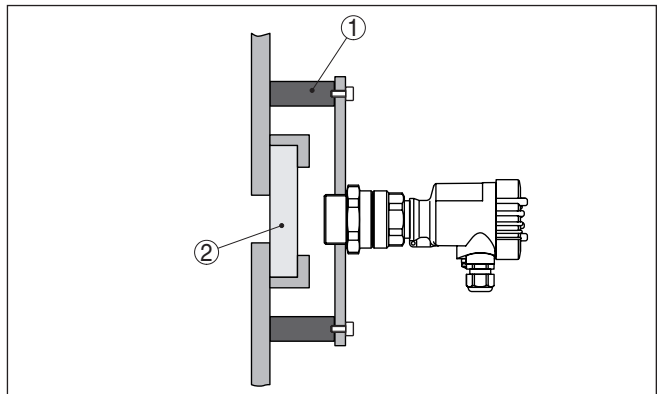

Fig. 16: Installation with vessel vibrations

- 1 Anti vibration blocks or rubber buffers
- 2 Window of non-conductive material, for example, glass, plastic, etc.

Orientation of the sensor Angle

To get an optimal switching signal, the two sensors must be aligned to each other. The accuracy must be in a range of $\pm 5^{\circ}$.

Axis offset

The axes of the two sensors can be offset up to $< 5\%$ of the sensor distance (d) from each other. Example: with a distance of 1000 mm

between them, the two sensors be offset from each other up to max. 50 mm.

General rule: the bigger the antenna and the better it focusses, the more precise the orientation has to be.

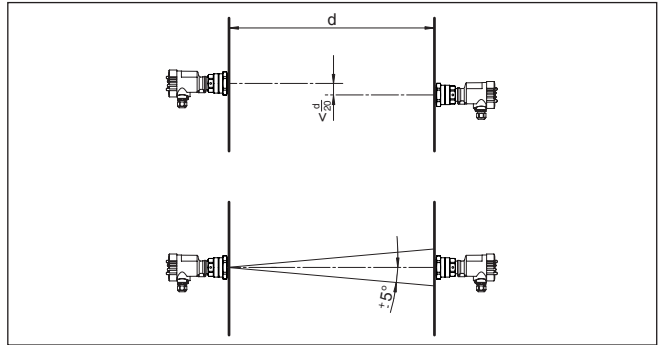

Fig. 17: Orientation of the sensors - Angle and axis offset

Polarisation direction

The emitting unit emits electromagnetic waves. The polarisation plane is the direction of the electrical wave component. Its position is marked on the instrument hexagon by polarisation markings.

For a reliable function, the emitting and receiving units must be installed in the same polarisation direction.

If multiple instrument pairs are installed in one vessel, the instrument pairs can be coded, so to speak, by mounting them in different polarisation positions so that they do not influence one another.

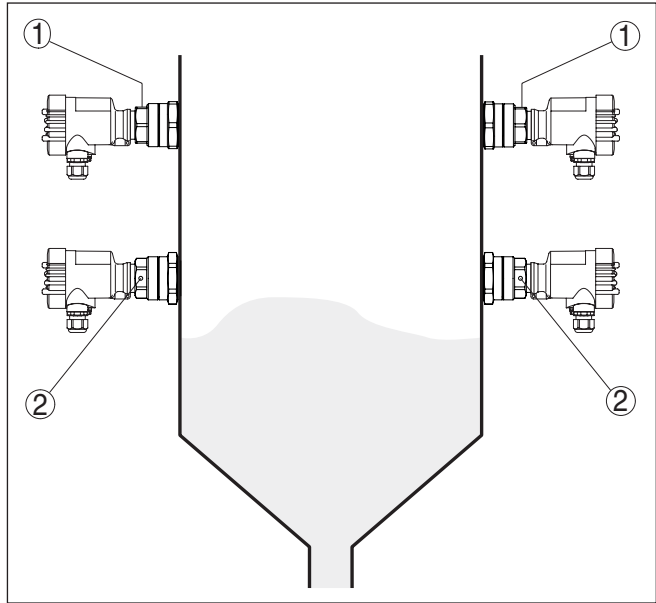

Fig. 18: Orientation according to the polarisation direction

- 1 Polarisation marking on top
- 2 Polarisation marking on the side

Special mounting options In tight mounting spaces or spaces subject to high temperatures, the signal of VEGAMIP 61 can be guided via a deflector. You can use a metal plate for this or an angled antenna extension. This deflector can be positioned on the emitting unit side or on the receiving unit side. In products with low dielectric value, we recommend using an instrument version with antenna extension because it focusses the signal optimally and has no signal loss. On instrument versions with detachable horn antenna, the antenna extension can be retrofitted. To minimize false echoes, take note of the polarisation plane. Keep the position of the polarisation marking with respect to the antenna extension in mind. Mount the antenna extension according to the following illustration.

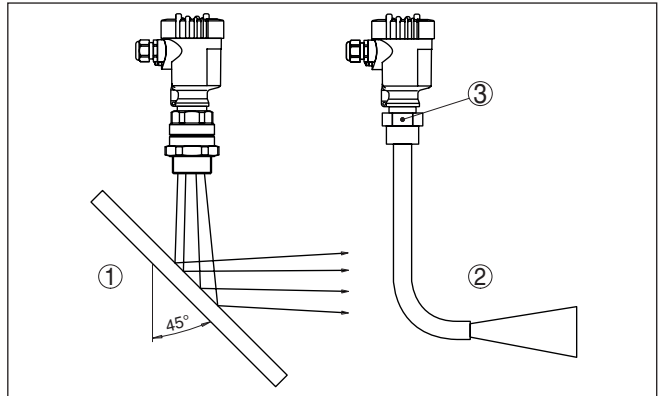

Fig. 19: Possibilities for signal deflection

- 1 Metal plate for deflection of the microwave signal
- 2 Bent antenna extension
- 3 Polarisation marking

5 Connecting to power supply

5.1 Preparing the connection

Safety instructions

Always keep in mind the following safety instructions:

- Carry out electrical connection by trained, qualified personnel authorised by the plant operator
- If overvoltage surges are expected, overvoltage arresters should be installed



Warning:

Only connect or disconnect in de-energized state.

Voltage supply

Connect the operating voltage according to the following diagrams. Take note of the general installation regulations. As a rule, connect VEGAMIP 61 to vessel ground (PA), or in case of plastic vessels, to the next ground potential. On the side of the instrument housing there is a ground terminal between the cable entries. This connection serves to drain off electrostatic charges. In Ex applications, the installation regulations for hazardous areas must be given priority.

The data for power supply are specified in chapter " *Technical data*".

Connection cable

The instrument is connected with standard two-wire cable without shielding. If electromagnetic interference is expected which is above the test values of EN 61326 for industrial areas, shielded cable should be used.

Make sure that the cable used has the required temperature resistance and fire safety for max. occurring ambient temperature

Use cable with round cross section for instruments with housing and cable gland. To ensure the seal effect of the cable gland (IP protection rating), find out which cable outer diameter the cable gland is suitable for.

Use a cable gland fitting the cable diameter.

Cover all housing openings conforming to standard according to EN 60079-1.

Cable glands

Metric threads:

In the case of instrument housings with metric thread, the cable glands are screwed in at the factory. They are sealed with plastic plugs as transport protection.



Note:

You have to remove these plugs before electrical connection.

NPT thread:

In the case of instrument housings with self-sealing NPT threads, it is not possible to have the cable entries screwed in at the factory. The free openings for the cable glands are therefore covered with red dust protection caps as transport protection.



Note:

Prior to setup you have to replace these protective caps with approved cable glands or close the openings with suitable blind plugs.

On plastic housings, the NPT cable gland or the Conduit steel tube must be screwed into the threaded insert without grease.

Max. torque for all housings, see chapter " *Technical data*".

5.2 Connection procedure

Connection technology

The voltage supply and signal output are connected via the spring-loaded terminals in the housing.

Connection procedure

Proceed as follows:

1. Unscrew the housing lid
2. Loosen compression nut of the cable gland and remove blind plug
3. Remove approx. 10 cm (4 in) of the cable mantle, strip approx. 1 cm (0.4 in) of insulation from the ends of the individual wires
4. Insert the cable into the sensor through the cable entry



Fig. 20: Connection steps 4 and 5

5. Insert the wire ends into the terminals according to the wiring plan



Information:

Solid cores as well as flexible cores with wire end sleeves are inserted directly into the terminal openings. In case of flexible cores without end sleeves, press the terminal from above with a small flat head screwdriver, the terminal opening is then free. When the flat head screwdriver is released, the terminal closes again.

6. Check the hold of the wires in the terminals by lightly pulling on them
7. Connect the shielding to the internal ground terminal, connect the external ground terminal to potential equalisation
8. Tighten the compression nut of the cable entry gland. The seal ring must completely encircle the cable
9. Screw the housing lid back on

The electrical connection is finished.



Information:

The terminal block is pluggable and can be removed from the electronics. To do this, lift the terminal block with a small screwdriver

and pull it out. When reinserting the terminal block, you should hear it snap in.

5.3 Wiring plan, single chamber housing

Wiring plan

We recommend connecting VEGAMIP 61 in such a way that the switching circuit is open when there is a level signal, line break or failure (safe state).

The terminals 1 and 5 as well as 2 and 8 are internally connected. Hence PNP or NPN action can be selected through the electrical connection.

Connection - PNP action

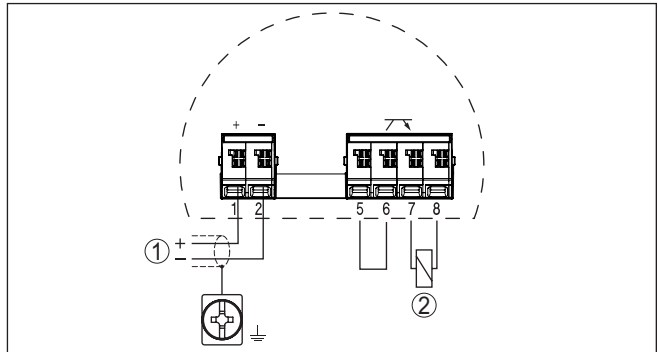

Fig. 21: Wiring plan receiving unit - VEGAMIP 61 (receiver) - PNP action

- 1 Voltage supply
- 2 Load

Connection - NPN action

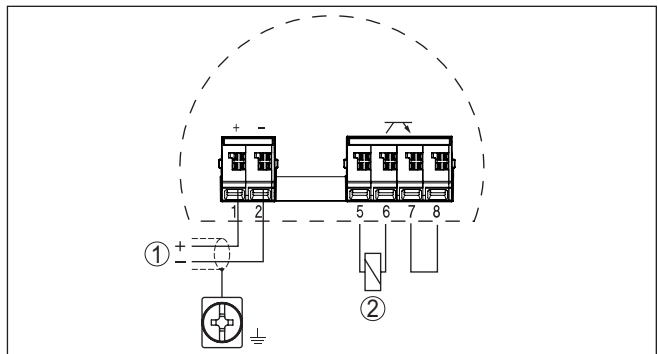

Fig. 22: Wiring plan receiving unit - VEGAMIP 61 (receiver) - NPN action

- 1 Voltage supply
- 2 Load

Connection - floating

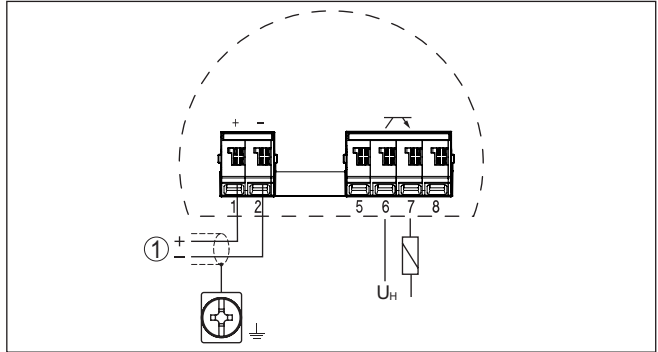

Fig. 23: Wiring plan receiving unit - VEGAMIP 61 (receiver) - floating

- 1 Voltage supply
- U_H Auxiliary voltage

6 Setup

6.1 Adjustment system

Display and adjustment elements

On the electronics module you will find the following display and adjustment elements:

The figures in brackets refer to the following illustration.

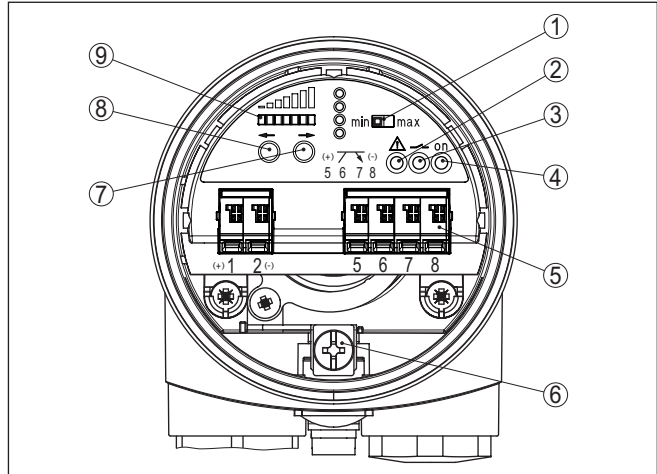

Fig. 24: Electronics module MP6X S receiver unit - Transistor output

- 1 Mode switch for selecting the switching behaviour (min./max.)
- 2 Control lamp (LED) for indication of a fault (red)
- 3 Signal lamp (LED) for indication of the switching status (yellow)
- 4 Control lamp (LED) for indication of the instrument function (green)
- 5 Connection terminals
- 6 Ground terminal
- 7 Key for setting the sensitivity and the switching delay (-->)
- 8 Key for setting the sensitivity and the switching delay (<--)
- 9 LED indicating board for indication of reception strength (yellow)

Signal lamps (2, 3, 4)

There are three control lamps (LED) on the electronics module

Control lamp (red) for indication of a fault (2)

This signal lamp shows the fault status of the instrument.

Control lamp (yellow) for indication of the switching condition (3)

The signal lamp signals the switching condition of the switching output.

Control lamp (green) for indication of the instrument function (4)

The green signal lamp (on) shows the operating state of the instrument as soon as voltage supply is connected correctly.

Mode switch (1)

With the mode switch (min./max.) you can change the switching status of the transistor output. You can set the required mode according to the " *Function table*" (max. - max. detection or overflow protection, min. - min. detection or dry run protection).

Sensitivity adjustment (7, 8)

With these keys (7 and 8) you can adjust the switching point to the medium.

Depending on the process, the sensitivity of VEGAMIP 61 must be set higher or lower.

Pressing the "<--" key makes the sensor more sensitive. Pressing the "-->" key makes the sensor less sensitive.

You can also adjust the switching delay with the two keys.

LED indication strip - receive level (9)

By means of the LED indicating strip, you can see the actual receive level during adjustment.

When the indication moves to the right, the instrument is less sensitive, to the left more sensitive.

6.2 Adjustment







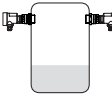

Prerequisites

The microwave barrier can only be adjusted when it is uncovered. Make sure that no measured medium or vessel installations are between the emitting and receiving unit.

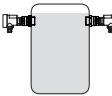
Mode

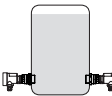
Select the requested mode (min./max.) according to the function table.

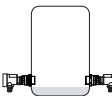
The following function table provides an overview of the switching statuses depending on the set mode and level.

	Level	Switching status	Signal lamp - Switching output (yellow)
Max. mode of operation Overflow protection		closed	
Max. mode of operation Overflow protection		open	
Min. mode of operation Dry run protection		closed	
Min. mode of operation Dry run protection		open	

	Level	Switching status	Signal lamp - Switching output (yellow)
Failure of the supply voltage (max./min. mode of operation)	any	open	○
Fault	any	open	○ Red fault LED lights up

Depending on the switching function your output should carry out, you can determine the switching direction by means of the slide switch.

- For maximum indication or overflow protection set the slide switch to position max.
- For minimum indication or dry run protection, set the slide switch to position min.

The transistor output is closed when the yellow signal lamp lights.

Sensitivity adjustment

With the two keys you can change the LED indication strip and adjust the switching point to the medium.

The keys are recessed to avoid unintentional changes of the settings. To make an adjustment, use eg a small screwdriver.

If you press one of the keys for more than two seconds, the adjustment range shifts automatically in the respective direction. The greater the distance between emitting and receiving unit, the greater the adjustment range of the indication. The LED indication strip always shows a small section of the actual measuring range.

Pressing the "<--" key makes the sensor more sensitive. Pressing the "-->" key makes the sensor less sensitive.

Press the respective key until the indication is within the LED indication strip. This means one or two LEDs on the LED indication strip will light up.

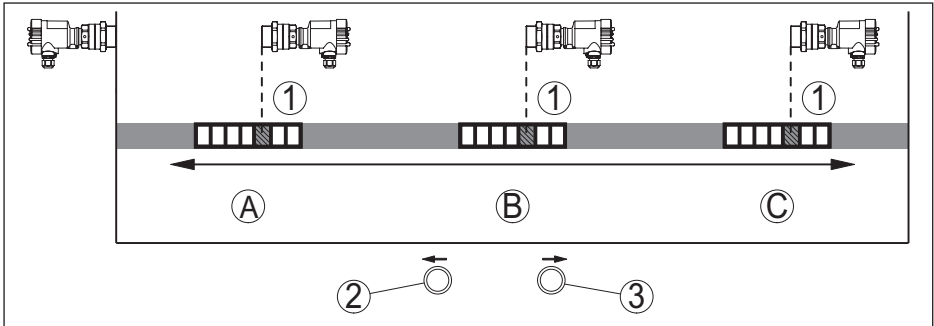

Fig. 25: Indication strip

- 1 Indication (LED indication strip)
- 2 More sensitive - Key to the left
- 3 Less sensitive - Key to the right
- A Medium: Plastics (PP, PVC ...), solvents
- B Medium: Building materials (sand, stones ...)
- C Medium: Conductive substances (coal, ore, salt ...)

Set the indication approximately to the middle of the LED indicating board until the yellow status indication changes condition.

Depending on the vessel size, process and/or medium, you have to adjust the sensitivity of VEGAMIP 61 to more or less sensitive. In products with weak signal damping, in small vessels or pipelines or with buildup, it might be necessary to test the switching function.

Receive level

By means of the LED indicating strip, you can see the actual receive level during adjustment.

When the indication moves to the right, the instrument is less sensitive, to the left more sensitive.

Medium provides good signal damping

In applications with products providing good signal damping (for example rocks, ore, sand, cement) and where buildup and contamination is expected, you should adjust the instrument to more insensitive. In this case, the VEGAMIP 61 switches only when there is a relatively strong signal damping by the medium. Buildup does not influence the measurement.

In case of buildup, press the key (to the right) until the flashing LEDs are at the right edge of the LED indicating strip. For strong buildup, you can press the key several times to make the instrument less sensitive. The indication of the LED indicating strip does not change, but the instrument will become a little less sensitive with each pressing of the key.

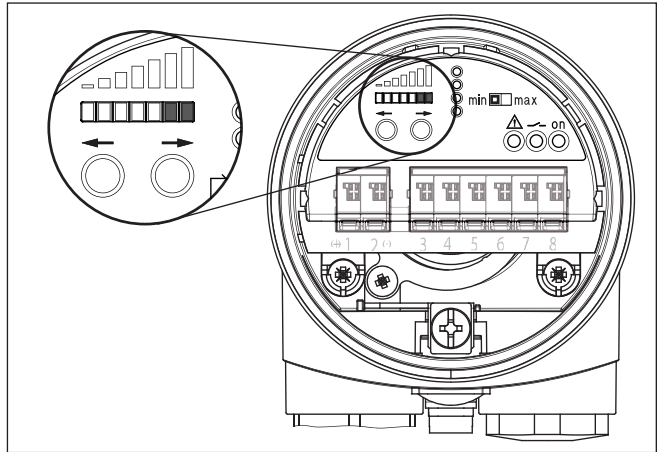

Fig. 26: LED indication strip - Setting for products with strong signal damping

If there is strong buildup during operation, adjustment with buildup is recommended. A short period of operation is probably sufficient to create buildup, or buildup can be created artificially or imitated.

Medium provides low signal damping

In applications with products providing only weak signal damping (eg plastic granules, cereals), you should adjust the instrument to more sensitive. This way, the VEGAMIP 61 switches very sensitively, even with a relatively low coverage by the product.

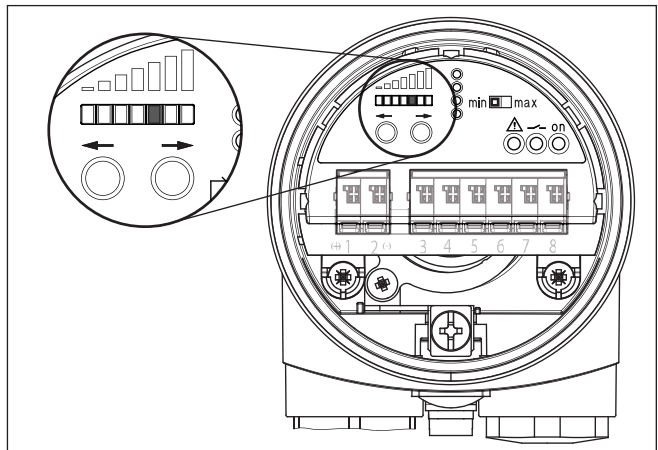

Fig. 27: LED indicating strip - Setting for products with weak signal damping

Switching delay

You can adjust the switching delay with the help of the LED indicating strip.

Push the two keys (7) and (8) simultaneously for approximately 2 s until the LED indication flashes.

With the two keys you can select the requested switching delay according to the following illustration.

The switching delay can be adjusted in seven steps between 100 ms and 20 s.

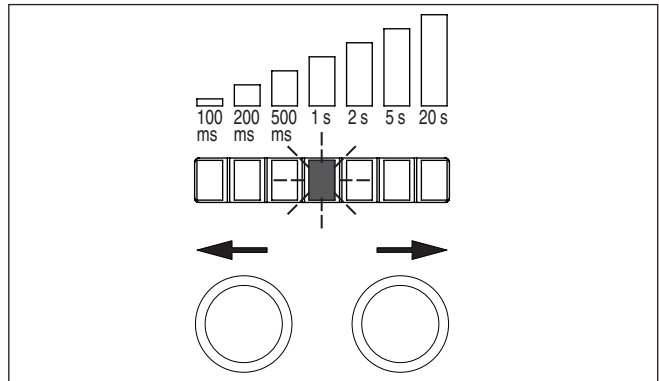

Fig. 28: Adjust switching delay - LED indication flashes

If the indication moves to the right, the switching delay will be longer, to the left shorter.

The indication returns automatically to the indication of the actual receive level after approximately 10 s.

Simulation

If possible, simulate a filling between emitting and receiving unit with your hand or a metal sheet and check if the switching point is adjusted correctly. If the control lamp changes its switching status, the switching function is correct

7 Maintenance and fault rectification

7.1 Maintenance

Maintenance

If the device is used properly, no special maintenance is required in normal operation.

Cleaning

The cleaning helps that the type label and markings on the instrument are visible.

Take note of the following:

- Use only cleaning agents which do not corrode the housings, type label and seals
- Use only cleaning methods corresponding to the housing protection rating

7.2 Rectify faults

Reaction when malfunction occurs

The operator of the system is responsible for taking suitable measures to rectify faults.

Fault rectification

The first measure to take is to check the output signal. In many cases, the causes can be determined this way and the faults quickly rectified.

Checking the switching signal

Error	Cause	Rectification
VEGAMIP 61 signals "covered" without being submerged (overflow protection) or VEGAMIP 61 signals "uncovered" when being submerged (dry run protection)	Operating voltage too low	Check operating voltage
	Buildup on the sensor	Check if there is buildup on the two sensors, and if so, remove it. Note the instructions in chapter "Mounting" if there is buildup in the nozzle.
	Wrong mode selected	Set the correct mode on the mode switch (max.: overflow protection, min.: dry run protection). Wiring should be carried out according to the idle current principle.
	Unfavourable installation location	Mount the sensor (emitter/receiver) at a location where there is a large quantity of measured product between the emitting and receiving units.
		Mount the sensor (emitter/receiver) at a location where there are no interfering installations or moving parts.
	Electronics defective	Press the mode switch. If the instrument then does not change the mode, the electronics module may be defective. Exchange the electronics module.
Sensor defective	Operate the mode switch (min./max.). If the instrument then switches mode, the sensor may be covered with buildup or mechanically damaged. If the switching function in the correct mode is faulty, return the instrument for repair.	

Error	Cause	Rectification
Signal lamp lights red	Operating voltage too low	Check operating voltage
	Electronics module has detected an internal malfunction	Exchange the instrument or send it in for repair
Instrument switches delayed	Check switching delay	Adjust switching delay correctly
Instrument switches frequently with certain levels	Wave movements in the vessel	Adjust or increase switching delay
	Effects through interfering reflections	Adjust the instrument to less sensitive

Reaction after fault rectification

Depending on the reason for the fault and the measures taken, the steps described in chapter " *Setup*" must be carried out again or must be checked for plausibility and completeness.

24 hour service hotline

Should these measures not be successful, please call in urgent cases the VEGA service hotline under the phone no. **+49 1805 858550**.

The hotline is also available outside normal working hours, seven days a week around the clock.

Since we offer this service worldwide, the support is provided in English. The service itself is free of charge, the only costs involved are the normal call charges.

7.3 Exchanging the electronics

If the electronics module is defective, it can be replaced by the user.



In Ex applications only an electronics module with respective Ex approval may be used.

You can find all the information you need to carry out an electronics exchange in the handbook of the new electronics module.

7.4 How to proceed if a repair is necessary

You can find an instrument return form as well as detailed information about the procedure in the download area of our homepage. By doing this you help us carry out the repair quickly and without having to call back for needed information.

Proceed as follows in case of repair:

- Print and fill out one form per instrument
- Clean the instrument and pack it damage-proof
- Attach the completed form and, if need be, also a safety data sheet outside on the packaging
- Ask the agency serving you to get the address for the return shipment. You can find the agency on our homepage.

8 Dismount

8.1 Dismounting steps

To remove the device, carry out the steps in chapters " *Mounting*" and " *Connecting to power supply*" in reverse.



Warning:

When dismantling, pay attention to the process conditions in vessels or pipelines. There is a risk of injury, e.g. due to high pressures or temperatures as well as aggressive or toxic media. Avoid this by taking appropriate protective measures.

8.2 Disposal



Pass the instrument on to a specialised recycling company and do not use the municipal collecting points.

Remove any batteries in advance, if they can be removed from the device, and dispose of them separately.

If personal data is stored on the old device to be disposed of, delete it before disposal.

If you have no way to dispose of the old instrument properly, please contact us concerning return and disposal.

9 Supplement

9.1 Technical data

General data

Material 316L corresponds to 1.4404 or 1.4435

Materials, wetted parts

- Process fitting - thread 316L
- Process fitting - flange 316L

Antenna	Instrument seal	Cover or wetted materials
Threaded version, internal horn antenna with PTFE cover	FKM (A+P 70.16.-06) Process seal: Klingersil C-4400	PTFE 316L
Plastic encapsulated antenna with PP cover	-	PP
Horn antenna (316L)	FKM (SHS FDM 70C3 GLT) FFKM (Kalrez 6375) Process seal: Klingersil C-4400	PTFE 316L
Encapsulated horn antenna with PTFE cover	-	PTFE
Mounting adapter "Abrasion protection" (optional) -1 ... +20 bar (-14,5 ... 290 psig) +80 °C (+176 °F)	FKM (A+P FPM 70.16-06) Process seal: Klingersil C-4400	Al ₂ O ₃ ceramic 316L
Mounting adapter "High temperature" (option) Unpressurized +250 °C (+482 °F)	Graphite Process seal: Klingersil C-4400	Al ₂ O ₃ ceramic 316L
Mounting adapter "High temperature" (option) Unpressurized +450 °C (+842 °F)	Graphite Process seal, provided by customer	Al ₂ O ₃ ceramic 316L

Materials, non-wetted parts

- Plastic housing Plastic PBT (Polyester)
- Aluminium die-cast housing Aluminium die-casting AlSi10Mg, powder-coated (Basis: Polyester)
- Stainless steel housing (precision casting) 316L
- Stainless steel housing (electropolished) 316L
- Seal between housing and housing lid Silicone
- Inspection window in housing cover Plastic housing: Polycarbonate (UL746-C listed)
Metal housing: Glass ¹⁾
- Ground terminal 316L

1) Aluminium, stainless steel precision casting and Ex d housing

- Cable gland	PA, stainless steel, brass
- Sealing, cable gland	NBR
- Blind plug, cable gland	PA
- Mounting adapter (option)	316L
Sensor length	See chapter "Dimensions"
Instrument weight (depending on process fitting)	0.8 ... 4 kg (0.18 ... 8.82 lbs)
Process fittings	
- Pipe thread, cylindrical (ISO 228 T1)	G1½ according to DIN 3852-A
- Pipe thread, conical (ASME B1.20.1)	1½ NPT
- Flanges	DIN from DN 50, ASME from 2"
- Mounting adapter	G2 or 2 NPT
Frequency range	K band, 24.085 GHz (ISM band)
Measuring range	0.1 ... 100 m (0.33 ... 328 ft)
Beam angle ²⁾	
- Threaded version, internal horn antenna with PTFE cover	20°
- Plastic encapsulated antenna with PP cover	10°
- Horn antenna (316L), ø 40 mm (1.575 in)	22°
- Horn antenna (316L), ø 48 mm (1.89 in)	18°
- Encapsulated antenna with PTFE cover, Flange DN 50, ASME 2"	18°
- Encapsulated antenna with PTFE cover, Flange DN 80 ... DN 150, ASME 3" ... 6"	10°
Torque for NPT cable glands and Conduit tubes	
- Plastic housing	max. 10 Nm (7.376 lbf ft)
- Aluminium/Stainless steel housing	max. 50 Nm (36.88 lbf ft)

Output variable

Output	Floating transistor output ³⁾
Load current	< 400 mA
Voltage loss	< 0.5 V
Switching voltage	< 55 V DC
Blocking current	< 10 µA
Modes (switchable)	min./max.

2) Outside the specified beam angle, the energy of the radar signal has a level of -3 dB (50 %).

3) Not overload resistant and not short-circuit proof

Measurement accuracy

Hysteresis	approximately 1 dB
Switching delay	adjustable from 0.1 ... 20 s (on/off)
Min. distance	100 mm (3.94 in)

Ambient conditions

Ambient, storage and transport temperature	-40 ... +80 °C (-40 ... +176 °F)
--	----------------------------------

Process conditions

Measured variable	Limit level of bulk solids and liquids
Process pressure ⁴⁾	
- VEGAMIP 61, threaded version, internal horn antenna with PTFE cover	-1 ... 4 bar/-100 ... 400 kPa (-14.5 ... 58 psig)
- VEGAMIP 61, plastic encapsulated antenna with PP cover	-1 ... 2 bar/-100 ... 200 kPa (-14.5 ... 29 psig)
- VEGAMIP 61, horn antenna (316L)	-1 ... 40 bar/-100 ... 4000 kPa (-14.5 ... 580 psig)
- VEGAMIP 61, encapsulated horn antenna with PTFE cover	-1 ... 16 bar/-100 ... 1600 kPa (-14.5 ... 232 psig)
- VEGAMIP 61 with mounting adapter "Abrasion protection"	-1 ... 20 bar/-100 ... 2000 kPa (-14.5 ... 290 psig)
- VEGAMIP 61 with mounting adapter "High temperature" 150 mm	unpressurized (IP67)
- VEGAMIP 61 with mounting adapter "High temperature" 300 mm	unpressurized (IP67)
Process temperature (thread or flange temperature)	
- VEGAMIP 61, threaded version, internal horn antenna with PTFE cover	-40 ... +80 °C (-40 ... +176 °F)
- VEGAMIP 61, plastic encapsulated antenna with PP cover	-40 ... +80 °C (-40 ... +176 °F)
- VEGAMIP 61, horn antenna (316L) - seal: FKM (SHS FDM 70C3 GLT)	-40 ... +130 °C (-40 ... +266 °F)
- VEGAMIP 61, horn antenna (316L) - seal: FFKM (Kalrez 6375)	-20 ... +130 °C (-4 ... +266 °F)
- VEGAMIP 61, encapsulated horn antenna with PTFE cover	-40 ... +200 °C (-40 ... +392 °F)
- VEGAMIP 61 with mounting adapter "Abrasion protection" (optional)	-40 ... +80 °C (-40 ... +176 °F)
- VEGAMIP 61 with mounting adapter "High temperature" 150 mm (optional)	-40 ... +250 °C (-40 ... +482 °F)
- VEGAMIP 61 with mounting adapter "High temperature" 300 mm (optional)	-40 ... +450 °C (-40 ... +842 °F)

4) Note max. pressure of the process fitting.

Electromechanical data

Options of the cable entry

- Cable entry M20 x 1.5; ½ NPT
- Cable gland M20 x 1.5; ½ NPT (cable diameter see below table)
- Blind plug M20 x 1.5; ½ NPT
- Closing cap ½ NPT

Material cable gland	Material seal insert	Cable diameter				
		4.5 ... 8.5 mm	5 ... 9 mm	6 ... 12 mm	7 ... 12 mm	10 ... 14 mm
PA	NBR	-	●	●	-	●
Brass, nickel-plated	NBR	●	●	●	-	-
Stainless steel	NBR	-	●	●	-	●

Wire cross-section (spring-loaded terminals)

- Massive wire, stranded wire 0.2 ... 2.5 mm² (AWG 24 ... 14)
- Stranded wire with end sleeve 0.2 ... 1.5 mm² (AWG 24 ... 16)

Voltage supply

- Operating voltage 20 ... 55 V DC
- Power consumption max. 0.8 W

Electrical protective measures

- Protection rating IP66/IP67 (NEMA Type 4X)
- Overvoltage category (IEC 61010-1) The feeding power supply unit can be connected to networks of overvoltage category III.
- Protection class II

9.2 Dimensions

VEGAMIP 61, housing versions

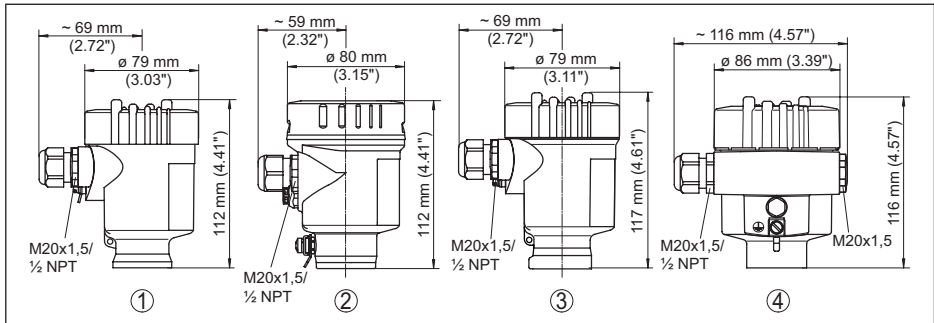

Fig. 29: Housing versions

- 1 Plastic single chamber
- 2 Stainless steel single chamber (electropolished)
- 3 Stainless steel single chamber (precision casting)
- 4 Aluminium - single chamber

VEGAMIP 61, threaded version

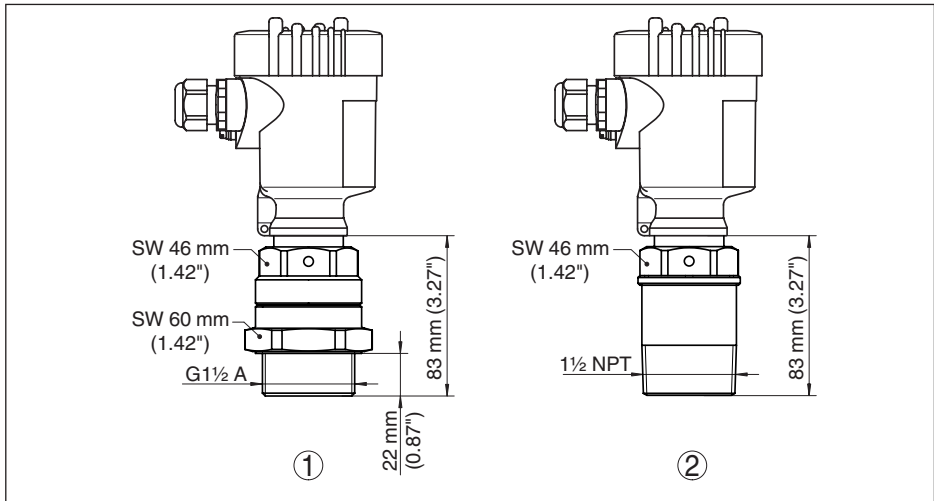

Fig. 30: VEGAMIP 61, internal horn antenna (threaded version)

- 1 Internal horn antenna with PTFE cover, threaded version G1 1/2
- 2 Internal horn antenna with PTFE cover, threaded version 1 1/2 NPT

VEGAMIP 61, encapsulated antennas

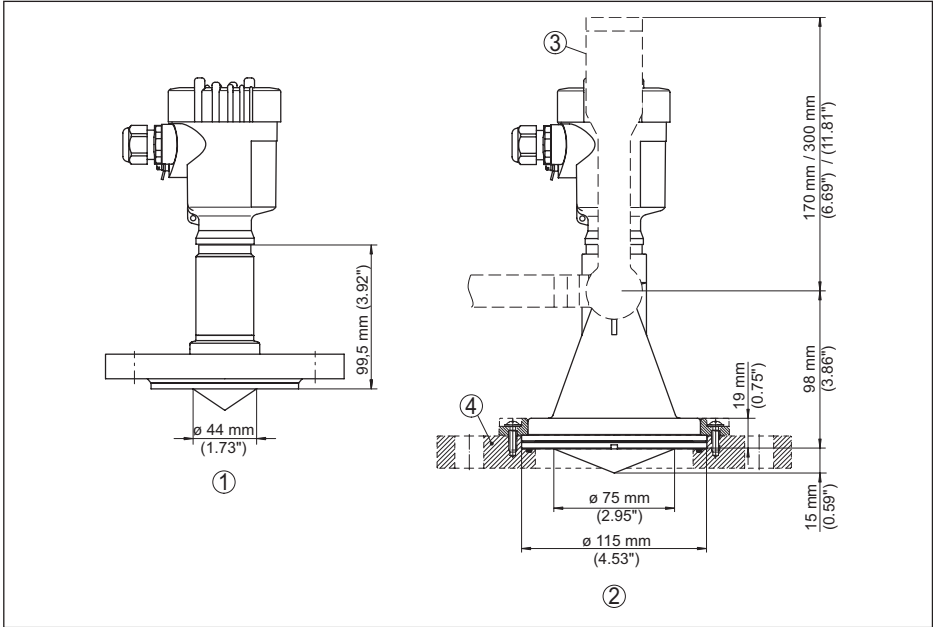

Fig. 31: VEGAMIP 61, encapsulated antennas

- 1 Encapsulated horn antenna with PTFE cover, flange version
- 2 Plastic encapsulated antenna with PP cover
- 3 Mounting strap
- 4 Adapter flange

VEGAMIP 61, horn antenna

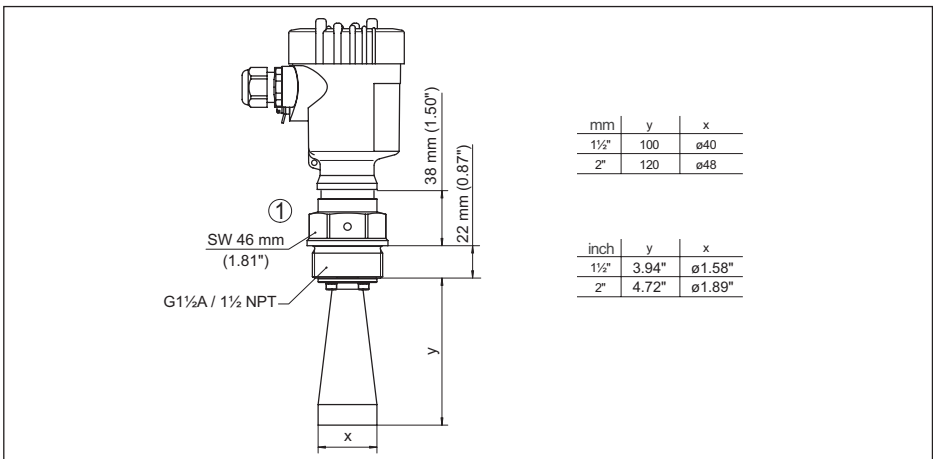

Fig. 32: VEGAMIP 61, horn antenna (316L)

VEGAMIP 61, mounting adapter "Abrasion protection" -40 ... +80 °C (-40 ... +176 °F)

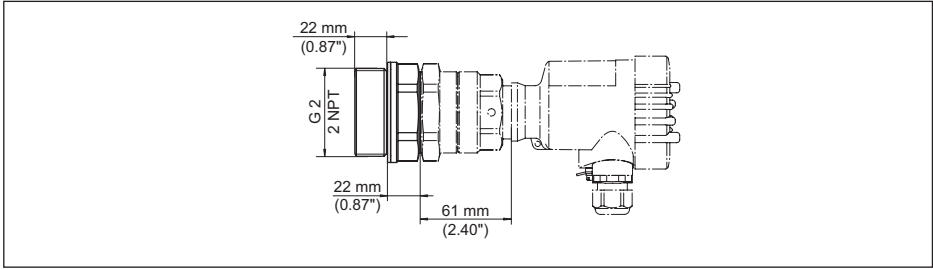

Fig. 33: Mounting adapter with ceramic cover (optional) for VEGAMIP 61 with internal horn antenna, threaded version G1½ with PTFE cover (also with 1½ NPT thread)

VEGAMIP 61, mounting adapter "High temperature" -40 ... +450 °C (-40 ... +842 °F)

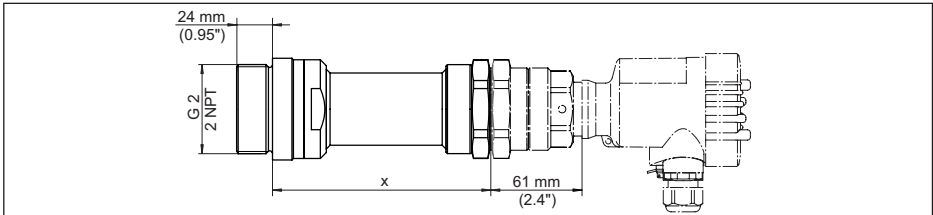

Fig. 34: Mounting adapter with ceramic cover (optional) for VEGAMIP 61 with internal horn antenna, threaded version G1½ with PTFE cover (also with 1½ NPT thread)

- x 150 mm (5.9 in), -40 ... +250 °C (-40 ... +482 °F)
- x 300 mm (11.8 in), -40 ... +450 °C (-40 ... +842 °F)

VEGAMIP 61, mounting adapter "High temperature with extension" -40 ... +450 °C (-40 ... +842 °F)

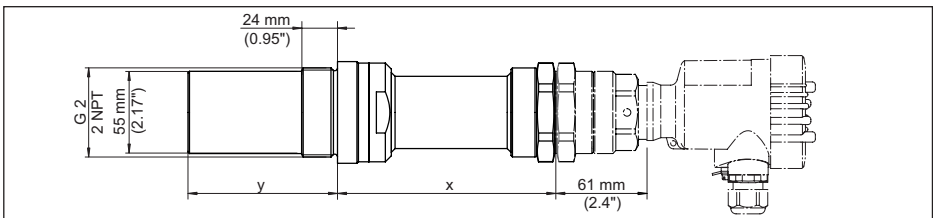

Fig. 35: Mounting adapter with extension for front-flush mounting, for VEGAMIP 61 with internal horn antenna, threaded version G1½ with PTFE cover (also with 1½ NPT thread)

- x 150 mm (5.9 in), -40 ... +250 °C (-40 ... +482 °F)
- x 300 mm (11.8 in), -40 ... +450 °C (-40 ... +842 °F)
- y Extension length 40, 60, 80, 100 or 150 mm (1.57, 2.36, 3.15, 3.94, 5.91 in)

9.3 Industrial property rights

VEGA product lines are global protected by industrial property rights. Further information see www.vega.com.

VEGA Produktfamilien sind weltweit geschützt durch gewerbliche Schutzrechte.

Nähere Informationen unter www.vega.com.

Les lignes de produits VEGA sont globalement protégées par des droits de propriété intellectuelle. Pour plus d'informations, on pourra se référer au site www.vega.com.

VEGA líneas de productos están protegidas por los derechos en el campo de la propiedad industrial. Para mayor información revise la pagina web www.vega.com.

Линии продукции фирмы ВЕГА защищаются по всему миру правами на интеллектуальную собственность. Дальнейшую информацию смотрите на сайте www.vega.com.

VEGA系列产品在全球享有知识产权保护。

进一步信息请参见网站 < www.vega.com。

9.4 Trademark

All the brands as well as trade and company names used are property of their lawful proprietor/originator.

INDEX**A**

Abrasion 18
Abrasion protection 11
Adjustment 28, 29
Application area 8

B

Bending 22
Buildup 17

C

Cable 24
Cable screening 24

E

Electronics module 35
Emitting unit 9

F

Fault rectification 34
Filling opening 14
Functional principle 10

M

Medium 13
Mode 29
Mounting adapter 11, 19

O

Orientation of the sensor 20

P

Pipelines 15
Polarisation direction 20
Potential equalisation 24

R

Receiving unit 9, 26, 28
Repair 35

S

Sensitivity adjustment 30
Service hotline 35
Shielding 24
Simulation 33
Switching delay 32
Switching point 13

T

Threaded version 16

Type label 8

Type of vessel

- Concrete vessel 15
- Metal vessels 14
- Non-metallic vessels 14
- Wood vessels 15

V

Vibrations 20

W

Wiring plan 26

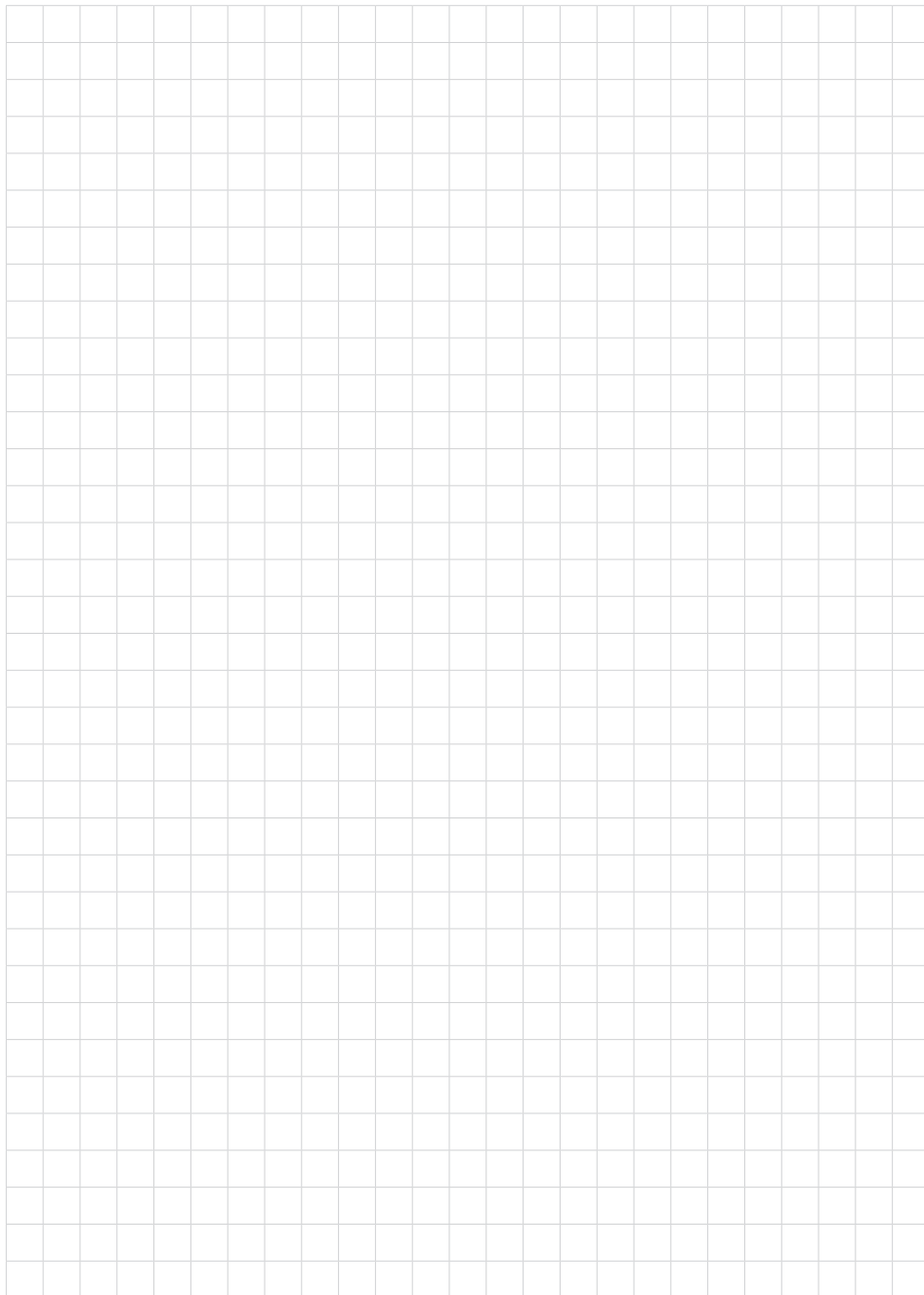

A large grid of graph paper for taking notes, consisting of 20 columns and 30 rows of small squares.

40694-EN-221012

Printing date:

VEGA

All statements concerning scope of delivery, application, practical use and operating conditions of the sensors and processing systems correspond to the information available at the time of printing.

Subject to change without prior notice

© VEGA Grieshaber KG, Schiltach/Germany 2022



40694-EN-221012

VEGA Grieshaber KG
Am Hohenstein 113
77761 Schiltach
Germany

Phone +49 7836 50-0
E-mail: info.de@vega.com
www.vega.com