

Operating Instructions

Electronics module

SOLITRAC, MINITRAC, POINTRAC,
WEIGHTRAC



Document ID: 40104



VEGA

Contents

1	About this document	3
1.1	Function	3
1.2	Target group	3
1.3	Symbols used.....	3
2	For your safety	4
2.1	Authorised personnel	4
2.2	Appropriate use.....	4
2.3	Approvals	4
2.4	Environmental instructions	4
3	Product description	5
3.1	Configuration	5
3.2	Principle of operation.....	5
3.3	Packaging, transport and storage.....	5
4	Mounting	7
4.1	General instructions	7
4.2	Mounting preparations	7
4.3	Installation procedure	10
5	Setup	20
5.1	Setup preparations	20
5.2	Setup steps	20
6	Maintenance	21
6.1	How to proceed if a repair is necessary	21
7	Dismount	22
7.1	Dismounting steps.....	22
7.2	Disposal	22
8	Supplement	23
8.1	Technical data	23
8.2	Industrial property rights	24
8.3	Trademark	24

1 About this document

1.1 Function

This instruction provides all the information you need for mounting, connection and setup as well as important instructions for maintenance, fault rectification, the exchange of parts and the safety of the user. Please read this information before putting the instrument into operation and keep this manual accessible in the immediate vicinity of the device.

1.2 Target group

This operating instructions manual is directed to trained personnel. The contents of this manual must be made available to the qualified personnel and implemented.

1.3 Symbols used



Document ID

This symbol on the front page of this instruction refers to the Document ID. By entering the Document ID on www.vega.com you will reach the document download.



Information, note, tip: This symbol indicates helpful additional information and tips for successful work.



Note: This symbol indicates notes to prevent failures, malfunctions, damage to devices or plants.



Caution: Non-observance of the information marked with this symbol may result in personal injury.



Warning: Non-observance of the information marked with this symbol may result in serious or fatal personal injury.



Danger: Non-observance of the information marked with this symbol results in serious or fatal personal injury.



Ex applications

This symbol indicates special instructions for Ex applications.



List

The dot set in front indicates a list with no implied sequence.



Sequence of actions

Numbers set in front indicate successive steps in a procedure.



Battery disposal

This symbol indicates special information about the disposal of batteries and accumulators.

2 For your safety

2.1 Authorised personnel

All procedures described in this documentation must only be carried out by VEGA service technicians or qualified personnel that have received training from VEGA (e.g. VEGA sales partners).

During work on and with the device, the required personal protective equipment must always be worn.

2.2 Appropriate use

The components described in this manual are replacement components for existing sensors.

2.3 Approvals

If the instrument comes with approvals, the associated approval documents of the sensor must always be noted. They are included with the delivery but can also be downloaded under www.vega.com via "[VEGA Tools](#)" and "[Search](#)" as well as via "[Downloads](#)" and "[Approvals](#)".

2.4 Environmental instructions

Protection of the environment is one of our most important duties. That is why we have introduced an environment management system with the goal of continuously improving company environmental protection. The environment management system is certified according to DIN EN ISO 14001.

Please help us fulfil this obligation by observing the environmental instructions in this manual:

- Chapter "*Packaging, transport and storage*"
- Chapter "*Disposal*"

3 Product description

3.1 Configuration

Scope of this operating instructions

This operating instructions manual applies to the electronics modules of the following sensors from the PROTRAC series.

- SOLITRAC
- MINITRAC
- POINTRAC
- WEIGHTRAC

Scope of delivery

The scope of delivery encompasses:

- Electronics module
- Optical pad
- Plastic spatula
- Special grease for optical pad (tube 5 ml)
- Coded pins for mounting support (2 pcs.)
- Documentation
 - This operating instructions manual

3.2 Principle of operation

Application area

The electronics module is suitable for exchange in sensors of the PROTRAC series. You can find information of the available versions in chapter "*Mounting preparations*".

3.3 Packaging, transport and storage

Packaging

Your instrument was protected by packaging during transport. Its capacity to handle normal loads during transport is assured by a test based on ISO 4180.

The packaging consists of environment-friendly, recyclable cardboard. For special versions, PE foam or PE foil is also used. Dispose of the packaging material via specialised recycling companies.

Transport

Transport must be carried out in due consideration of the notes on the transport packaging. Nonobservance of these instructions can cause damage to the device.

Transport inspection

The delivery must be checked for completeness and possible transit damage immediately at receipt. Ascertained transit damage or concealed defects must be appropriately dealt with.

Storage

Up to the time of installation, the packages must be left closed and stored according to the orientation and storage markings on the outside.

Unless otherwise indicated, the packages must be stored only under the following conditions:

- Not in the open
- Dry and dust free
- Not exposed to corrosive media
- Protected against solar radiation

Storage and transport temperature

- Avoiding mechanical shock and vibration
- Storage and transport temperature see chapter " *Supplement - Technical data - Ambient conditions*"
- Relative humidity 20 ... 85 %

Lifting and carrying

With instrument weights of more than 18 kg (39.68 lbs) suitable and approved equipment must be used for lifting and carrying.

4 Mounting

4.1 General instructions

Safety during mounting

We recommended installing the replacement electronics with the instrument dismantled and brought to a suitable place, e.g. a workshop. If it is not possible to dismantle the instrument, the electronics module can also be installed on site at the measuring point.



Warning:

Switch off voltage supply before starting the installation procedure. The replacement electronics may only be installed when the sensor is in a **de-energised state**. Non-observance will damage the electronics!

Ex approval

It is absolutely necessary that the following points are observed with sensors with Ex approval:



For sensors with Ex approval, make sure that the replacement electronics module has the same designation as the exchanged electronics module.

For example, an electronics module with a hardware version $\geq 2.0.0$ must be only installed in a sensor with hardware version $\geq 2.0.0$.

4.2 Mounting preparations

Assignment

The electronics modules are mounted in the electronics compartment and adapted to the respective sensor. First of all, check by means of the following lists if you are using a suitable electronics module.

SOLITRAC, POINTRAC, WEIGHTRAC

- PT30E.SV for version four-wire 4 ... 20 mA/HART
- PT30E.SS for version 4 ... 20 mA/HART with SIL qualification
- PT30E.SP for version Foundation Fieldbus and Profibus PA

MINITRAC

- PT30E.MV for version four-wire 4 ... 20 mA/HART
- PT30E.MS for version 4 ... 20 mA/HART with SIL qualification
- PT30E.MP for version Foundation Fieldbus and Profibus PA

Order with pre-configured electronics module

If you ordered a pre-configured electronics module (with serial number), the serial number of your sensor has already been entered in the software of the electronics module.

See also chapter "Setup".



With SIL-qualified instruments, only corresponding electronics modules with SIL qualification may be used. Furthermore, only pre-configured electronics modules (with serial number) may be used.

Electronics modules for SIL qualified instruments can only be ordered by stating the sensor serial number. Have the sensor serial number ready when ordering.

Compare the sensor serial number on the electronics module with the sensor serial number on the type label of your sensor.

Check if this sensor serial number is also displayed when switching on the instrument. The sensor serial number can be displayed in the display and adjustment module or in the adjustment software PACTware.

The electronics module is also provided with its own electronics serial number. This number is only used for internal processes.

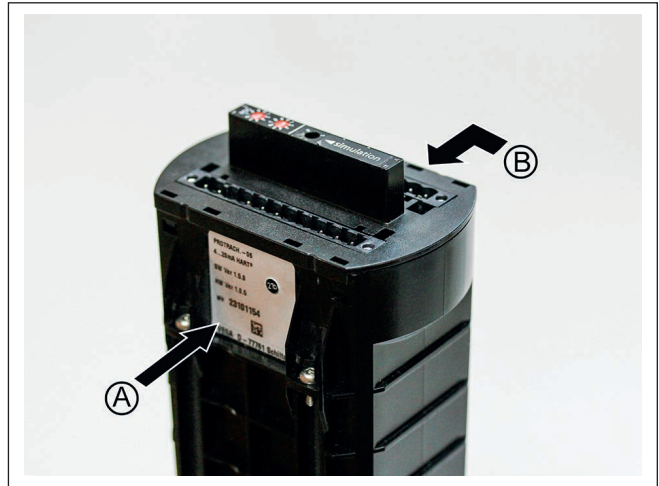

Fig. 1: Electronics serial number

- A Electronics serial number
- B Sensor serial number

Profibus PA

The supplied electronics module must be modified for Profibus PA instruments.

Remove the black cover foil above the two address selection switches for Profibus PA.

See the following illustration.



Fig. 2: Profibus PA - Remove the cover foil above the address selection switches

Coding

To prevent accidental use of a non-permissible electronics module, the terminal blocks are coded.

On the opposite side, you must code the electronics module according to your sensor.

To allow easier handling, the coded pins are mounted on a plastic plate. Two of these mounting supports are enclosed with the electronics module.

In the following illustration there is an example of a sensor coded without Ex approval (coding pin in terminal 4).

There is already a coding pin in terminal 2. This coding prevents the two terminal blocks from being exchanged.

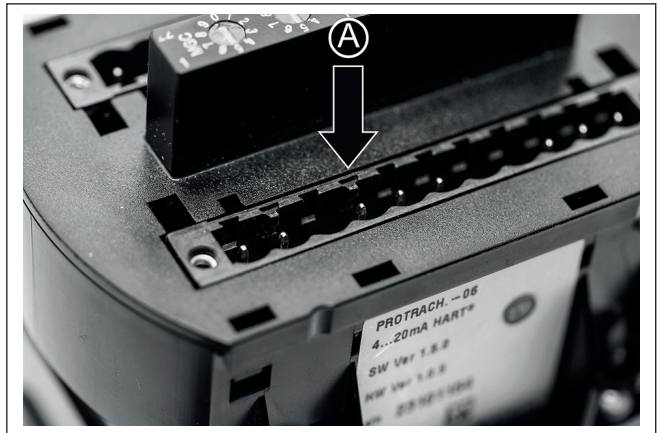

Fig. 3: Inserted coding pin

A Coding pin (e.g. for a sensor without approval)

You must code your sensor according to the new electronics module of your sensor.

- Terminal 3 - Sensors with Ex approval intrinsically safe (ia)
- Terminal 4 - Non-intrinsically safe sensors or sensors without approval

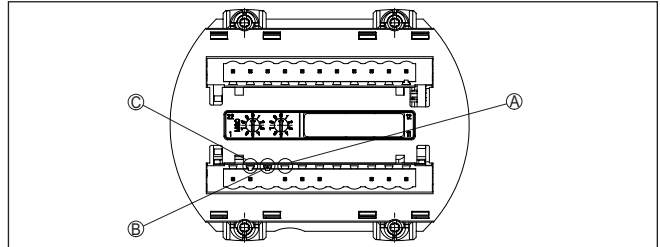

Fig. 4: Coding

- A Coding pin for non-intrinsically safe sensors and sensors without approval (terminal 4)
 B Coding pin for intrinsically safe (ia) instruments (terminal 3)
 C Coding pin - avoids an interchanging of the two terminal blocks (terminal 2)

To simplify handling, the small coding pins are attached to a plastic washer.

Insert one small coding pin into the dovetail guide until it snaps in. Then you can break off the mounting support.

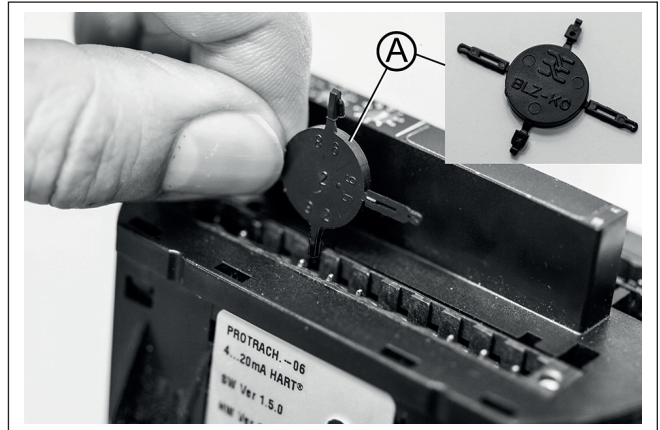

Fig. 5: Insert the coding pins into the electronics module

- A Coding pin on mounting support

4.3 Installation procedure



Caution:

Generally inform the radiation safety office before starting work on radiometric sensors and source containers. The radiation safety office must also be informed when exchanging the electronics module.

Keep in mind that the following work must only be carried out after an appropriate training from VEGA.

Proceed as follows:

1. Switch off the source reliably - Set the source container to "Off"
Secure radiation source from being switched on again.



Warning:

Always switch off the radiation source when working on the sensor and secure it against unauthorized or unintentional switching on.

2. Switch off voltage supply



Warning:

Connect only in a voltage-free state. Switch off the voltage supply reliably and secure it against unauthorized or unintentional switching on.

3. Carry out all work in a clean and dust-free environment. If possible, dismount the sensor.



Caution:

The black rubber protective cap protects the light-sensitive photomultiplier against incident light. Only remove the protective cap when you are requested to do so in this manual.

4. Check if all parts are included:
 - Optical pad
 - Plastic spatula
 - Special grease (tube)
 - Coded pins on mounting support (2 pcs.)
5. Unscrew cover (1) of the electronics compartment (5)
6. Loosen and detach the terminal blocks (6) of the old electronics module on the lateral "clamping brackets" (terminal blocks not included in the delivery)



Fig. 6: Electronics module in the housing

A Locking of the terminal blocks

6 Terminal blocks

7. Loosen the four holding screws (7) of the electronics module with a screwdriver (Torx size T 10)
8. Slowly pull out the old electronics module (2) so that the optical pad (4) can peel away from the glass window (9).

During this process, the photomultiplier (8) can get stuck inadvertently in the housing. In such case, push the photomultiplier back into the electronics module.

Keep the position of the plug connections inside the electronics module in mind (take note of the gap in the base and the corresponding pins)

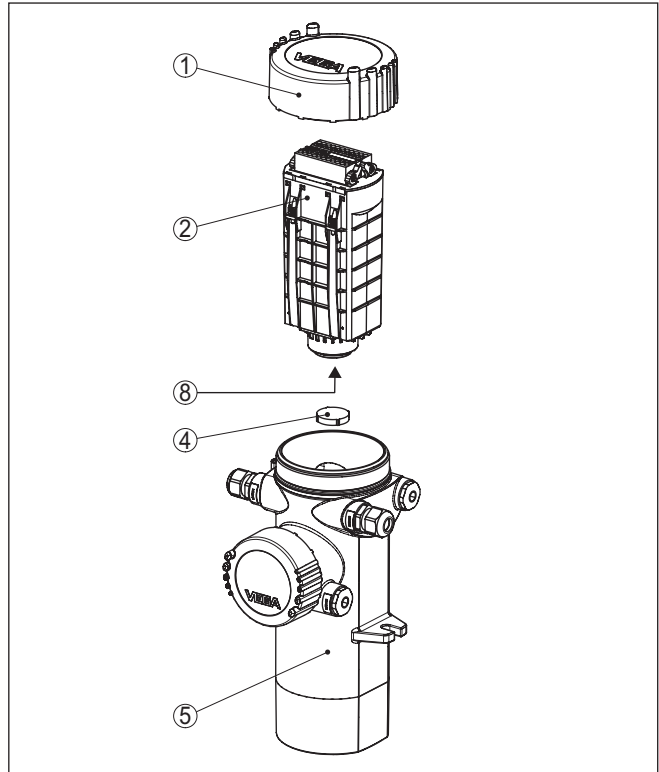

Fig. 7: Loosen the holding screws

- 1 Housing lid
- 2 Electronics module
- 4 Optical pad
- 5 Instrument housing
- 8 Photomultiplier

9. The optical pad (4) can stick to the round glass window at the bottom in the housing. In this case, use a small screwdriver to remove the optical pad (4) carefully. If you have small, slender hands, you can remove the optical pad (4) using just your hands.
10. Dispose of the old optical pad (4)
11. Clean the glass window (9) at the bottom of the housing with a lint-free cloth. Do not use any cleaning agents. See following illustration.

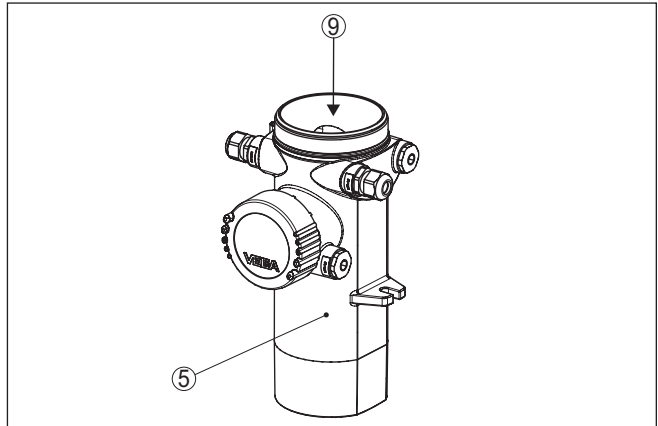

Fig. 8: Clean the glass window in the instrument housing

- 5 Instrument housing
- 9 Glass window

12. Check if all parts are dry, clean and dust-free.
13. Open the attached tube of special grease (10).
14. Apply special grease (10) to one side of the new optical pad (4).
See the following illustration.

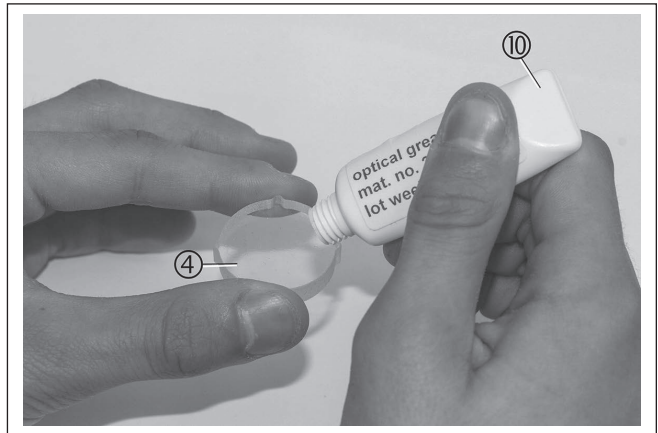

Fig. 9: Apply special grease to one side of the optical pad

- 4 Optical pad
- 10 Special grease

15. Use the edge of the plastic spatula (11) to skim the surface of the optical pad (4) so that only a wafer-thin grease film remains. See the following illustration.

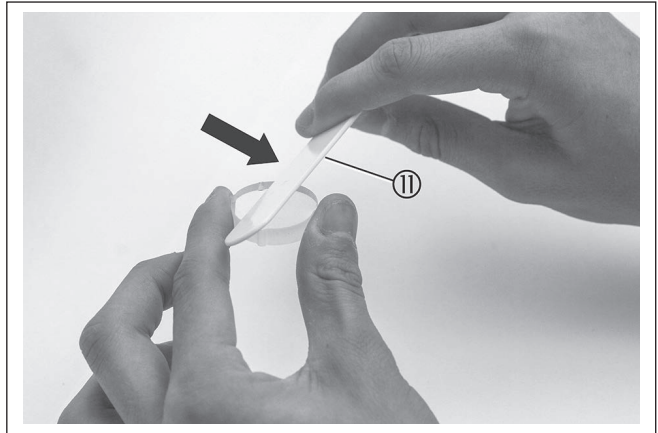

Fig. 10: Skim the surface of the the optical pad with the plastic spatula

11 Plastic spatula

16. Detach the protective cap with the foam rubber pad (3) from the photomultiplier (8) of the new electronics module.

Avoid exposing the photomultiplier to direct light. Detach the protective cap (3) only as the final step.

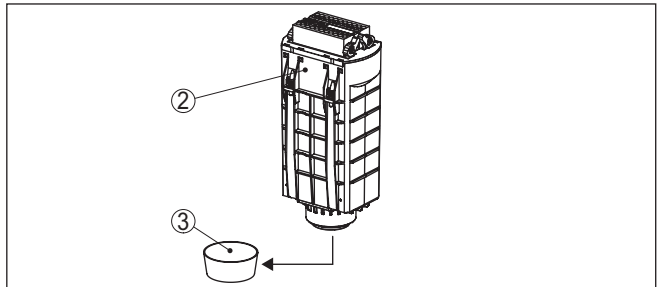

Fig. 11: Detach the protective cap with the foam rubber pad

2 Electronics module

3 Protective cap with foam rubber pad

17. Check if the photomultiplier (8) of the new electronics module is clean. If necessary clean with a lint-free cloth. See illustration.

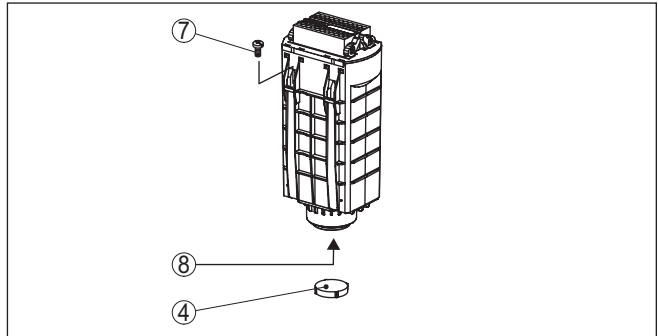

Fig. 12: Check the photomultiplier

- 4 Optical pad
- 7 Holding screws
- 8 Photomultiplier

18. Place the optical pad (4) with the greased side centered to the photomultiplier (8).

Do not press with your fingers or sharp objects.

19. Apply special grease to the second side of the optical pad. See following illustration.

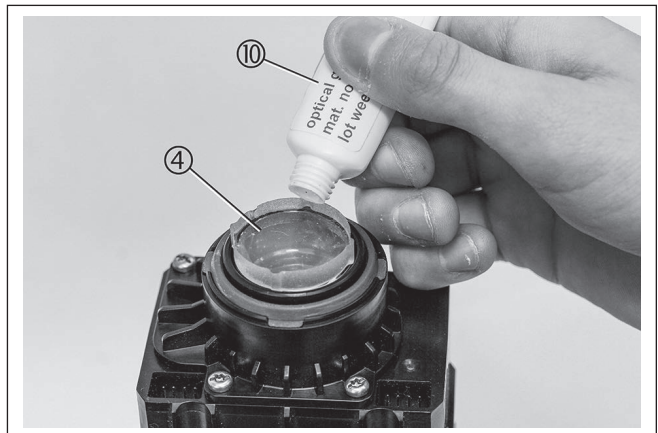

Fig. 13: Apply special grease to the second side of the optical pad

- 4 Optical Pad
- 10 Special grease

20. Use the edge of the plastic spatula (11) to skim the surface of the optical pad (4) so that only a wafer-thin grease film remains. See the following illustration.

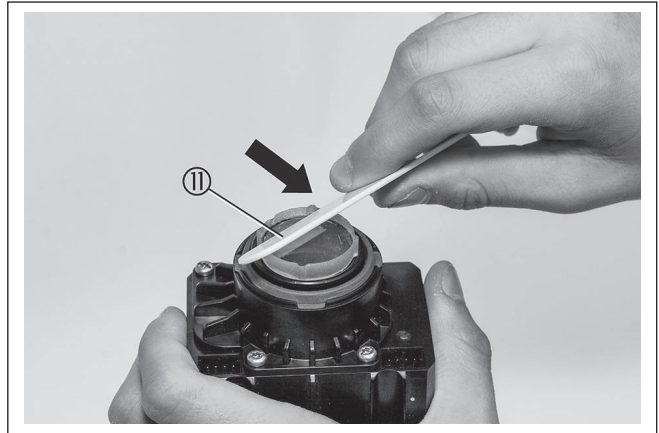

Fig. 14: Skim the second side of the optical pad with the plastic spatula

11 Plastic spatula

21. Insert the new electronics module (2) carefully into the instrument housing (5)

Take note of the correct direction when inserting the electronics module. The electronics module cannot be inserted the wrong way. Keep the plugs on the lower side in mind.

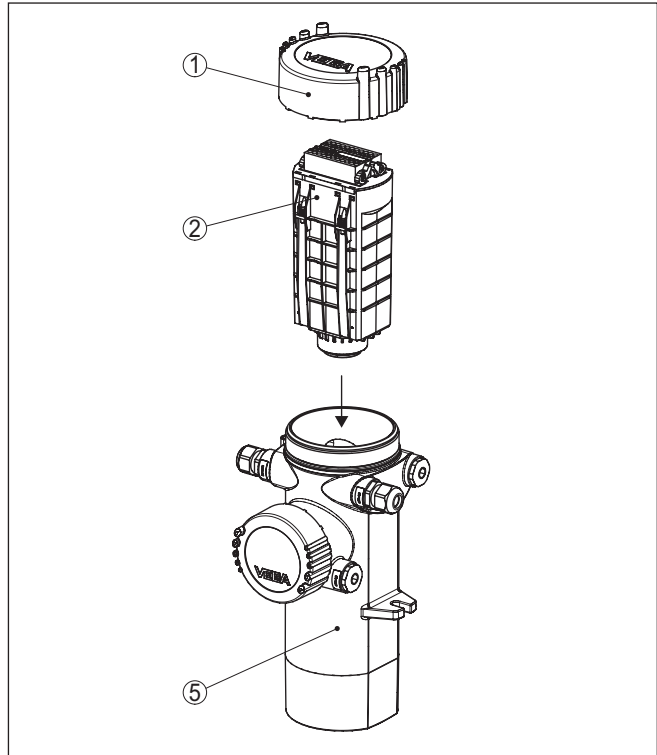

Fig. 15: Insert the electronics module carefully into the instrument housing.

- 1 Housing lid
- 2 Electronics module
- 5 Instrument housing



Note:

If the optical pad (4) drops out when inserting the electronics module, you have to clean the optical pad (4) carefully, grease it again, remove the grease (only a thin film should remain) and place it again onto the photomultiplier (8).

- 22. Press the electronics module (2) carefully down onto the plug connections.
- 23. Tighten the four holding screws (7)
- 24. Plug the already connected terminal blocks (6) carefully onto the new electronics module (2).



Note:

The terminal blocks are uniquely coded according to the electronics version.

If one of the terminal blocks does not fit onto the electronics module, check if you are using the right electronics module.

If the electronics module is correct, check the coding.

See chapter " *Mounting preparations*".

25. Screw the housing cover onto the housing up to the stop and protect it against unintentional opening by screwing out the hexagon screw.



Note:

If the photomultiplier was exposed to strong light, this can temporarily cause measurement deviations. Therefore, as a rule, wait two hours before you put the instrument into operation.

The electronics exchange is now finished.



As a rule, an exchange of electronics must be documented internally if SIL qualified instruments are involved.



As a rule, an exchange of electronics must be documented internally if Ex applications are involved.



Information:

The old electronics module is not contaminated and can be disposed of as electronic scrap.

5 Setup

5.1 Setup preparations

With sensor serial number

If you ordered the electronics module **by stating the sensor serial number**, it is ready for the setup procedure immediately after installation and connection to power supply.



Electronics modules for SIL qualified instruments can only be ordered by stating the sensor serial number.

Electronics module without programming

If you ordered the electronics module **without programming** or you are using a suitable electronics module from stock, you first have to load the instrument data after the installation.

The instrument data also include the TAG no., information on the process fitting and seal as well as activation data for a supplementary electronics.

Enter the serial number of your device into the search field on our homepage "www.vega.com".

After entering the serial number, the order data of the device are displayed.

Under "*Related documentation*" you will find "*Sensor for electronics exchange*" as an XML file. Save this DTM configuration file with "*Save as*" on your PC and transfer it via PACTware and the Service DTM to the instrument.

5.2 Setup steps

Parameter adjustment

If the instrument is used in the same application after the electronics exchange, the previous parameter settings of the instrument must be restored. To do this, you can use the import function of the adjustment software PACTware with the device DTMs or the copy function of the display and adjustment module.

If no copy of the parameter settings is available, you have to carry out a fresh setup. See the operating instructions of the sensor.



On SIL qualified instruments, the settings of the electronics must be checked and verified after the electronics exchange. Only then is the instrument again ready for operation.

6 Maintenance

6.1 How to proceed if a repair is necessary

You can find an instrument return form as well as detailed information about the procedure in the download area of our homepage. By doing this you help us carry out the repair quickly and without having to call back for needed information.

In case of repair, proceed as follows:

- Print and fill out one form per instrument
- Clean the instrument and pack it damage-proof
- Attach the completed form and, if need be, also a safety data sheet outside on the packaging
- Ask the agency serving you to get the address for the return shipment. You can find the agency on our homepage.

7 Dismount

7.1 Dismounting steps

**Warning:**

Before dismantling, be aware of dangerous process conditions such as e.g. pressure in the vessel or pipeline, high temperatures, corrosive or toxic media etc.

Take note of chapters "*Mounting*" and "*Connecting to voltage supply*" and carry out the listed steps in reverse order.

7.2 Disposal

The instrument consists of materials which can be recycled by specialised recycling companies. We use recyclable materials and have designed the electronics to be easily separable.

WEEE directive

The instrument does not fall in the scope of the EU WEEE directive. Article 2 of this Directive exempts electrical and electronic equipment from this requirement if it is part of another instrument that does not fall in the scope of the Directive. These include stationary industrial plants.

Pass the instrument directly on to a specialised recycling company and do not use the municipal collecting points.

If you have no way to dispose of the old instrument properly, please contact us concerning return and disposal.

8 Supplement

8.1 Technical data

Technical data

The technical data are listed in the operating instructions manual of the respective device.

8.2 Industrial property rights

VEGA product lines are global protected by industrial property rights. Further information see www.vega.com.

VEGA Produktfamilien sind weltweit geschützt durch gewerbliche Schutzrechte.

Nähere Informationen unter www.vega.com.

Les lignes de produits VEGA sont globalement protégées par des droits de propriété intellectuelle. Pour plus d'informations, on pourra se référer au site www.vega.com.

VEGA lineas de productos están protegidas por los derechos en el campo de la propiedad industrial. Para mayor información revise la pagina web www.vega.com.

Линии продукции фирмы ВЕГА защищаются по всему миру правами на интеллектуальную собственность. Дальнейшую информацию смотрите на сайте www.vega.com.

VEGA系列产品在全球享有知识产权保护。

进一步信息请参见网站 < www.vega.com。

8.3 Trademark

All the brands as well as trade and company names used are property of their lawful proprietor/originator.







Printing date:

VEGA

All statements concerning scope of delivery, application, practical use and operating conditions of the sensors and processing systems correspond to the information available at the time of printing.

Subject to change without prior notice

© VEGA Grieshaber KG, Schiltach/Germany 2021



40104-EN-210107

VEGA Grieshaber KG
Am Hohenstein 113
77761 Schiltach
Germany

Phone +49 7836 50-0
Fax +49 7836 50-201
E-mail: info.de@vega.com
www.vega.com