

Operating Instructions

Vibrating level switch with suspension cable for powders

VEGAWAVE 62

Two-wire 8/16 mA



Document ID: 32255



VEGA

Contents

1	About this document	4
1.1	Function	4
1.2	Target group	4
1.3	Symbols used	4
2	For your safety	5
2.1	Authorised personnel	5
2.2	Appropriate use	5
2.3	Warning about incorrect use	5
2.4	General safety instructions	5
2.5	Safety label on the instrument	6
2.6	Conformity	6
2.7	SIL conformity	6
2.8	Installation and operation in the USA and Canada	6
2.9	Safety instructions for Ex areas	6
2.10	Environmental instructions	6
3	Product description	7
3.1	Configuration	7
3.2	Principle of operation	8
3.3	Adjustment	8
3.4	Storage and transport	9
4	Mounting	10
4.1	General instructions	10
4.2	Mounting instructions	11
5	Connecting to power supply	16
5.1	Preparing the connection	16
5.2	Connection procedure	16
5.3	Wiring plan, single chamber housing	17
5.4	Wiring plan - version IP66/IP68, 1 bar	19
6	Setup	20
6.1	General information	20
6.2	Adjustment elements	20
6.3	Function table	21
6.4	Proof test (SIL)	23
7	Maintenance and fault rectification	27
7.1	Maintenance	27
7.2	Rectify faults	27
7.3	Exchanging the electronics module	28
7.4	How to proceed if a repair is necessary	29
8	Dismount	31
8.1	Dismounting steps	31
8.2	Disposal	31
9	Supplement	32
9.1	Technical data	32
9.2	Dimensions	35
9.3	Industrial property rights	39

9.4 Trademark	39
---------------------	----



Safety instructions for Ex areas:

Take note of the Ex specific safety instructions for Ex applications. These instructions are attached as documents to each instrument with Ex approval and are part of the operating instructions.

Editing status: 2022-09-15

1 About this document

1.1 Function

This instruction provides all the information you need for mounting, connection and setup as well as important instructions for maintenance, fault rectification, the exchange of parts and the safety of the user. Please read this information before putting the instrument into operation and keep this manual accessible in the immediate vicinity of the device.

1.2 Target group

This operating instructions manual is directed to trained personnel. The contents of this manual must be made available to the qualified personnel and implemented.

1.3 Symbols used



Document ID

This symbol on the front page of this instruction refers to the Document ID. By entering the Document ID on www.vega.com you will reach the document download.



Information, note, tip: This symbol indicates helpful additional information and tips for successful work.



Note: This symbol indicates notes to prevent failures, malfunctions, damage to devices or plants.



Caution: Non-observance of the information marked with this symbol may result in personal injury.



Warning: Non-observance of the information marked with this symbol may result in serious or fatal personal injury.



Danger: Non-observance of the information marked with this symbol results in serious or fatal personal injury.



Ex applications

This symbol indicates special instructions for Ex applications.



List

The dot set in front indicates a list with no implied sequence.



Sequence of actions

Numbers set in front indicate successive steps in a procedure.



Disposal

This symbol indicates special instructions for disposal.

2 For your safety

2.1 Authorised personnel

All operations described in this documentation must be carried out only by trained, qualified personnel authorised by the plant operator. During work on and with the device, the required personal protective equipment must always be worn.

2.2 Appropriate use

The VEGAWAVE 62 is a sensor for point level detection.

You can find detailed information about the area of application in chapter " *Product description*".

Operational reliability is ensured only if the instrument is properly used according to the specifications in the operating instructions manual as well as possible supplementary instructions.

For safety and warranty reasons, any invasive work on the device beyond that described in the operating instructions manual may be carried out only by personnel authorised by the manufacturer. Arbitrary conversions or modifications are explicitly forbidden.

2.3 Warning about incorrect use

Inappropriate or incorrect use of this product can give rise to application-specific hazards, e.g. vessel overflow through incorrect mounting or adjustment. Damage to property and persons or environmental contamination can result. Also, the protective characteristics of the instrument can be impaired.

2.4 General safety instructions

This is a state-of-the-art instrument complying with all prevailing regulations and directives. The instrument must only be operated in a technically flawless and reliable condition. The operator is responsible for the trouble-free operation of the instrument. When measuring aggressive or corrosive media that can cause a dangerous situation if the instrument malfunctions, the operator has to implement suitable measures to make sure the instrument is functioning properly.

The safety instructions in this operating instructions manual, the national installation standards as well as the valid safety regulations and accident prevention rules must be observed by the user.

For safety and warranty reasons, any invasive work on the device beyond that described in the operating instructions manual may be carried out only by personnel authorised by the manufacturer. Arbitrary conversions or modifications are explicitly forbidden. For safety reasons, only the accessory specified by the manufacturer must be used.

To avoid any danger, the safety approval markings and safety tips on the device must also be observed.

2.5 Safety label on the instrument

The safety approval markings and safety tips on the device must be observed.

2.6 Conformity

The device complies with the legal requirements of the applicable country-specific directives or technical regulations. We confirm conformity with the corresponding labelling.

The corresponding conformity declarations can be found on our homepage.

2.7 SIL conformity

VEGAWAVE 62 meets the requirements to the functional safety according to IEC 61508. Further information is available in the Safety Manual "VEGAWAVE series 60".

2.8 Installation and operation in the USA and Canada

This information is only valid for USA and Canada. Hence the following text is only available in the English language.

Installations in the US shall comply with the relevant requirements of the National Electrical Code (ANSI/NFPA 70).

Installations in Canada shall comply with the relevant requirements of the Canadian Electrical Code.

2.9 Safety instructions for Ex areas

For applications in explosion-proof areas (Ex), only devices with corresponding Ex approval may be used. Observe the Ex-specific safety instructions. These are an integral part of the operating instructions and are enclosed with every device with Ex approval.

2.10 Environmental instructions

Protection of the environment is one of our most important duties. That is why we have introduced an environment management system with the goal of continuously improving company environmental protection. The environment management system is certified according to DIN EN ISO 14001.

Please help us fulfil this obligation by observing the environmental instructions in this manual:

- Chapter "Packaging, transport and storage"
- Chapter "Disposal"

3 Product description

3.1 Configuration

Scope of delivery

The scope of delivery encompasses:

- VEGAWAVE 62 point level switch
- Documentation
 - This operating instructions manual
 - Safety Manual "*Functional safety (SIL)*" (optional)
 - Supplementary instructions manual "*Plug connector for level sensors*" (optional)
 - Ex-specific "*Safety instructions*" (with Ex versions)
 - If necessary, further certificates

Constituent parts

The VEGAWAVE 62 consists of the components:

- Housing lid
- Housing with electronics
- Process fitting with tuning fork

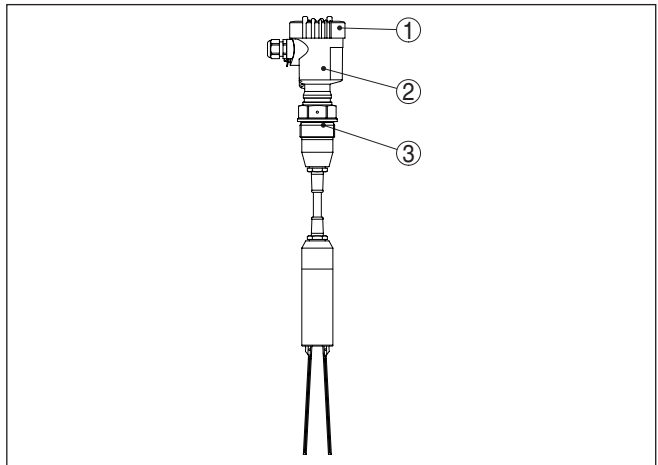

Fig. 1: VEGAWAVE 62 with plastic housing

- 1 Housing lid
- 2 Housing with electronics
- 3 Process fitting

Type label

The type label contains the most important data for identification and use of the instrument:

- Article number
- Serial number
- Technical data
- Article numbers, documentation
- SIL identification (with SIL rating ex works)

With the serial number, you can access the delivery data of the instrument via "www.vega.com", "*Search*". You can find the serial number

on the inside of the instrument as well as on the type label on the outside.

3.2 Principle of operation

Application area

VEGAWAVE 62 is a point level sensor with tuning fork for point level detection.

It is designed for industrial use in all areas of process technology and is preferably used for bulk solids.

Typical applications are overflow and dry run protection. Thanks to its simple and robust measuring system, VEGAWAVE 62 is virtually unaffected by the chemical and physical properties of the bulk solid.

It also works when subjected to strong external vibrations or changing products.

Solid detection in water

If VEGAWAVE 62 was ordered for solids detection in water, the tuning fork is set to the density of water. In air or when immersed in water (density: 1 g/cm³/0.036 lbs/in), VEGAWAVE 62 signals "uncovered". Only when the vibrating element is also covered with solids (e.g. sand, sludge, gravel etc.) will the sensor signal "covered".

Function monitoring

The electronics module of VEGAWAVE 62 continuously monitors the following criteria:

- Correct vibrating frequency
- Line break to the piezo drive

If one of these faults is detected, the electronics signals this via a defined current to the controller. The connection cable to the vibrating element is also monitored.

Functional principle

The tuning fork is piezoelectrically energised and vibrates at its mechanical resonance frequency of approx. 150 Hz. When the tuning fork is submerged in the product, the vibration amplitude changes. This change is detected by the integrated electronics module and converted into a switching command.

Voltage supply

Depending on your requirements, VEGAWAVE 62 with two-wire electronics can be connected to different controllers. Compatible controllers are listed in chapter " *Technical data*".

The data for power supply are specified in chapter " *Technical data*".

3.3 Adjustment

On the electronics module you will find the following display and adjustment elements:

- Signal lamp for indication of the switching condition (green/red)
- Potentiometer for adaptation to the product density
- Mode changeover for selection of the output current

3.4 Storage and transport

Packaging	<p>Your instrument was protected by packaging during transport. Its capacity to handle normal loads during transport is assured by a test based on ISO 4180.</p> <p>The packaging of standard instruments consists of environment-friendly, recyclable carton material. The sensing element is additionally protected with a cardboard cover. For special versions, PE foam or PE foil is also used. Please dispose of the packaging material through specialised recycling companies.</p>
Transport	<p>Transport must be carried out in due consideration of the notes on the transport packaging. Nonobservance of these instructions can cause damage to the device.</p>
Transport inspection	<p>The delivery must be checked for completeness and possible transit damage immediately at receipt. Ascertained transit damage or concealed defects must be appropriately dealt with.</p>
Storage	<p>Up to the time of installation, the packages must be left closed and stored according to the orientation and storage markings on the outside.</p> <p>Unless otherwise indicated, the packages must be stored only under the following conditions:</p> <ul style="list-style-type: none">● Not in the open● Dry and dust free● Not exposed to corrosive media● Protected against solar radiation● Avoiding mechanical shock and vibration
Storage and transport temperature	<ul style="list-style-type: none">● Storage and transport temperature see chapter " <i>Supplement - Technical data - Ambient conditions</i>"● Relative moisture 20 ... 85 %
Lifting and carrying	<p>With instrument weights of more than 18 kg (39.68 lbs) suitable and approved equipment must be used for lifting and carrying.</p>

4 Mounting

4.1 General instructions

Process conditions



Note:

For safety reasons, the instrument must only be operated within the permissible process conditions. You can find detailed information on the process conditions in chapter " *Technical data*" of the operating instructions or on the type label.

Hence make sure before mounting that all parts of the instrument exposed to the process are suitable for the existing process conditions.

These are mainly:

- Active measuring component
- Process fitting
- Process seal

Process conditions in particular are:

- Process pressure
- Process temperature
- Chemical properties of the medium
- Abrasion and mechanical influences

Suitability for the ambient conditions

The instrument is suitable for standard and extended ambient conditions acc. to DIN/EN/IEC/ANSI/ISA/UL/CSA 61010-1. It can be used indoors as well as outdoors.

Switching point

In general, VEGAWAVE 62 must be mounted vertically. The instrument must be mounted in such a way that the vibrating element is at the height of the requested switching point.

Moisture

Use the recommended cables (see chapter " *Connecting to power supply*") and tighten the cable gland.

You can give your instrument additional protection against moisture penetration by leading the connection cable downward in front of the cable gland. Rain and condensation water can thus drain off. This applies mainly to outdoor mounting as well as installation in areas where high humidity is expected (e.g. through cleaning processes) or on cooled or heated vessels.

To maintain the housing protection, make sure that the housing lid is closed during operation and locked, if necessary.

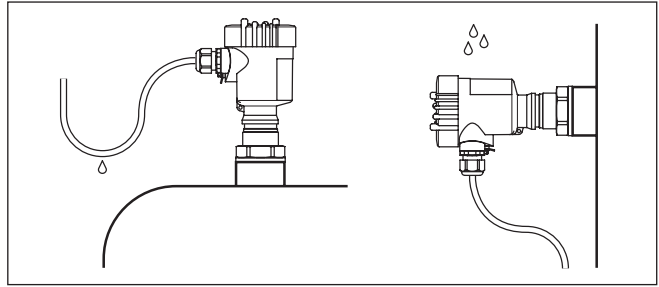

Fig. 2: Measures against moisture ingress

Transport

Do not hold VEGAWAVE 62 on the vibrating element. Especially with flange and tube versions, the sensor can be damaged by the weight of the instrument.

Remove the protective cover just before mounting.

Pressure/Vacuum

The process fitting must be sealed if there is gauge or low pressure in the vessel. Before use, check if the sealing material is resistant against the measured product and the process temperature.

The max. permissible pressure is specified in chapter " *Technical data*" or on the type label of the sensor.

Handling

The vibrating level switch is a measuring instrument and must be treated accordingly. Bending the vibrating element will destroy the instrument.



Warning:

The housing must not be used to screw the instrument in! Applying tightening force can damage internal parts of the housing.

Use the hexagon above the thread for screwing in.

**Cable entries - NPT thread
Cable glands**

Metric threads

In the case of instrument housings with metric thread, the cable glands are screwed in at the factory. They are sealed with plastic plugs as transport protection.

You have to remove these plugs before electrical connection.

NPT thread

In the case of instrument housings with self-sealing NPT threads, it is not possible to have the cable entries screwed in at the factory. The free openings for the cable glands are therefore covered with red dust protection caps as transport protection.

Prior to setup you have to replace these protective caps with approved cable glands or close the openings with suitable blind plugs.

4.2 Mounting instructions

Tensile load

Make sure that the max. permissible tensile load of the suspension cable is not exceeded. The danger of this happening exists particu-

larly with very heavy solids and large meas. lengths. The max. permissible load is stated in chapter " *Technical data*".

Material cone

In silos with bulk solids, material cones can form which change the switching point. Please keep this in mind when installing the sensor in the vessel. We recommend selecting an installation location where the sensor detects the average value of the material cone.

The tuning fork must be mounted in a way that takes the arrangement of the filling and emptying apertures into account.

To compensate measurement errors caused by the material cone in cylindrical vessels, the sensor must be mounted at a distance of $d/10$ from the vessel wall.

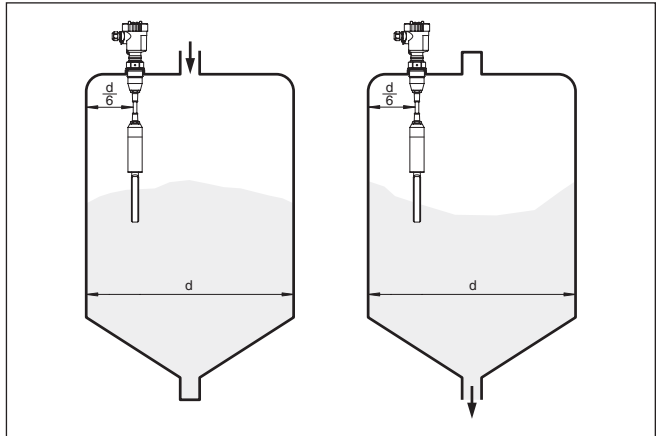

Fig. 3: Filling and emptying centred

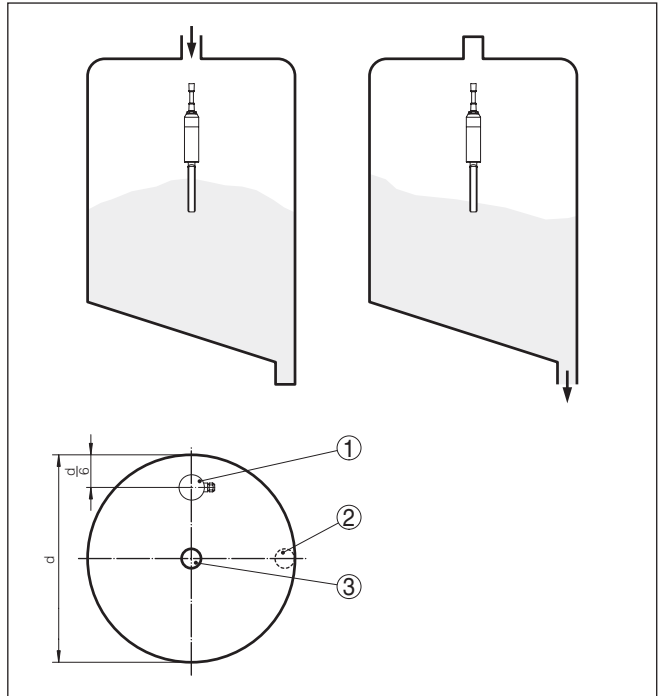

Fig. 4: Filling in the centre, emptying laterally

- 1 VEGAWAVE 62
- 2 Discharge opening
- 3 Filling opening

Nozzle

The vibrating element should protrude into the vessel to avoid buildup. For that reason, avoid using mounting bosses for flanges and screwed fittings. This applies particularly to use with adhesive products.

Inflowing medium

If VEGAWAVE 62 is mounted in the filling stream, unwanted false measurement signals can be generated. For this reason, mount VEGAWAVE 62 at a position in the vessel where no disturbances, e.g. from filling openings, agitators, etc., can occur.

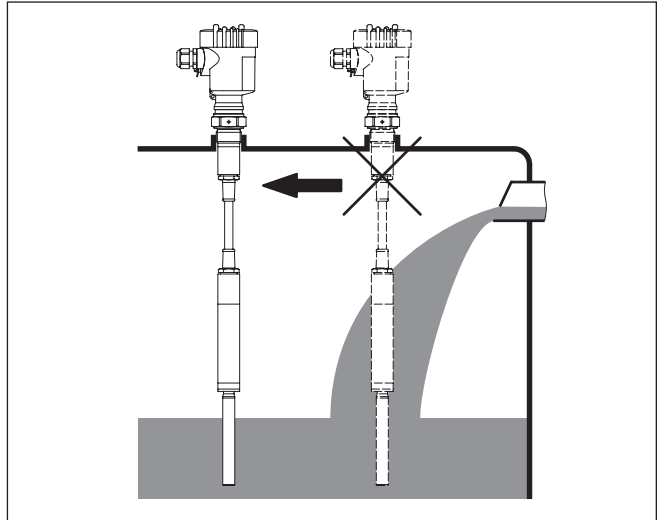

Fig. 5: Inflowing medium

Product flow

To make sure the tuning fork of VEGAWAVE 62 generates as little resistance as possible to product flow, mount the sensor so that the surfaces are parallel to the product movement.

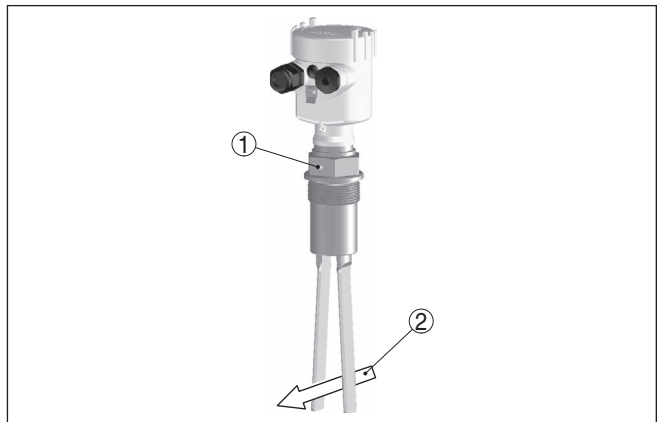

Fig. 6: Flow orientation of the tuning fork

- 1 Marking with screwed version
- 2 Direction of flow

Baffle protection against falling rocks

In applications such as grit chambers or settling basins for coarse sediments, the vibrating element must be protected against damage with a suitable baffle.

This baffle must be manufactured by you.

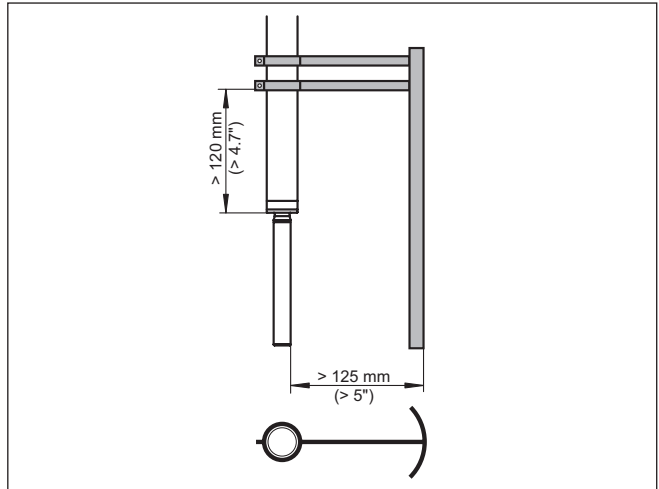

Fig. 7: Baffle for protection against mechanical damage

5 Connecting to power supply

5.1 Preparing the connection

Note safety instructions

Always keep in mind the following safety instructions:



Warning:

Connect only in the complete absence of line voltage.

- The electrical connection must only be carried out by trained, qualified personnel authorised by the plant operator.
- Always switch off power supply, before connecting or disconnecting the instrument.

Take note of safety instructions for Ex applications



In hazardous areas you must take note of the respective regulations, conformity and type approval certificates of the sensors and power supply units.

Voltage supply

Connect the voltage supply according to the following diagrams. Take note of the general installation regulations. As a rule, connect VEGA-WAVE 62 to vessel ground (PA), or in case of plastic vessels, to the next ground potential. On the side of the instrument housing there is a ground terminal between the cable entries. This connection serves to drain off electrostatic charges. In Ex applications, the installation regulations for hazardous areas must be given priority.

The data for power supply are specified in chapter " *Technical data*".

Connection cable

The instrument is connected with standard two-wire cable without shielding. If electromagnetic interference is expected which is above the test values of EN 61326 for industrial areas, shielded cable should be used.

Make sure that the cable used has the required temperature resistance and fire safety for max. occurring ambient temperature

Use cable with round cross-section. A cable outer diameter of 5 ... 9 mm (0.2 ... 0.35 in) ensures the seal effect of the cable gland. If you are using cable with a different diameter or cross-section, exchange the seal or use a suitable cable gland.



In hazardous areas, use only approved cable connections for VEGA-WAVE 62.

Connection cable for Ex applications



Take note of the corresponding installation regulations for Ex applications.

Cover all housing openings conforming to standard according to EN 60079-1.

5.2 Connection procedure



With Ex instruments, the housing cover may only be opened if there is no explosive atmosphere present.

Proceed as follows:

1. Unscrew the housing lid

2. Loosen compression nut of the cable gland and remove blind plug
3. Remove approx. 10 cm (4 in) of the cable mantle, strip approx. 1 cm (0.4 in) of insulation from the ends of the individual wires
4. Insert the cable into the sensor through the cable entry
5. Lift the opening levers of the terminals with a screwdriver (see following illustration)

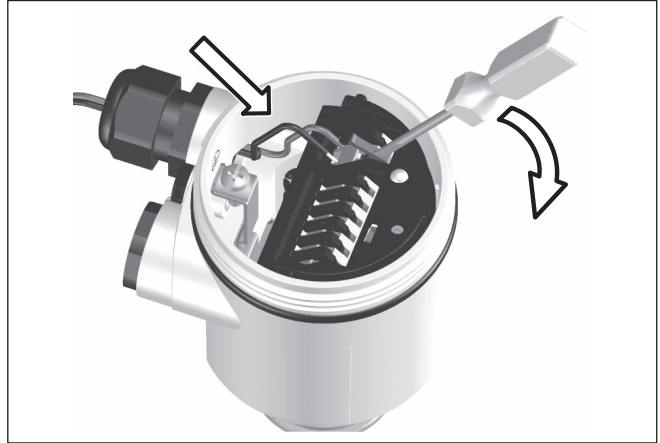

Fig. 8: Connection steps 5 and 6

6. Insert the wire ends into the open terminals according to the wiring plan
 7. Press down the opening levers of the terminals, you will hear the terminal spring closing
 8. Check the hold of the wires in the terminals by lightly pulling on them
 9. Tighten the compression nut of the cable entry gland. The seal ring must completely encircle the cable
 10. If necessary, carry out a fresh adjustment
 11. Screw the housing lid back on
- The electrical connection is finished.

5.3 Wiring plan, single chamber housing



The following illustrations apply to the non-Ex as well as to the Ex-d version.

Housing overview

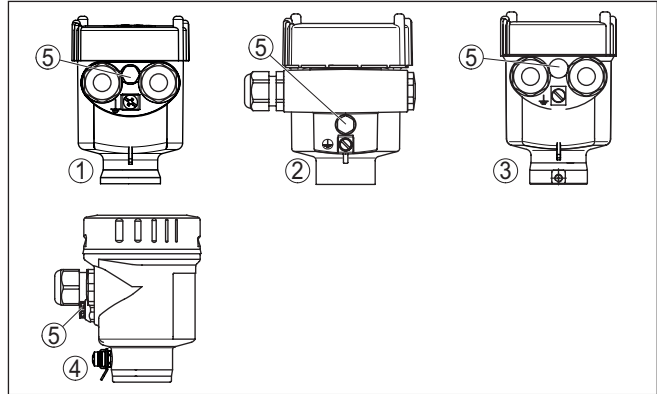

Fig. 9: Material versions, single chamber housing

- 1 Plastic (not with Ex d)
- 2 Aluminium
- 3 Stainless steel (not with Ex d)
- 4 Stainless steel, electropolished (not with Ex d)
- 5 Filter element for pressure compensation or blind plug with version IP 66/IP 68, 1 bar (not with Ex d)

Wiring plan

For connection to a controller. The sensor is powered via the connected controller. For further information see the "Technical data" in the "Supplement".

The wiring example is applicable for all suitable controllers.

If the mode switch of VEGAWAVE 62 is correctly set to "max.", the control lamp on VEGAWAVE 62 lights.

- red - with submerged vibrating element
- green - with uncovered vibrating element

Take note of the operating instructions manual of the controller. Suitable controllers are listed in chapter "Technical data".

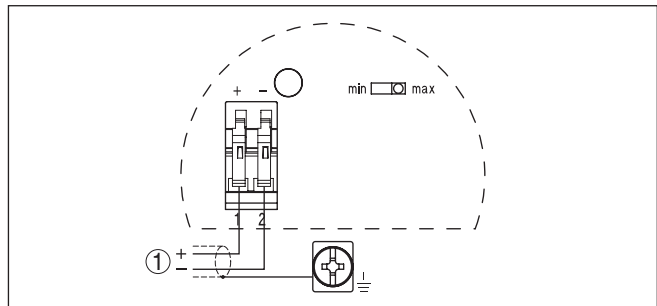

Fig. 10: Wiring plan

- 1 Voltage supply

5.4 Wiring plan - version IP66/IP68, 1 bar

Wire assignment, connection cable

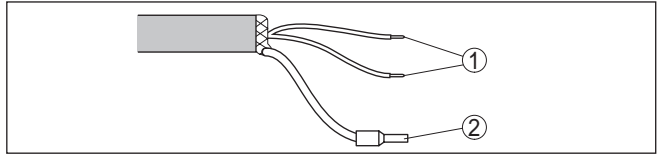

Fig. 11: Wire assignment, connection cable

- 1 Brown (+) and blue (-) to power supply or to the processing system
- 2 Shielding

6 Setup

6.1 General information

The figures in brackets refer to the following illustrations.

Function/Configuration

On the electronics module you will find the following display and adjustment elements:

- Potentiometer for adjustment of the density range (1)
- DIL switch for mode adjustment - min./max. (2)
- Signal lamp (5)



Note:

As a rule, always set the mode with mode switch (2) before starting the setup of VEGAWAVE 62. If the instrument is used in conjunction with a controller, always set the mode switch (2) on VEGAWAVE 62 to max. mode.

The mode is selected on the controller with the mode switch.

The switching output will change if you set one of the two mode switches afterwards. This could possibly trigger other connected instruments or devices.

Electronics and connection compartment

6.2 Adjustment elements

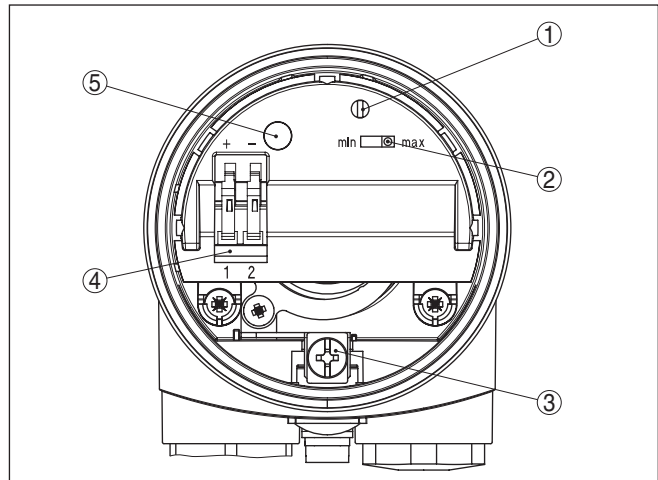

Fig. 12: Electronics and connection compartment - two-wire output

- 1 Potentiometer for adjustment of the density range
- 2 DIL switch for mode adjustment
- 3 Ground terminal
- 4 Connection terminals
- 5 Control lamp

Adjustment of the density range (1)

With the potentiometer you can adapt the switching point to the solid. It is already preset and must only be modified in special cases.

By default, the potentiometer of VEGAWAVE 62 is set to the right stop ($> 0.02 \text{ g/cm}^3$ or 0.0008 lbs/in^3). In case of very light-weight solids, turn the potentiometer to the left stop ($> 0.008 \text{ g/cm}^3$ or 0.0003 lbs/in^3). VEGAWAVE 62 will thus be more sensitive and can detect light-weight solids more reliably.

For instruments detecting solids in water, these settings are not applicable. The density range is preset and must not be changed.

Mode adjustment (2)

With the mode adjustment (min./max.) you can determine the output current.

When using a controller, always set the mode switch to max. mode. In this case, you select the requested mode according to the "Function table" (max. - max. detection or overflow protection, min. - min. detection or dry run detection) on the controller.

When used on a control system, the following values apply:

- Mode min.
 - Vibrating element uncovered - $16 \text{ mA} \pm 1 \text{ mA}$
 - Vibrating element covered - $8 \text{ mA} \pm 1 \text{ mA}$
- Mode max.
 - Vibrating element uncovered - $8 \text{ mA} \pm 1 \text{ mA}$
 - Vibrating element covered - $16 \text{ mA} \pm 1 \text{ mA}$

Signal lamp (5)





Control lamp for indication of the switching status





- green = 8 mA
- red = 16 mA
- red (flashing) = Failure ($< 2.3 \text{ mA}$)

6.3 Function table

Level switch VEGAWAVE 62

The following table provides an overview of the switching conditions depending on the set mode and the level.

Mode on the sensor	Level	Signal current - Sensor	Signal lamp - sensor
Max. Overflow protection		8 mA	 Green
Max. Overflow protection		approx. 16 mA	 Red













Mode on the sensor	Level	Signal current - Sensor	Signal lamp - sensor
Min. Dry run protection		approx. 8 mA	 Green
Min. Dry run protection		approx. 16 mA	 Red
Fault message (min./max. mode)	any	< 2.3 mA	 flashes red

VEGAWAVE 62 level switch with controller ¹⁾



The following table provides an overview of the switching conditions depending on the adjusted mode of the controller and the level.

**Note:**

Keep in mind that the mode switch of VEGAWAVE 62 must be always set to "max.".

Mode on the controller	Level	Signal current - Sensor	Signal lamp - sensor	Signal lamp - controller
Mode A Overflow protection		approx. 8 mA	 Green	
Mode A Overflow protection		approx. 16 mA	 Red	
Mode B Dry run protection		approx. 16 mA	 Red	
Mode B Dry run protection		approx. 8 mA	 Green	

1) You can find suitable controllers in chapter "Technical data".

Mode on the controller	Level	Signal current - Sensor	Signal lamp - sensor	Signal lamp - controller
Fault message (mode A/B)	any	< 2.3 mA	 flashes red	

6.4 Proof test (SIL)

General information

The VEGAWAVE 62 is qualified for use in measuring chains of level SIL2 according to IEC 61508 (redundant, level SIL3).

SIL

The measuring system can be used for level detection of bulk solids and meets the special requirements of safety technology.

This is possible up to SIL2 in a single channel architecture (1oo1D), and up to SIL3 in a multiple channel, redundant architecture.

The following instrument combinations meet the requirements according to SIL:

VEGAWAVE 62 Ex with

- Oscillator WE60Z
- Controller VEGATOR 636 Ex or SPLC (safety-oriented PLC)

Implementation - Function test

The following options are available for carrying out the proof test:

1. Filling of the vessel up to the switching point
2. Dismounting of the sensor and immersion in the original medium
3. Short interruption of the supply line to the sensor
4. Pushing the test key on the controller

1 Filling the vessel up to the switching point

If this does not cause any problems, you can fill the vessel up to the switching point and monitor the correct sensor reaction.

2 Dismounting of the sensor and immersion in the original medium

You can dismount the sensor for test purposes and check its proper functioning by immersing it in the original product.

3 Short interruption of the supply line to the sensor

The recurring proof test according to IEC 61508 can be carried out through a short interruption (> 2 seconds) of the supply line to the sensor. This starts a test sequence.

The correctness of the subsequent switching conditions on the indications of the SPLC must be monitored. The sensor must neither be dismounted nor triggered by filling the vessel.

You can carry out the function test with the output current values also directly via a safety PLC or a process control system.

4 Pushing the test key on the controller

A test key is lowered in the front plate of the controller. Push the test key for > 2 seconds with a suitable object. Hence a test is started. Hence the correctness of the subsequent switching conditions must be monitored via the two LEDs on the controller as well as the connected facilities. The sensor must neither be dismantled, nor controlled by filling the vessel.

Test without filling or dismantling the sensor (3, 4)

This test is valid if you cannot change the vessel filling or cannot dismantle the sensor.

The proof test according to IEC 61508 can be carried out by pushing the test key on a respective controller or briefly (> 2 seconds) interrupting the supply line to the sensor.

The correctness of the subsequent switching conditions must be monitored via the two LEDs on the controller as well as the connected devices. The sensor must neither be dismantled nor triggered by filling the vessel.

This applies for VEGAWAVE 62 with two-wire electronics module WE60Z.

You can carry out the function test with the output current values also directly via a safety PLC or a process control system.

A function test can be carried out with measurement setups in conjunction with the two-wire electronics module WE60Z EX.

If you are using a controller of type VEGATOR for this purpose, you can also carry out the test also with the integrated test key. The test key is recessed in the front plate of the controller. Push the test key for > 2 seconds with a suitable object (screwdriver, pen, etc.).

When the VEGAWAVE 62 is connected to a processing system or an SPLC, you have to interrupt the connection cable to the sensor for > 2 seconds. The switching delay must be set to 0.5 s.

After releasing the test key or interrupting the connection cable to the sensor, the complete measuring system can be checked on correct function. The following operating conditions are simulated during the test:

- Fault message
- Empty signal
- Full signal

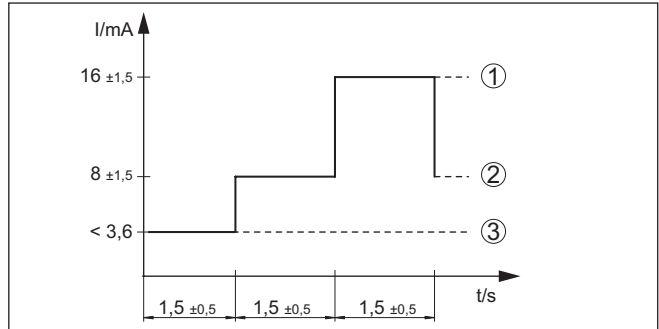

Fig. 13: Flow chart of the function test (mode "max.")

- 1 Full signal
- 2 Empty signal
- 3 Fault message

Check if all three switching conditions occur in the correct sequence and the stated time period. If this is not the case, there is a fault in the measuring system (see also the operating instructions manual of the controller). Keep in mind that connected instruments are activated during the function test. By doing this, you can check the correct function of the measuring system.



Note:

Keep in mind that the starting time t_A of the voltage supply can extend the time up to the first switching (e.g. VEGATOR 636: +1 s)

Test procedure

After releasing the button or after a brief line break.

	Sensor current - Sensor	Level relay A - overfill protection	Signal lamp A - Overfill protection	Level relay B - dry run protection	Signal lamp B - Dry run protection	Fail safe relay	Control lamp
1. Fault message approx. 1.5 ±0.5 s + t_A ²⁾	< 3.6 mA	currentless	○	currentless	○	currentless	☀
2. Empty signal 1.5 s ±0.5 s	8 mA ±1.5 mA	energized	☀	currentless	○	energized	○
3. Full signal 1.5 s ±0.5 s	16 mA ±1.5 mA	currentless	○	energized	☀	energized	○

2) Starting time of the voltage supply

	Sensor current - Sensor	Level relay A - overflow protection	Signal lamp A - Overflow protection	Level relay B - dry run protection	Signal lamp B - Dry run protection	Fail safe relay	Control lamp
4. Return to current operating condition	-	-	-	-	-	-	

Test assessment (SPLC)**Test passed**

Status	Current value	Time
False signal	< 3.6 mA	1.5 s ±0.5 s
Uncovered	8 mA ±1.5 mA	1.5 s ±0.5 s
Covered	16 mA ±1.5 mA	1.5 s ±0.5 s

7 Maintenance and fault rectification

7.1 Maintenance

Maintenance

If the device is used properly, no special maintenance is required in normal operation.

Cleaning

The cleaning helps that the type label and markings on the instrument are visible.

Take note of the following:

- Use only cleaning agents which do not corrode the housings, type label and seals
- Use only cleaning methods corresponding to the housing protection rating

7.2 Rectify faults

Reaction when malfunction occurs

The operator of the system is responsible for taking suitable measures to rectify faults.

Causes of malfunction

The device offers maximum reliability. Nevertheless, faults can occur during operation. These may be caused by the following, e.g.:

- Sensor
- Process
- Voltage supply
- Signal processing

Fault rectification

The first measure to take is to check the output signal. In many cases, the causes can be determined this way and the faults quickly rectified.

24 hour service hotline

Should these measures not be successful, please call in urgent cases the VEGA service hotline under the phone no. **+49 1805 858550**.

The hotline is manned 7 days a week round-the-clock. Since we offer this service worldwide, the support is only available in the English language. The service is free, only standard call charges are incurred.

Checking the switching signal

Error	Cause	Rectification
VEGAWAVE 62 signals "covered" without being submerged (overflow protection) VEGAWAVE 62 signals "uncovered" when being submerged (dry run protection)	Operating voltage too low	Check operating voltage
	Electronics defective	Press the mode switch. If the instrument then changes the mode, the vibrating element may be covered with buildup or mechanically damaged. Should the switching function in the correct mode still be faulty, return the instrument for repair.
		Press the mode switch. If the instrument then does not change the mode, the electronics module may be defective. Exchange the electronics module.
	Unfavourable installation location	Mount the instrument at a location in the vessel where no dead zones or mounds can form.
	Buildup on the vibrating element	Check the vibrating element and the sensor for buildup and remove the buildup if there is any.
	Wrong mode selected	Set the mode switch on VEGAWAVE 62 to "max". Set the correct mode on the controller (A: overflow protection; B: dry run protection).
Signal lamp flashes red	Error on the vibrating element	Check if the vibrating element is damaged or extremely corroded.
	Interference on the electronics module	Exchanging the electronics module
	Instrument defective	Exchange the instrument or send it in for repair

Reaction after fault rectification

Depending on the reason for the fault and the measures taken, the steps described in chapter "Setup" must be carried out again or must be checked for plausibility and completeness.

7.3 Exchanging the electronics module

In general, all electronics modules of series WE60 can be interchanged. If you want to use an electronics module with a different signal output, you can download the corresponding operating instructions manual from our homepage under Downloads.



With Ex-d instruments, the housing cover may only be opened if there is no explosive atmosphere present.

Proceed as follows:

1. Switch off voltage supply
2. Unscrew the housing lid
3. Lift the opening levers of the terminals with a screwdriver
4. Pull the connection cables out of the terminals
5. Loosen the two screws with a screw driver (Torx size T10 or slot 4)

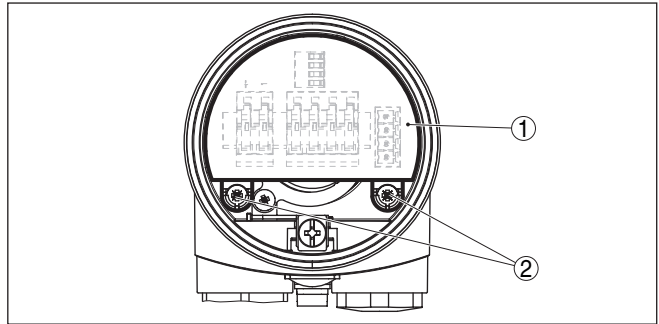

Fig. 14: Loosen the holding screws

- 1 Electronics module
- 2 Screws (2 pcs.)

6. Pull out the old electronics module
7. Compare the new electronics module with the old one. The type label of the electronics module must correspond to that of the old electronics module. This applies particularly to instruments used in hazardous areas.
8. Compare the settings of the two electronics modules. Set the adjustment elements of the new electronics module to the same setting of the old one.



Information:

Make sure that the housing is not rotated during the electronics exchange. Otherwise the plug may be in a different position later.

9. Insert the electronics module carefully. Make sure that the plug is in the correct position.
 10. Screw in and tighten the two holding screws with a screwdriver (Torx size T10 or Phillips 4)
 11. Insert the wire ends into the open terminals according to the wiring plan
 12. Press down the opening levers of the terminals, you will hear the terminal spring closing
 13. Check the hold of the wires in the terminals by lightly pulling on them
 14. Check cable gland on tightness. The seal ring must completely encircle the cable.
 15. Screw the housing lid back on
- The electronics exchange is now finished.

7.4 How to proceed if a repair is necessary

You can find an instrument return form as well as detailed information about the procedure in the download area of our homepage. By doing this you help us carry out the repair quickly and without having to call back for needed information.

In case of repair, proceed as follows:

- Print and fill out one form per instrument
- Clean the instrument and pack it damage-proof
- Attach the completed form and, if need be, also a safety data sheet outside on the packaging
- Ask the agency serving you to get the address for the return shipment. You can find the agency on our homepage.

8 Dismount

8.1 Dismounting steps

**Warning:**

Before dismantling, be aware of dangerous process conditions such as e.g. pressure in the vessel, high temperatures, corrosive or toxic products etc.

Take note of chapters "*Mounting*" and "*Connecting to voltage supply*" and carry out the listed steps in reverse order.



With Ex instruments, the housing cover may only be opened if there is no explosive atmosphere present.

8.2 Disposal



Pass the instrument on to a specialised recycling company and do not use the municipal collecting points.

Remove any batteries in advance, if they can be removed from the device, and dispose of them separately.

If personal data is stored on the old device to be disposed of, delete it before disposal.

If you have no way to dispose of the old instrument properly, please contact us concerning return and disposal.

9 Supplement

9.1 Technical data

Note for approved instruments

The technical data in the respective safety instructions which are included in delivery are valid for approved instruments (e.g. with Ex approval). These data can differ from the data listed herein, for example regarding the process conditions or the voltage supply.

All approval documents can be downloaded from our homepage.

General data

Material 316L corresponds to 1.4404 or 1.4435

Materials, wetted parts

– Process fitting - thread	316L
– Process fitting - flange	316L
– Process seal	Klingersil C-4400
– Seal (vibrating element)	CR, CSM
– Tuning fork	316L
– Suspension cable (-20 ... +80 °C/ 4 ... +176 °F)	PUR
– Suspension cable (-40 ... +150 °C/ 40 ... +302 °F) optionally	FEP

Materials, non-wetted parts

– Plastic housing	Plastic PBT (Polyester)
– Aluminium die-cast housing	Aluminium die-casting AlSi10Mg, powder-coated (Basis: Polyester)
– Stainless steel housing (precision casting)	316L
– Stainless steel housing (electropolished)	316L
– Seal between housing and housing lid	Silicone
– Light guide in housing cover (plastic)	PMMA (Makrolon)
– Ground terminal	316L
– Cable gland	PA, stainless steel, brass
– Sealing, cable gland	NBR
– Blind plug, cable gland	PA

Process fittings

– Pipe thread, cylindrical (DIN 3852-A)	G1½
– Pipe thread, conical (ASME B1.20.1)	1½ NPT

Weight approx.

– Instrument weight (depending on process fitting)	0.8 ... 4 kg (0.18 ... 8.82 lbs)
– Suspension cable (-20 ... +80 °C/ 4 ... +176 °F)	165 g/m (1.77 oz/ft)

- Suspension cable (-40 ... +150 °C/-40 ... +302 °F) optionally	200 g/m (2.15 oz/ft)
Max. permissible tensile load	3000 N (675 lbs)
Sensor length (L)	
- PUR Suspension cable (-20 ... +80 °C/-4 ... +176 °F)	0.48 ... 80 m (1.575 ... 262.47 ft)
- FEP Suspension cable (-40 ... +150 °C/-40 ... +302 °F)	0.6 ... 80 m (1.969 ... 262.47 ft)
Torque for NPT cable glands and Conduit tubes	
- Plastic housing	max. 10 Nm (7.376 lbf ft)
- Aluminium/Stainless steel housing	max. 50 Nm (36.88 lbf ft)

Output variable

Output	Two-wire output
Suitable signal conditioning instruments	VEGATOR 121, 122, 636 Ex
Output signal	
- Mode min.	Vibrating element uncovered: 16 mA ±1 mA, vibrating element covered: 8 mA ±1 mA
- Mode max.	Vibrating element uncovered: 8 mA ±1 mA, vibrating element covered: 16 mA ±1 mA
- Fault message	< 2.3 mA
Modes (switchable)	min./max.
Switching delay	
- When immersed	0.5 s
- When laid bare	1 s

Ambient conditions

Ambient temperature on the housing	-40 ... +80 °C (-40 ... +176 °F)
Storage and transport temperature	-40 ... +80 °C (-40 ... +176 °F)

Process conditions

Measured variable	Limit level of solids
Process pressure mit PUR-suspension cable	-1 ... 3 bar/-100 ... 300 kPa (-14.5 ... 43 psig)
Process pressure with FEP-suspension cable	-1 ... 6 bar/-100 ... 600 kPa (-14.5 ... 87 psig)
Process temperature with PUR suspension cable	-20 ... +80 °C (-4 ... +176 °F)
Process temperature with FEP suspension cable	-40 ... +150 °C (-40 ... +302 °F)
Product density	
- Standard sensitivity	> 0.02 g/cm ³ (0.0007 lbs/in ³)
- High sensitivity	> 0.008 g/cm ³ (0.0003 lbs/in ³)
Granular size	max. 10 mm (0.4 in)

Electromechanical data - version IP66/IP67 and IP66/IP68 (0.2 bar)

Options of the cable entry

- Cable entry M20 x 1.5; ½ NPT
- Cable gland M20 x 1.5; ½ NPT
- Blind plug M20 x 1.5; ½ NPT
- Closing cap ½ NPT

Wire cross-section (spring-loaded terminals)

- Massive wire, stranded wire 0.2 ... 2.5 mm² (AWG 24 ... 14)
- Stranded wire with end sleeve 0.2 ... 1.5 mm² (AWG 24 ... 16)

Electromechanical data - version IP66/IP68 (1 bar)

Options of the cable entry

- Cable entry M20 x 1.5; ½ NPT
- Cable gland M20 x 1.5; ½ NPT
- Blind plug M20 x 1.5; ½ NPT
- Closing cap ½ NPT

Connection cable

- Wire cross-section > 0.5 mm² (AWG 20)
- Wire resistance < 0.036 Ω/m (0.011 Ω/ft)
- Tensile strength < 1200 N (270 lbf)
- Standard length 5 m (16.4 ft)
- Max. length 1000 m (3280 ft)
- Min. bending radius 25 mm (0.984 in) with 25 °C (77 °F)
- Diameter approx. 8 mm (0.315 in)
- Colour - standard PE Black
- Colour - standard PUR Blue
- Colour - Ex-version Blue

Adjustment elements

Mode switch

- Min. Min. detection or dry run protection
- Max. Max. detection or overflow protection

Voltage supply

Operating voltage 10 ... 36 V DC (via the controller)

Electrical protective measures

Protection rating A suitable cable is required for maintaining the protection rating.

Housing material	Protection acc. to IEC 60529	Protection acc. to NEMA
Plastic	IP66/IP67	Type 4X

Housing in protection IP66/IP68 (1 bar)

Fig. 16: Housing versions with protection rating IP66/IP68 (1 bar)

- 1 Stainless steel single chamber (precision casting)
- 2 Aluminium - single chamber

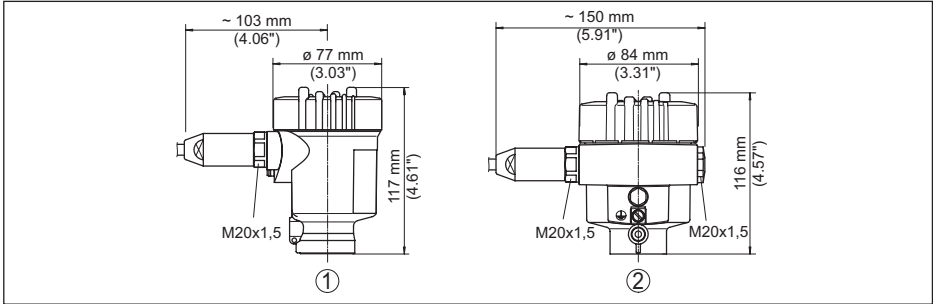
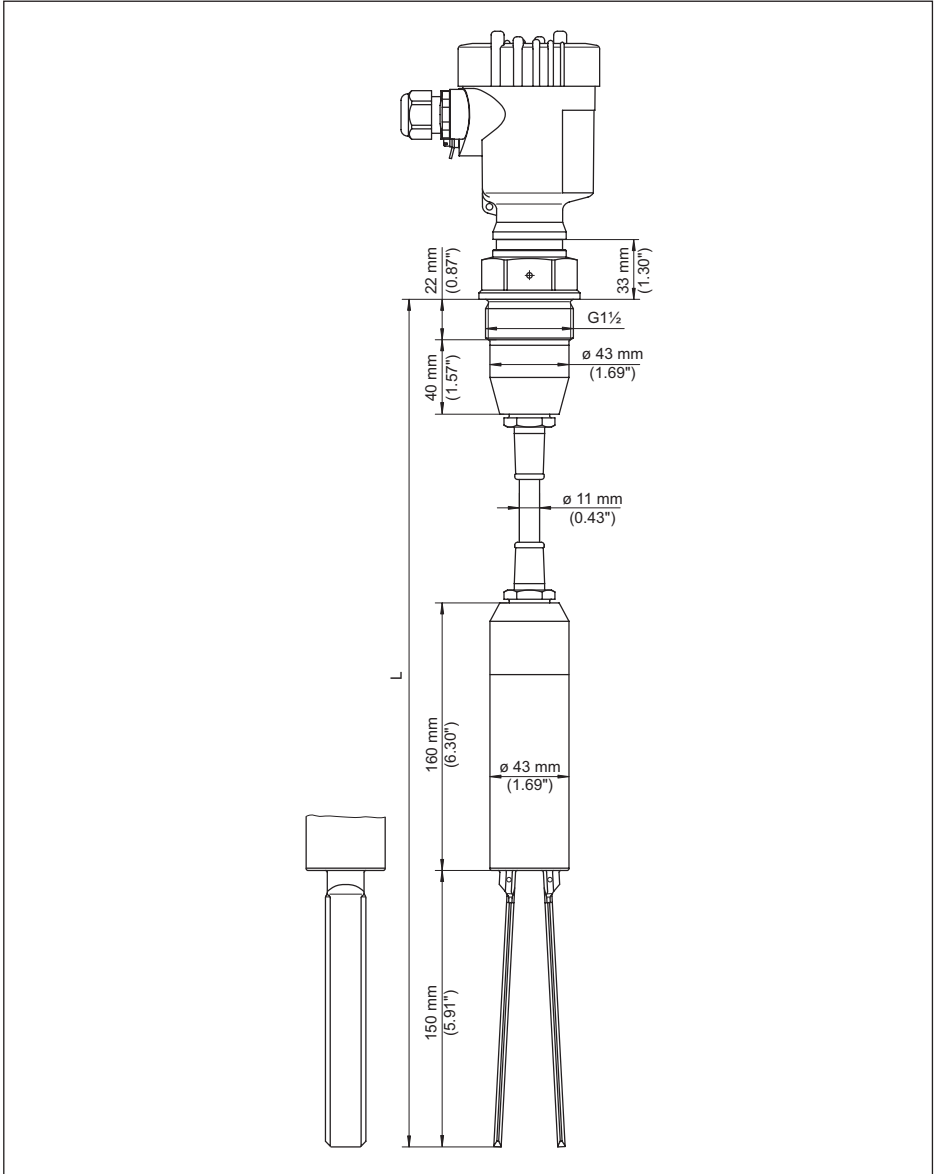

Fig. 17: VEGAWAVE 62 with PUR suspension cable, threaded version G1½ (DIN ISO 228/1)

L Sensor length, see chapter "Technical data"

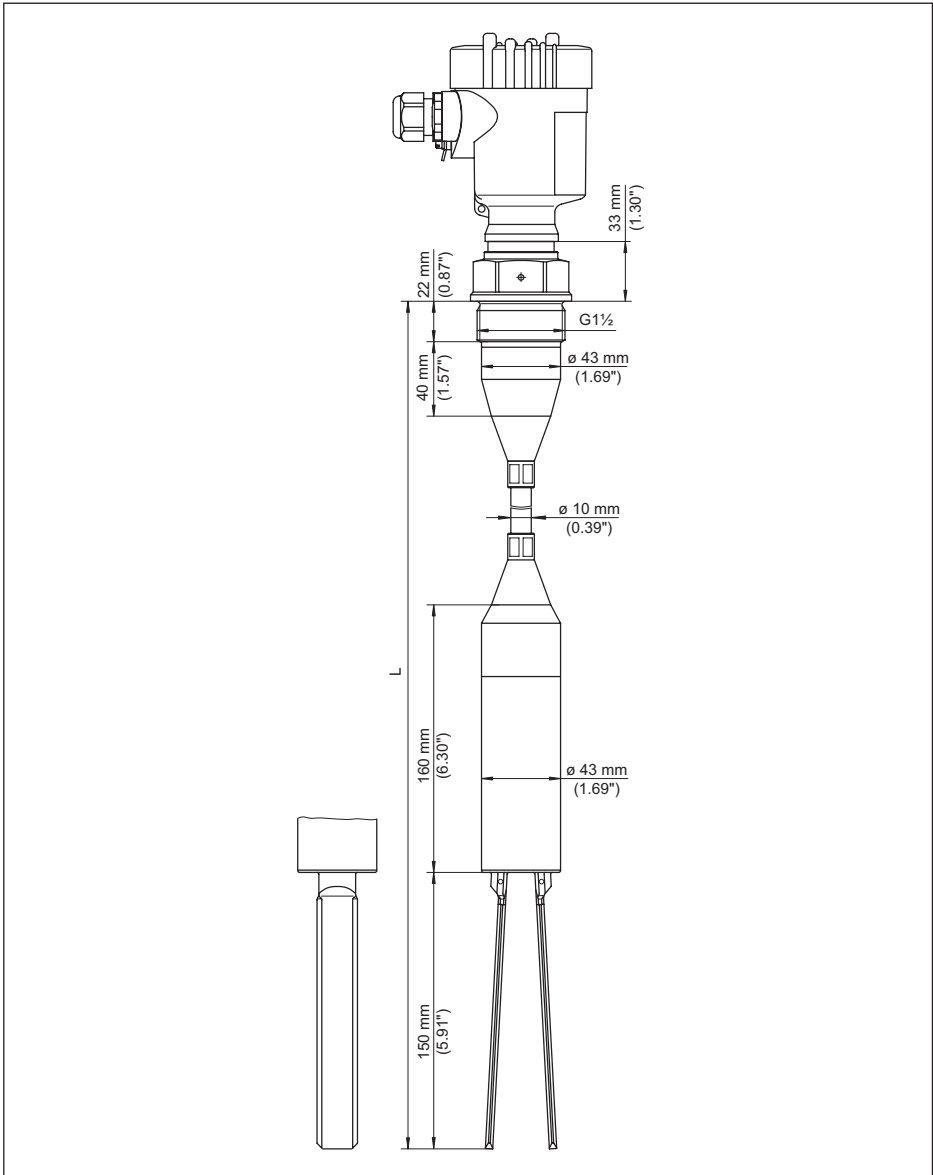

Fig. 18: VEGAWAVE 62 with FEP suspension cable, threaded version G1½ (DIN ISO 228/1)

L Sensor length, see chapter "Technical data"

9.3 Industrial property rights

VEGA product lines are global protected by industrial property rights. Further information see www.vega.com.

VEGA Produktfamilien sind weltweit geschützt durch gewerbliche Schutzrechte.

Nähere Informationen unter www.vega.com.

Les lignes de produits VEGA sont globalement protégées par des droits de propriété intellectuelle. Pour plus d'informations, on pourra se référer au site www.vega.com.

VEGA lineas de productos están protegidas por los derechos en el campo de la propiedad industrial. Para mayor información revise la pagina web www.vega.com.

Линии продукции фирмы ВЕГА защищаются по всему миру правами на интеллектуальную собственность. Дальнейшую информацию смотрите на сайте www.vega.com.

VEGA系列产品在全球享有知识产权保护。

进一步信息请参见网站 < www.vega.com。

9.4 Trademark

All the brands as well as trade and company names used are property of their lawful proprietor/originator.

A large grid of graph paper for taking notes, consisting of 20 columns and 30 rows of small squares.



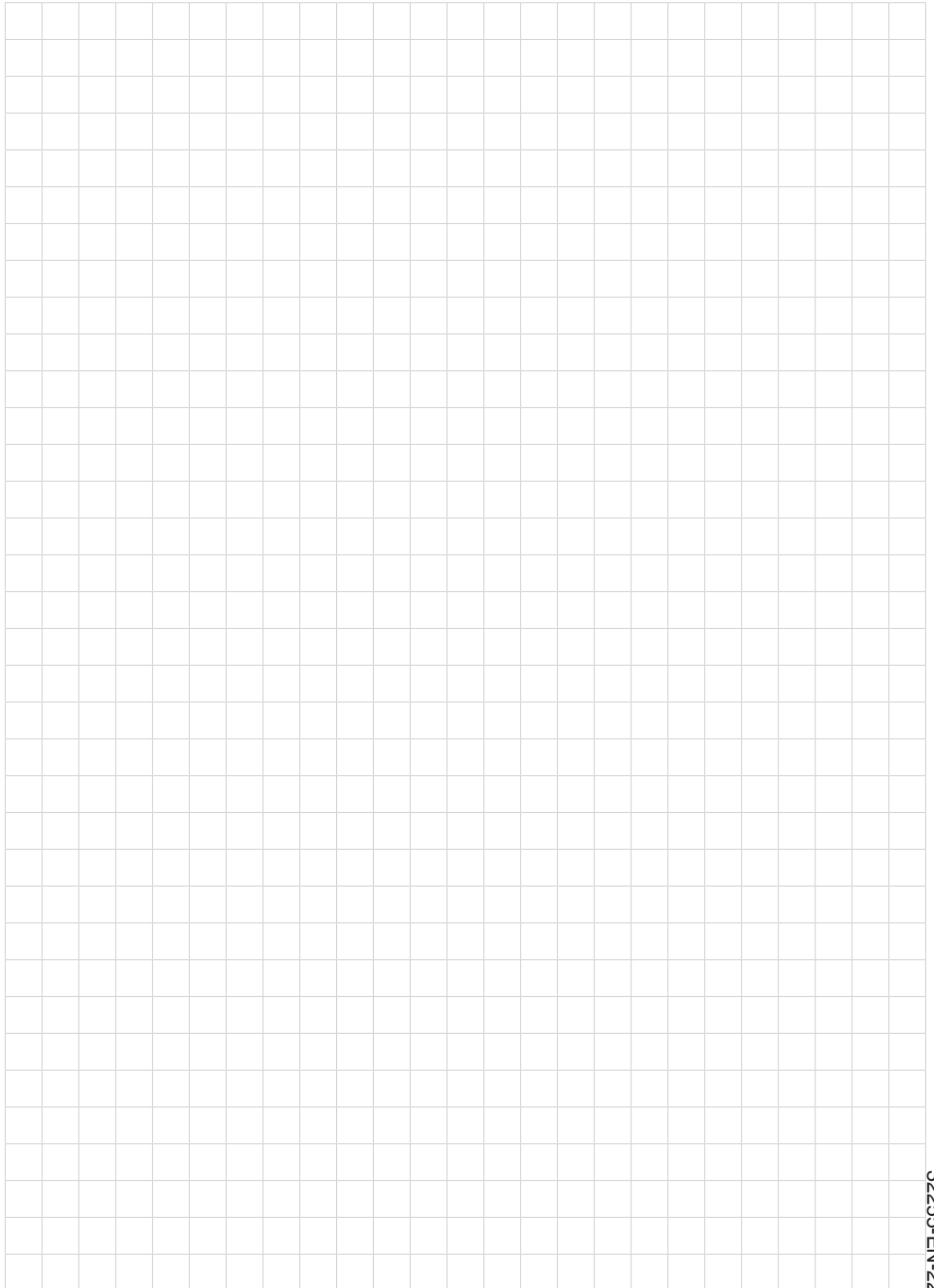



Printing date:

VEGA

All statements concerning scope of delivery, application, practical use and operating conditions of the sensors and processing systems correspond to the information available at the time of printing.

Subject to change without prior notice

© VEGA Grieshaber KG, Schiltach/Germany 2022



32255-EN-221012

VEGA Grieshaber KG
Am Hohenstein 113
77761 Schiltach
Germany

Phone +49 7836 50-0
E-mail: info.de@vega.com
www.vega.com