

Operating Instructions

Capacitive high temperature probe for level detection

VEGACAP 67

Two-wire



Document ID: 31317



VEGA

Contents

1	About this document	4
1.1	Function	4
1.2	Target group	4
1.3	Symbols used	4
2	For your safety	5
2.1	Authorised personnel	5
2.2	Appropriate use	5
2.3	Warning about incorrect use	5
2.4	General safety instructions	5
2.5	Conformity	6
2.6	Installation and operation in the USA and Canada	6
2.7	Safety instructions for Ex areas	6
2.8	Environmental instructions	6
3	Product description	7
3.1	Configuration	7
3.2	Principle of operation	10
3.3	Adjustment	10
3.4	Packaging, transport and storage	10
3.5	Accessories	11
4	Mounting	12
4.1	General instructions	12
4.2	Mounting instructions	14
5	Connecting to power supply	17
5.1	Preparing the connection	17
5.2	Connection procedure	17
5.3	Wiring plan - single chamber housing	18
5.4	Wiring plan - version IP66/IP68, 1 bar	20
5.5	Warm-up reaction	20
6	Setup	21
6.1	General information	21
6.2	Adjustment elements	21
7	Diagnostics and servicing	23
7.1	Maintenance	23
7.2	Rectify faults	23
7.3	Exchange of the electronics module	24
7.4	Shortening of the probe	26
7.5	How to proceed if a repair is necessary	27
8	Dismount	28
8.1	Dismounting steps	28
8.2	Disposal	28
9	Supplement	29
9.1	Technical data	29
9.2	Dimensions	32
9.3	Industrial property rights	35
9.4	Trademark	35

1 About this document

1.1 Function

This instruction provides all the information you need for mounting, connection and setup as well as important instructions for maintenance, fault rectification, the exchange of parts and the safety of the user. Please read this information before putting the instrument into operation and keep this manual accessible in the immediate vicinity of the device.

1.2 Target group

This operating instructions manual is directed to trained personnel. The contents of this manual must be made available to the qualified personnel and implemented.

1.3 Symbols used



Document ID

This symbol on the front page of this instruction refers to the Document ID. By entering the Document ID on www.vega.com you will reach the document download.



Information, note, tip: This symbol indicates helpful additional information and tips for successful work.



Note: This symbol indicates notes to prevent failures, malfunctions, damage to devices or plants.



Caution: Non-observance of the information marked with this symbol may result in personal injury.



Warning: Non-observance of the information marked with this symbol may result in serious or fatal personal injury.



Danger: Non-observance of the information marked with this symbol results in serious or fatal personal injury.



Ex applications

This symbol indicates special instructions for Ex applications.



List

The dot set in front indicates a list with no implied sequence.



Sequence of actions

Numbers set in front indicate successive steps in a procedure.



Disposal

This symbol indicates special instructions for disposal.

2 For your safety

2.1 Authorised personnel

All operations described in this documentation must be carried out only by trained, qualified personnel authorised by the plant operator.

During work on and with the device, the required personal protective equipment must always be worn.

2.2 Appropriate use

The VEGACAP 67 is a sensor for point level detection.

You can find detailed information about the area of application in chapter " *Product description*".

Operational reliability is ensured only if the instrument is properly used according to the specifications in the operating instructions manual as well as possible supplementary instructions.

For safety and warranty reasons, any invasive work on the device beyond that described in the operating instructions manual may be carried out only by personnel authorised by the manufacturer. Arbitrary conversions or modifications are explicitly forbidden.

2.3 Warning about incorrect use

Inappropriate or incorrect use of this product can give rise to application-specific hazards, e.g. vessel overflow through incorrect mounting or adjustment. Damage to property and persons or environmental contamination can result. Also, the protective characteristics of the instrument can be impaired.

2.4 General safety instructions

This is a state-of-the-art instrument complying with all prevailing regulations and directives. The instrument must only be operated in a technically flawless and reliable condition. The operator is responsible for the trouble-free operation of the instrument. When measuring aggressive or corrosive media that can cause a dangerous situation if the instrument malfunctions, the operator has to implement suitable measures to make sure the instrument is functioning properly.

The safety instructions in this operating instructions manual, the national installation standards as well as the valid safety regulations and accident prevention rules must be observed by the user.

For safety and warranty reasons, any invasive work on the device beyond that described in the operating instructions manual may be carried out only by personnel authorised by the manufacturer. Arbitrary conversions or modifications are explicitly forbidden. For safety reasons, only the accessory specified by the manufacturer must be used.

To avoid any danger, the safety approval markings and safety tips on the device must also be observed.

2.5 Conformity

The device complies with the legal requirements of the applicable country-specific directives or technical regulations. We confirm conformity with the corresponding labelling.

The corresponding conformity declarations can be found on our homepage.

2.6 Installation and operation in the USA and Canada

This information is only valid for USA and Canada. Hence the following text is only available in the English language.

Installations in the US shall comply with the relevant requirements of the National Electrical Code (NEC - NFPA 70) (USA).

Installations in Canada shall comply with the relevant requirements of the Canadian Electrical Code (CEC Par I) (Canada).

2.7 Safety instructions for Ex areas

For applications in explosion-proof areas (Ex), only devices with corresponding Ex approval may be used. Observe the Ex-specific safety instructions. These are an integral part of the operating instructions and are enclosed with every device with Ex approval.

2.8 Environmental instructions

Protection of the environment is one of our most important duties. That is why we have introduced an environment management system with the goal of continuously improving company environmental protection. The environment management system is certified according to DIN EN ISO 14001.

Please help us fulfil this obligation by observing the environmental instructions in this manual:

- Chapter "*Packaging, transport and storage*"
- Chapter "*Disposal*"

3 Product description

3.1 Configuration

Scope of delivery

The scope of delivery encompasses:

- VEGACAP 67 point level switch

The further scope of delivery encompasses:

- Documentation
 - Operating instructions VEGACAP 67
 - Safety Manual (SIL)
 - Instructions for optional instrument features
 - Ex-specific "*Safety instructions*" (with Ex versions)
 - If necessary, further certificates



Information:

Optional instrument features are also described in this operating instructions manual. The respective scope of delivery results from the order specification.

Scope of this operating instructions

This operating instructions manual applies to the following instrument versions:

- Hardware from 1.0.0
- Software from 1.3.0
- Only for instrument versions without SIL qualification

Constituent parts

The VEGACAP 67 consists of the components:

- Process fitting with probe
- Housing with electronics
- Housing cover, optionally available with display and adjustment module

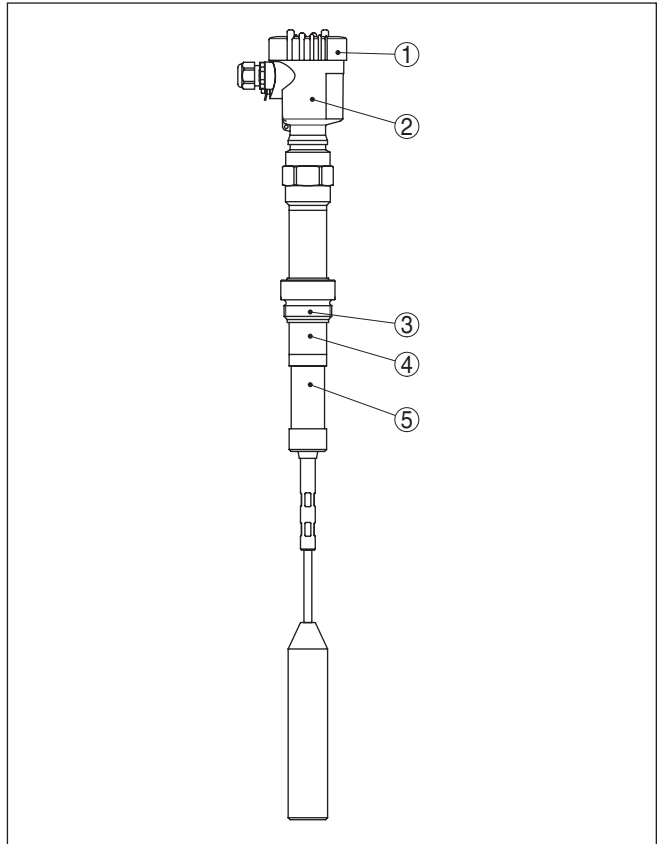

Fig. 1: VEGACAP 67 with plastic housing

- 1 Housing lid
- 2 Housing with electronics
- 3 Process fitting
- 4 Supporting tube
- 5 Ceramic insulator

Type label

The type label contains the most important data for identification and use of the instrument:

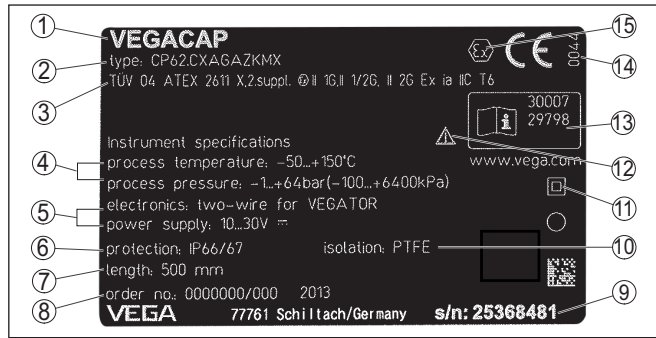

Fig. 2: Layout of the type label (example)

- 1 Instrument type
- 2 Product code
- 3 Approvals
- 4 Process and ambient temperature, process pressure
- 5 Power supply and signal output, electronics
- 6 Protection rating
- 7 Probe length
- 8 Order number
- 9 Serial number of the instrument
- 10 Material wetted parts
- 11 Symbol of the device protection class
- 12 Reminder to observe the instrument documentation
- 13 ID numbers, instrument documentation
- 14 Notified authority for CE marking
- 15 Approval directives

With the serial number, you can access the delivery data of the instrument via "www.vega.com", "Search". You can find the serial number on the inside of the instrument as well as on the type label on the outside.

Serial number - Instrument search

The type label contains the serial number of the instrument. With it you can find the following instrument data on our homepage:

- Product code (HTML)
- Delivery date (HTML)
- Order-specific instrument features (HTML)
- Operating instructions and quick setup guide at the time of shipment (PDF)
- Test certificate (PDF) - optional

Move to "www.vega.com" and enter in the search field the serial number of your instrument.

Alternatively, you can access the data via your smartphone:

- Download the VEGA Tools app from the "Apple App Store" or the "Google Play Store"
- Scan the QR-code on the type label of the device or
- Enter the serial number manually in the app

3.2 Principle of operation

Application area

The VEGACAP 67 is a point level sensor for bulk solids. The probe is designed for high temperature applications.

Functional principle

Probe, measured product and vessel wall form an electrical capacitor. The capacitance is influenced by three main factors.

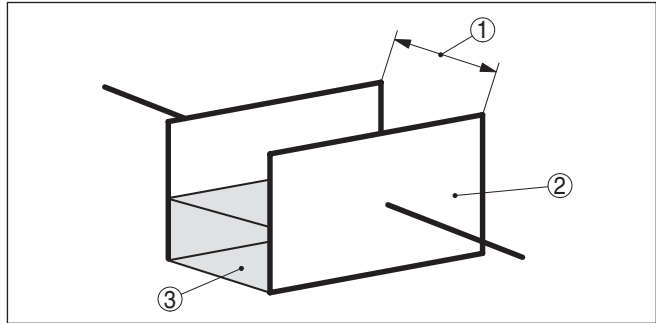

Fig. 3: Functional principle - Plate capacitor

- 1 Distance between the electrode surfaces
- 2 Size of the electrode surfaces
- 3 Type of dielectric between the electrodes

The probe and the vessel wall are the capacitor plates. The measured product is the dielectric. Due to the higher dielectric constant of the product compared to air, the capacitance increases as the probe is gradually covered.

The capacitance change is converted by the electronics module into a switching command.

Voltage supply

Depending on your requirements, VEGACAP 67 with two-wire electronics can be connected to different controllers. Compatible controllers are listed in chapter "Technical data".

The data for power supply are specified in chapter "Technical data".

3.3 Adjustment

The probe can be adapted to the dielectric constant of the product directly on the electronics module.

A switching command can be triggered when the probe is covered or laid bare.

On the electronics module you will find the following display and adjustment elements:

- Control lamp for indication of the device status.

3.4 Packaging, transport and storage

Your instrument was protected by packaging during transport. Its capacity to handle normal loads during transport is assured by a test based on ISO 4180.

Packaging

The packaging of standard instruments consists of environment-friendly, recyclable cardboard. For special versions, PE foam or PE foil is also used. Dispose of the packaging material via specialised recycling companies.

Transport

Transport must be carried out in due consideration of the notes on the transport packaging. Nonobservance of these instructions can cause damage to the device.

Transport inspection

The delivery must be checked for completeness and possible transit damage immediately at receipt. Ascertained transit damage or concealed defects must be appropriately dealt with.

Storage

Up to the time of installation, the packages must be left closed and stored according to the orientation and storage markings on the outside.

Unless otherwise indicated, the packages must be stored only under the following conditions:

- Not in the open
- Dry and dust free
- Not exposed to corrosive media
- Protected against solar radiation
- Avoiding mechanical shock and vibration

Storage and transport temperature

- Storage and transport temperature see chapter " *Supplement - Technical data - Ambient conditions* "
- Relative moisture 20 ... 85 %

Lifting and carrying

With instrument weights of more than 18 kg (39.68 lbs) suitable and approved equipment must be used for lifting and carrying.

3.5 Accessories

The instructions for the listed accessories can be found in the download area on our homepage.

Protective cover

The protective cover protects the sensor housing against soiling and intense heat from solar radiation.

Flanges

Screwed flanges are available in different versions according to the following standards: DIN 2501, EN 1092-1, BS 10, ASME B 16.5, JIS B 2210-1984, GOST 12821-80.

4 Mounting

4.1 General instructions

Process conditions



Note:

For safety reasons, the instrument must only be operated within the permissible process conditions. You can find detailed information on the process conditions in chapter " *Technical data*" of the operating instructions or on the type label.

Hence make sure before mounting that all parts of the instrument exposed to the process are suitable for the existing process conditions.

These are mainly:

- Active measuring component
- Process fitting
- Process seal

Process conditions in particular are:

- Process pressure
- Process temperature
- Chemical properties of the medium
- Abrasion and mechanical influences

Switching point

In general, VEGACAP 67 must be mounted vertically. The instrument must be mounted in such a way that the probe is at the height of the requested switching point.

Welding work

Before beginning the welding work, remove the electronics module from the sensor. By doing this, you avoid damage to the electronics through inductive coupling.

Ground the probe before welding directly on the rod or cable.

Screwing in

Devices with threaded fitting are screwed into the process fitting with a suitable wrench via the hexagon.

See chapter " *Dimensions*" for wrench size.



Warning:

The housing or the electrical connection may not be used for screwing in! Depending on the device version, tightening can cause damage, e. g. to the rotation mechanism of the housing.

Handling

With threaded versions, the housing must not be used to screw in the instrument! Applying tightening forces on the housing can damage its internal parts.

Use the hexagon for screwing in.

Moisture

Use the recommended cables (see chapter " *Connecting to power supply*") and tighten the cable gland.

You can give your instrument additional protection against moisture penetration by leading the connection cable downward in front of the cable gland. Rain and condensation water can thus drain off. This

applies mainly to outdoor mounting as well as installation in areas where high humidity is expected (e.g. through cleaning processes) or on cooled or heated vessels.

To maintain the housing protection, make sure that the housing lid is closed during operation and locked, if necessary.

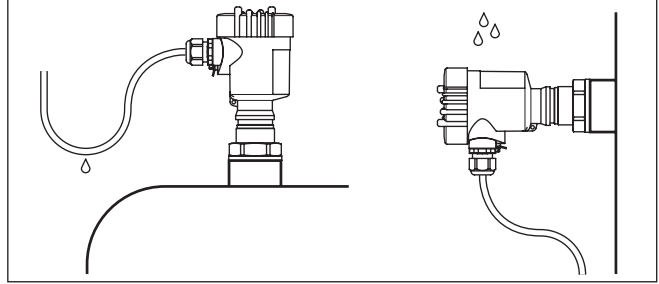

Fig. 4: Measures against moisture ingress

Pressure/Vacuum

The process fitting must be sealed if there is gauge or low pressure in the vessel. Before use, check if the sealing material is resistant against the measured product and the process temperature.

The max. permissible pressure is specified in chapter " *Technical data*" or on the type label of the sensor.

Vessel material

Metal vessel

Make sure that the mechanical connection of the probe to the vessel is electrically conductive to ensure sufficient grounding.

Use conductive seals, such as those made of copper or lead, etc. Insulating measures, such as covering the thread with Teflon tape, can interrupt the necessary electrical connection with metal vessels. For this reason, ground the probe on the vessel or use a conductive seal material.

Non-conductive vessels

In non-conductive vessels, e.g. plastic tanks, the second pole of the capacitor must be provided separately.

**Cable entries - NPT thread
Cable glands**

Metric threads

In the case of instrument housings with metric thread, the cable glands are screwed in at the factory. They are sealed with plastic plugs as transport protection.

You have to remove these plugs before electrical connection.

NPT thread

In the case of instrument housings with self-sealing NPT threads, it is not possible to have the cable entries screwed in at the factory. The free openings for the cable glands are therefore covered with red dust protection caps as transport protection.

Prior to setup you have to replace these protective caps with approved cable glands or close the openings with suitable blind plugs.

4.2 Mounting instructions

Agitators and fluidization Due to the effects of agitators, equipment vibration or similar, the level switch can be subjected to strong lateral forces. For this reason, do not use an overly long electrode for VEGACAP 67, but check if you can mount a short level switch on the side of the vessel in horizontal position.

Inflowing medium If the instrument is mounted in the filling stream, unwanted false measurement signals can be generated. For this reason, mount the instrument at a position in the vessel where no disturbances, e.g. from filling openings, agitators, etc., can occur.

This applies particularly to instrument versions with a longer probe.

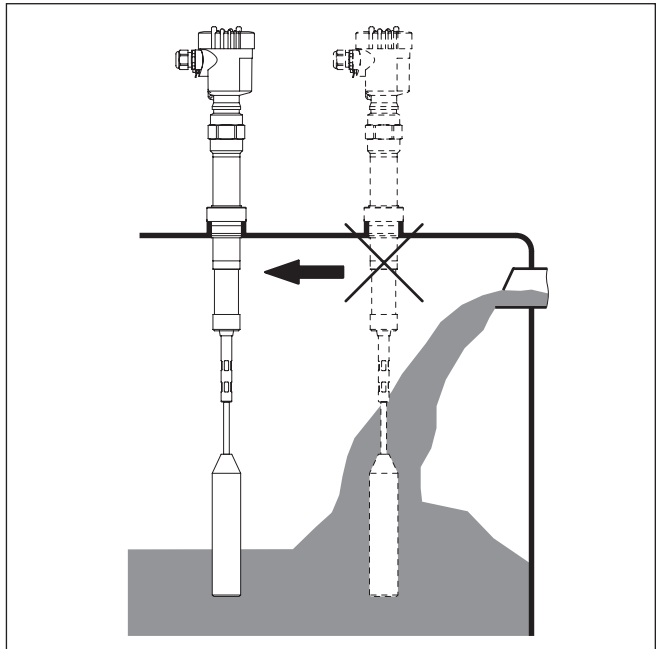

Fig. 5: Inflowing medium

Nozzle The probe should protrude into the vessel to avoid buildup. For that reason, avoid using mounting bosses for flanges and screwed fittings. This applies particularly to use with adhesive products.

Material cone In silos with bulk solids, material cones can form which change the switching point. Please keep this in mind when installing the sensor in the vessel. We recommend selecting an installation location where the probe detects the average value of the material cone.

The probe must be mounted in a way that takes the arrangement of the filling and emptying apertures into account.

To compensate measurement errors caused by the material cone in cylindrical vessels, the sensor must be mounted at a distance of $d/6$ from the vessel wall.

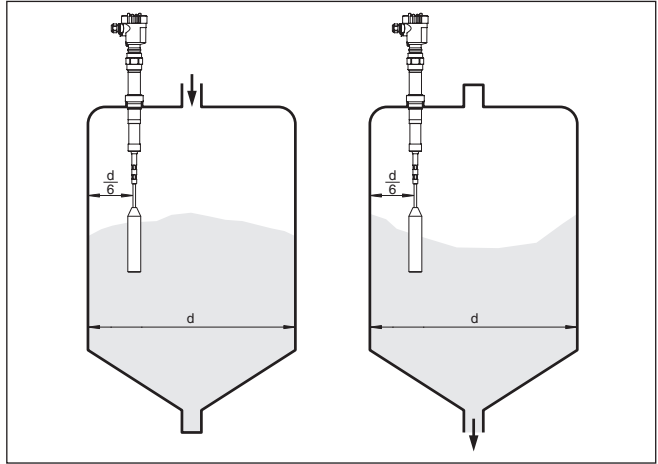

Fig. 6: Filling and emptying centred

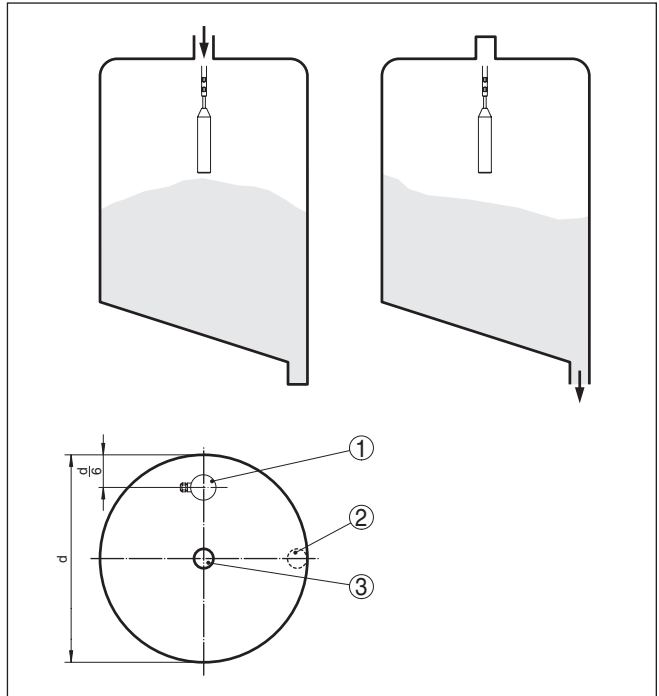

Fig. 7: Filling in the centre, emptying laterally

- 1 VEGACAP 67
- 2 Discharge opening
- 3 Filling opening

Tensile load

Make sure that the max. permissible tensile load of the suspension cable is not exceeded. The danger of this happening exists particularly with very heavy solids and large meas. lengths. The max. permissible load is stated in chapter " *Technical data*".

5 Connecting to power supply

5.1 Preparing the connection

Safety instructions

Always keep in mind the following safety instructions:

- Carry out electrical connection by trained, qualified personnel authorised by the plant operator



Warning:

Only connect or disconnect in de-energized state.

Voltage supply

Connect the operating voltage according to the following diagrams. Take note of the general installation regulations. As a rule, connect VEGACAP 67 to vessel ground (PA), or in case of plastic vessels, to the next ground potential. On the side of the instrument housing there is a ground terminal between the cable entries. This connection serves to drain off electrostatic charges. In Ex applications, the installation regulations for hazardous areas must be given priority.

The data for power supply are specified in chapter " *Technical data*".

Connection cable

The instrument is connected with standard two-wire cable without shielding. If electromagnetic interference is expected which is above the test values of EN 61326-1 for industrial areas, shielded cable should be used.

Make sure that the cable used has the required temperature resistance and fire safety for max. occurring ambient temperature

Use cable with round cross section for instruments with housing and cable gland. To ensure the seal effect of the cable gland (IP protection rating), find out which cable outer diameter the cable gland is suitable for.

Use a cable gland fitting the cable diameter.

Cover all housing openings conforming to standard according to EN 60079-1.

5.2 Connection procedure



With Ex instruments, the housing cover may only be opened if there is no explosive atmosphere present.

Proceed as follows:

1. Unscrew the housing lid
2. Loosen compression nut of the cable gland and remove blind plug
3. Remove approx. 10 cm (4 in) of the cable mantle, strip approx. 1 cm (0.4 in) of insulation from the ends of the individual wires
4. Insert the cable into the sensor through the cable entry
5. Lift the opening levers of the terminals with a screwdriver (see following illustration)

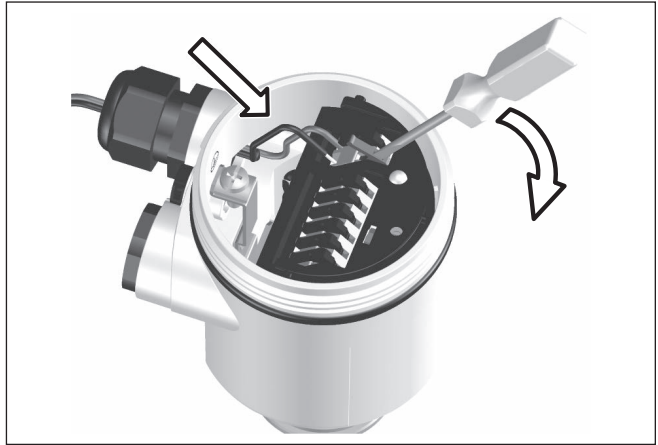

Fig. 8: Connection steps 5 and 6

6. Insert the wire ends into the open terminals according to the wiring plan
7. Press down the opening levers of the terminals, you will hear the terminal spring closing
8. Check the hold of the wires in the terminals by lightly pulling on them
9. Tighten the compression nut of the cable entry gland. The seal ring must completely encircle the cable
10. If necessary, carry out a fresh adjustment
11. Screw the housing lid back on

The electrical connection is finished.

5.3 Wiring plan - single chamber housing

Housing overview

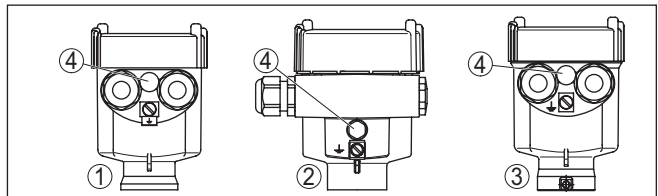

Fig. 9: Material versions - single chamber housing

- 1 Plastic (not with dust-Ex)
- 2 Aluminium
- 3 Stainless steel
- 4 Filter element for pressure compensation or blind plug with version IP66/ IP68, 1 bar

Electronics and connection compartment

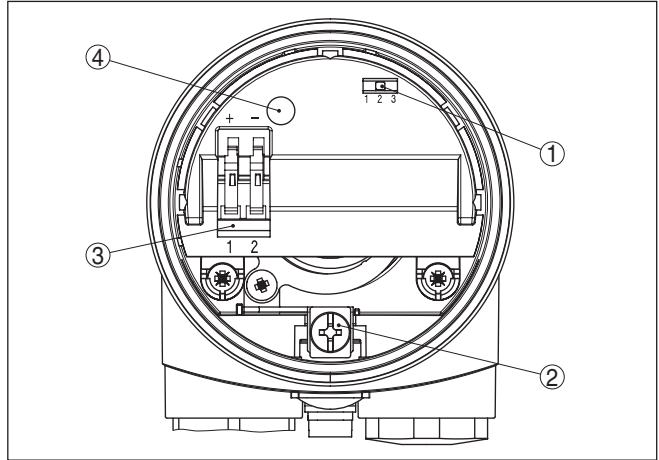

Fig. 10: Electronics and connection compartment

- 1 DIL switch for measuring range selection
- 2 Ground terminal
- 3 Connection terminals
- 4 Control lamp

Wiring plan

For connection to a controller. The sensor is powered by the connected controller. Further information is available in chapter " *Technical data*", " *Ex-technical data*" are available in the " *Safety information*".

The wiring example is applicable for all suitable controllers.

Take note of the operating instructions manual of the controller. Suitable controllers are listed in chapter " *Technical data*".

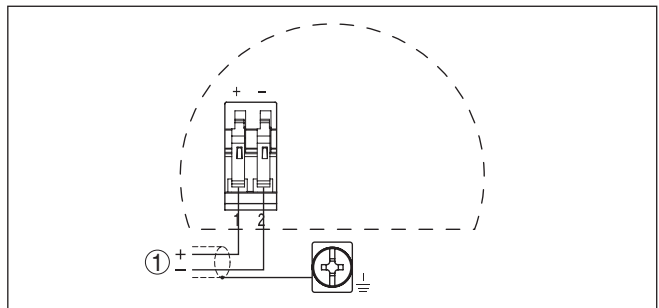

Fig. 11: Wiring plan

- 1 Voltage supply

Wire assignment, connection cable

5.4 Wiring plan - version IP66/IP68, 1 bar

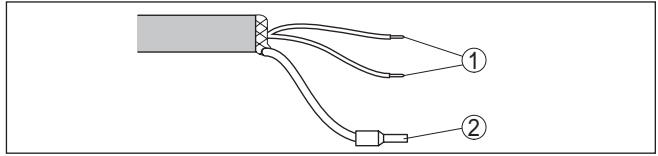

Fig. 12: Wire assignment, connection cable

- 1 Brown (+) and blue (-) to power supply or to the processing system
- 2 Shielding

5.5 Warm-up reaction

After connecting to voltage supply or after a voltage recurrence, the instrument passes a certain switch on routine.

By lowering the current value when switching on, the instrument can output briefly a fault signal.

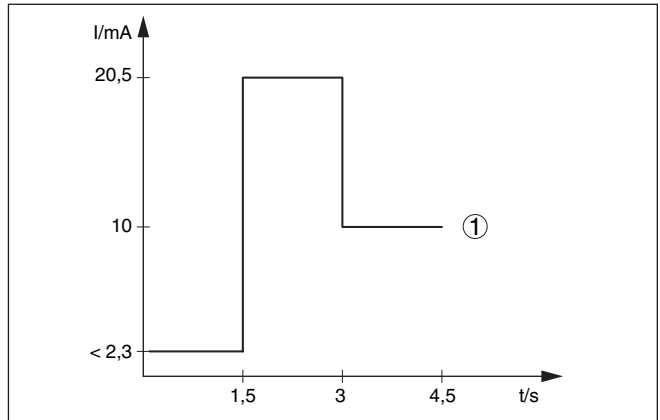

Fig. 13: Warm-up reaction

- 1 Measured value

6 Setup

6.1 General information

The figures in brackets refer to the following illustrations.

Function/Configuration On the electronics module you will find the following display and adjustment elements:

- DIL switch for measuring range selection
- Control lamp



Note:

As a rule, always set the mode with the mode switch of the signal conditioning instrument before starting setup VEGACAP 67. The switching output will change if you set the mode switch afterwards. This could possibly trigger other connected instruments or devices.

6.2 Adjustment elements

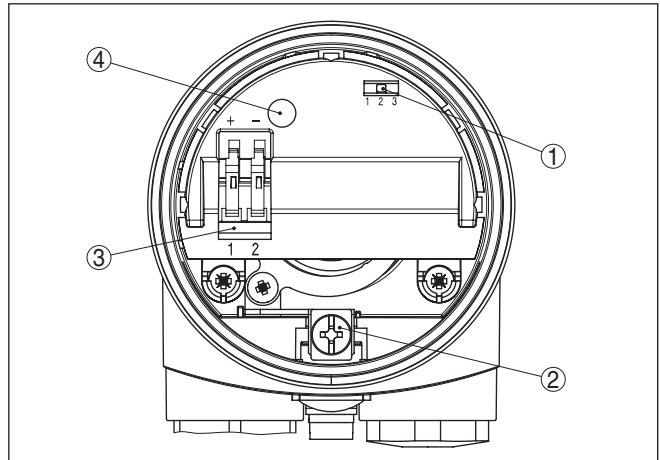

Fig. 14: Electronics module - Two-wire output

- 1 DIL switch for measuring range selection (with compensation button)
- 2 Ground terminal
- 3 Connection terminals
- 4 Control lamp

A failure can be displayed when the housing is closed (only plastic housing).

Take note of the switching point adjustment of the operating instructions of the "Controller".



Note:

Screw the housing cover tightly up to the thread stop so that the inspection glass is above the control lamp (LED).

To adjust VEGACAP 67, first of all remove the housing cover.

Measuring range selection switch (1)

With the potentiometer on the controller and the measuring range selection switch (1) on VEGACAP 67 you can change the sensitivity of the probe to the electrical properties of the product and the conditions in the vessel. This is necessary so that the level switch can also reliably detect products e.g. with very low or very high dielectric figure.

range 1: 0 ... 20 pF

Range 2: 0 ... 85 pF

Range 3: 0 ... 450 pF

Signal lamp (4)

Control lamp for indication of the device status.

- green = instrument functions
- red (flashing) = failure

See operating instructions manual of the " *Controller*".

Switching point adjustment

The adjustment of the switching point is only possible in installed condition.

Standing capacitances in a vessel can influence the measurement. We therefore recommend to carry out a compensation of these standing capacitances before the adjustment.

1. Make sure that the probe is correctly mounted and connected.
2. Make sure that the probe is uncovered.

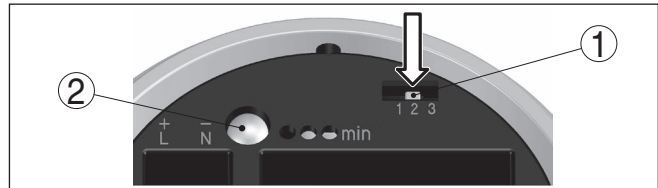

Fig. 15: Compensation key

- 1 Measuring range selection switch (compensation key)
- 2 Control lamp

3. Keep the measuring range selection switch (1) pushed until the control lamp (2) flashes green.
4. Then carry out the adjustment.

The detailed adjustment of VEGACAP 67 is described in the operating instructions manual of the " *Controller*".

7 Diagnostics and servicing

7.1 Maintenance

Maintenance

If the device is used properly, no special maintenance is required in normal operation.

Cleaning

The cleaning helps that the type label and markings on the instrument are visible.

Take note of the following:

- Use only cleaning agents which do not corrode the housings, type label and seals
- Use only cleaning methods corresponding to the housing protection rating

7.2 Rectify faults

Reaction when malfunction occurs

The operator of the system is responsible for taking suitable measures to rectify faults.

Causes of malfunction

The device offers maximum reliability. Nevertheless, faults can occur during operation. These may be caused by the following, e.g.:

- Sensor
- Process
- Voltage supply
- Signal processing

Fault rectification

The first measure to take is to check the output signal. In many cases, the causes can be determined this way and the faults quickly rectified.

Reaction after fault rectification

Depending on the reason for the fault and the measures taken, the steps described in chapter " *Setup* " must be carried out again or must be checked for plausibility and completeness.

24 hour service hotline

Should these measures not be successful, please call in urgent cases the VEGA service hotline under the phone no. **+49 1805 858550**.

The hotline is also available outside normal working hours, seven days a week around the clock.

Since we offer this service worldwide, the support is provided in English. The service itself is free of charge, the only costs involved are the normal call charges.

Checking the switching signal

Error	Cause	Rectification
<ul style="list-style-type: none"> ● The instrument signals covered without being covered by the measured medium ● The instrument signals uncovered while covered with the measured medium 	Wrong mode selected on the controller	Set the correct mode on the mode switch of the controller (A: overflow protection, B: dry run protection). Wiring should be carried out according to the idle current principle.
	Operating voltage too low	Check operating voltage
	Shortcircuit in the probe, e.g. because of moisture in the housing	Remove the electronics module. Check the resistance between the marked plug connections. See the following instructions.
	Electronics defective	Push the mode switch (A/B) on the controller. If the controller then changes the mode, the probe may be mechanically damaged. Should the switching function in the correct mode still be faulty, return the probe for repair. Check if there is buildup on the probe, and if so, remove it.
	Unfavourable installation location	Check if the probe is covered by buildup on the nozzle. Mount the instrument at a location in the vessel where e.g. no mounds can form.
Signal lamp flashes red	Electronics module has detected a failure	Exchange the instrument or send it in for repair

Check the resistance in the probe

Remove the electronics module. Check the resistance between the two plug connections.

There must no longer be a connection (high impedance). If there is still a connection, exchange the instrument or return it for repair

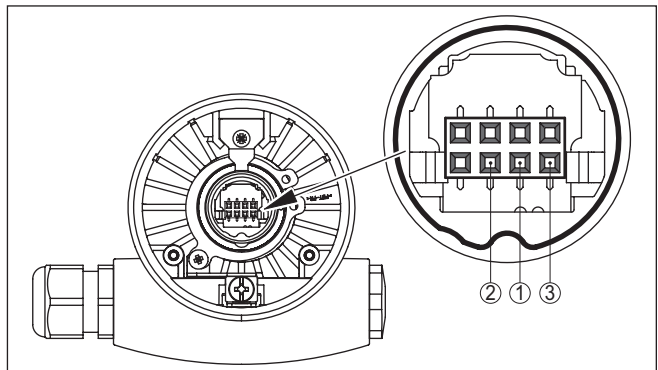

Fig. 16: Check the resistance in the probe

- 1 Shielding
- 2 Measuring probe
- 3 Ground potential

7.3 Exchange of the electronics module

In general, all oscillators of series CP60 can be interchanged.

If you want to use an electronics module with a different signal output, you can download the corresponding operating instructions manual on our homepage under Downloads.

Electronic versions with specific factory settings (e.g. foam detection) can only be exchanged for identical electronic versions.

Proceed as follows:

1. Switch off voltage supply
2. Unscrew the housing lid
3. Lift the opening levers of the terminals with a screwdriver
4. Pull the connection cables out of the terminals
5. Loosen the two screws with a screw driver (Torx size T10 or slot 4)

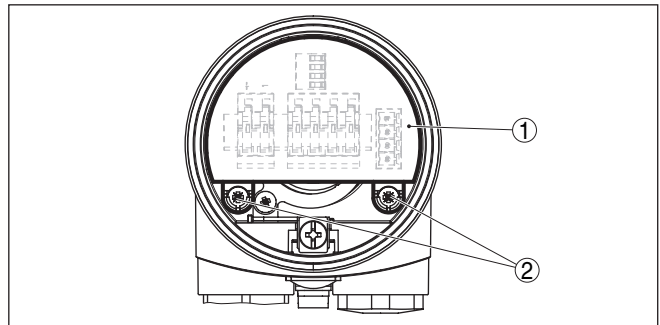

Fig. 17: Loosen the holding screws

- 1 Electronics module
- 2 Screws (2 pcs.)

6. Pull out old electronics module
7. Compare the new electronics module with the old one. The type label of the electronics module must correspond to that of the old electronics module. This applies particularly to instruments used in hazardous areas.
8. Compare the settings of the two electronics modules. Set the adjustment elements of the new electronics module to the same setting of the old one.

i Information:

Make sure that the housing is not rotated during the electronics exchange. Otherwise the plug may be in a different position later.

9. Insert the electronics module carefully. Make sure that the plug is in the correct position.
10. Screw in and tighten the two holding screws with a screwdriver (Torx size T10 or Phillips 4)
11. Insert the wire ends into the open terminals according to the wiring plan
12. Press down the opening levers of the terminals, you will hear the terminal spring closing

13. Check the hold of the wires in the terminals by lightly pulling on them
14. Check cable gland on tightness. The seal ring must completely encircle the cable.
15. Mount the probe into the vessel. Make sure that the probe is uncovered.

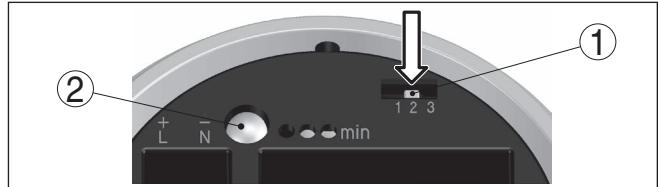

Fig. 18: Compensation key

- 1 Measuring range selection switch (compensation key)
- 2 Control lamp

16. Keep the measuring range selection switch (1) pushed until the control lamp (2) flashes green.
 17. Carry out the adjustment again. See chapter "Set-up, adjustment elements".
 18. Screw the housing lid back on
- The electronics exchange is now finished.

7.4 Shortening of the probe

The rod of the probe can be shortened to any length.

1. Shorten the rod probe to the requested length with a metal saw.
2. Mount the probe into the vessel. Make sure that the probe is uncovered.

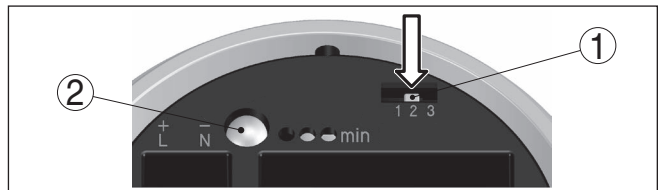

Fig. 19: Compensation key

- 1 Measuring range selection switch (compensation key)
- 2 Control lamp

3. Keep the measuring range selection switch (1) pushed until the control lamp (2) flashes green.
4. Hence the probe is compensated to the modified length.
5. Carry out the adjustment again. See chapter "Set-up, adjustment elements".

7.5 How to proceed if a repair is necessary

You can find an instrument return form as well as detailed information about the procedure in the download area of our homepage. By doing this you help us carry out the repair quickly and without having to call back for needed information.

Proceed as follows in case of repair:

- Print and fill out one form per instrument
- Clean the instrument and pack it damage-proof
- Attach the completed form and, if need be, also a safety data sheet outside on the packaging
- Ask the agency serving you to get the address for the return shipment. You can find the agency on our homepage.

8 Dismount

8.1 Dismounting steps

**Warning:**

Before dismantling, be aware of dangerous process conditions such as e.g. pressure in the vessel or pipeline, high temperatures, corrosive or toxic media etc.

Take note of chapters "*Mounting*" and "*Connecting to voltage supply*" and carry out the listed steps in reverse order.

8.2 Disposal



Pass the instrument on to a specialised recycling company and do not use the municipal collecting points.

Remove any batteries in advance, if they can be removed from the device, and dispose of them separately.

If personal data is stored on the old device to be disposed of, delete it before disposal.

If you have no way to dispose of the old instrument properly, please contact us concerning return and disposal.

9 Supplement

9.1 Technical data

Note for approved instruments

The technical data in the respective safety instructions which are included in delivery are valid for approved instruments (e.g. with Ex approval). These data can differ from the data listed herein, for example regarding the process conditions or the voltage supply.

All approval documents can be downloaded from our homepage.

General data

Material 316L corresponds to 1.4404 or 1.4435

Process fitting G1½, 1½ NPT

Materials, wetted parts

- Process fitting - thread 316L
- Process fitting - flange 316L
- Process seal Klingersil C-4400
- Insulation (partly insulated) Ceramic (KER 221 according to DIN 40685)
- Probe - rod, ceramic partly insulated 316L
(ø 15 mm/0.591 in)
- Probe - cable, ceramic partly insulated 316 (1.4401)
(ø 8 mm/0.315 in) ¹⁾
- Gravity weight 316L

Materials, non-wetted parts

- Plastic housing Plastic PBT (Polyester)
- Aluminium die-cast housing Aluminium die-casting AlSi10Mg, powder-coated (Basis: Polyester)
- Stainless steel housing (precision casting) 316L
- Stainless steel housing (electropolished) 316L
- Seal between housing and housing lid Silicone
- Ground terminal 316L
- Cable gland PA, stainless steel, brass
- Sealing, cable gland NBR
- Blind plug, cable gland PA

Process fittings

- Pipe thread, cylindrical (DIN 3852-A) G1½
- Pipe thread, conical (ASME B1.20.1) 1½ NPT
- Flanges DIN from DN 40, ASME from 1½"

Weight

- Instrument weight (depending on process fitting) 0.8 ... 4 kg (0.18 ... 8.82 lbs)

¹⁾ Cable connected electrically conductive with the gravity weight.

– Gravity weight	1800 g (64 oz)
– Rod weight: \varnothing 15 mm (0.591 in)	1400 g/m (15 oz/ft)
– Cable weight: \varnothing 8 mm (0.315 in)	400 g/m (4.3 oz/ft)
Sensor length (L)	
– Rod (\varnothing 15 mm/0.591 in)	0.275 ... 6 m (0.902 ... 19.69 ft)
– Cable (\varnothing 8 mm/0.315 in)	0.53 ... 40 m (1.74 ... 131.23 ft)
Supporting tube length L1	0.2 ... 5.6 m (0.656 ... 18.37 ft)
Max. lateral load	10 Nm (7.4 lbf ft)
Max. tensile load (cable)	
– Ceramic partly insulated: \varnothing 8 mm (0.315 in)	10 KN (2248 lbf)
Max. torque (process fitting - thread)	80 Nm (58 lbf ft)
Torque for NPT cable glands and Conduit tubes	
– Plastic housing	max. 10 Nm (7.376 lbf ft)
– Aluminium/Stainless steel housing	max. 50 Nm (36.88 lbf ft)
Measuring frequency	430 kHz

Output variable

Output	Two-wire output
Suitable controllers	VEGATOR 141, 142, 620, 621, 622
Output signal	> 4 ... < 20 mA (not standardised)
Fault message	< 2.3 mA
Switching delay	
– When immersed	0.7 s
– When laid bare	0.7 s
– In the event of a fault	1 s

Measurement accuracy (according to DIN EN 60770-1)

Reference conditions according to DIN EN 61298-1

– Temperature	+18 ... +30 °C (+64 ... +86 °F)
– Relative humidity	45 ... 75 %
– Air pressure	+860 ... +1060 mbar/+86 ... +106 kPa (+12.5 ... +15.4 psig)

Deviation due to strong, high-frequency electromagnetic fields acc. to EN 61326 < 3 % of the adjusted measuring range ²⁾Influence of the ambient temperature < 0.15 %/10 K of the adjusted measuring range ³⁾

Ambient conditions

Ambient temperature on the housing	-40 ... +80 °C (-40 ... +176 °F)
Storage and transport temperature	-40 ... +80 °C (-40 ... +176 °F)

²⁾ Distance from the process fittings to the set switching point.³⁾ Distance from the process fittings to the set switching point.

Process conditions

Process pressure	-1 ... 16 bar/-100 ... 1600 kPa (-14.5 ... 232 psig)
Process temperature (thread or flange temperature)	
- Standard	-50 ... +300 °C (-58 ... +572 °F)
- with external housing	-50 ... +400 °C (-58 ... +752 °F)

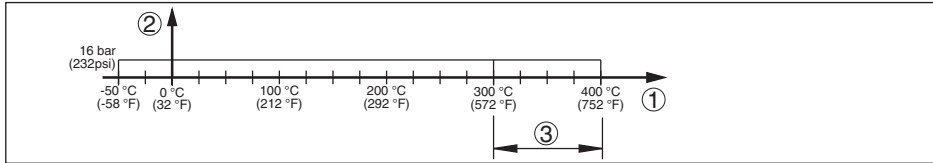

Fig. 20: Process temperature - Process pressure

- 1 Process temperature
- 2 Process pressure
- 3 Temperature range with external housing

Dielectric constant	≥ 1.5
---------------------	-------

Electromechanical data - version IP66/IP67 and IP66/IP68 (0.2 bar)

Options of the cable entry

- Cable entry	M20 x 1.5; ½ NPT
- Cable gland	M20 x 1.5; ½ NPT
- Blind plug	M20 x 1.5; ½ NPT
- Closing cap	½ NPT

Wire cross-section (spring-loaded terminals)

- Massive wire, stranded wire	0.2 ... 2.5 mm ² (AWG 24 ... 14)
- Stranded wire with end sleeve	0.2 ... 1.5 mm ² (AWG 24 ... 16)

Electromechanical data - version IP66/IP68 (1 bar)

Options of the cable entry

- Cable entry	M20 x 1.5; ½ NPT
- Cable gland	M20 x 1.5; ½ NPT
- Blind plug	M20 x 1.5; ½ NPT
- Closing cap	½ NPT

Connection cable

- Wire cross-section	> 0.5 mm ² (AWG 20)
- Wire resistance	< 0.036 Ω/m (0.011 Ω/ft)
- Tensile strength	< 1200 N (270 lbf)
- Standard length	5 m (16.4 ft)
- Max. length	1000 m (3280 ft)
- Min. bending radius	25 mm (0.984 in) with 25 °C (77 °F)
- Diameter approx.	8 mm (0.315 in)
- Colour - standard PE	Black
- Colour - standard PUR	Blue

– Colour - Ex-version Blue

Adjustment elements

DIL switch for measuring range selection

- range 1 0 ... 20 pF
- range 2 0 ... 85 pF
- range 3 0 ... 450 pF

Voltage supply

Operating voltage 10 ... 36 V DC (via the controller)

Electrical protective measures

Protection rating A suitable cable is required for maintaining the protection rating.

Housing material	Protection acc. to IEC 60529	Protection acc. to NEMA
Plastic	IP66/IP67	Type 4X
Aluminium	IP66/IP68 (0.2 bar)	Type 6P
	IP68 (1 bar)	Type 6P
Stainless steel (electro-polished)	IP66/IP68 (0.2 bar)	Type 6P
	IP68 (1 bar)	Type 6P
Stainless steel (precision casting)	IP66/IP68 (0.2 bar)	Type 6P
	IP68 (1 bar)	Type 6P

Altitude above sea level up to 5000 m (16404 ft)

Protection class II

9.2 Dimensions

The following dimensional drawings represent only an extract of all possible versions. Detailed dimensional drawings can be downloaded at www.vega.com/downloads under "Drawings".

Housing in protection IP66/IP67 and IP66/IP68 (0.2 bar)

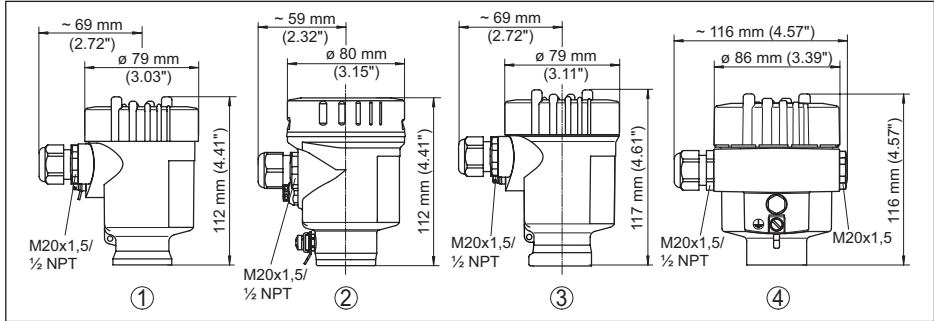

Fig. 21: Housing versions in protection IP66/IP67 and IP66/IP68 (0.2 bar)

- 1 Plastic single chamber
- 2 Stainless steel single chamber (electropolished)
- 3 Stainless steel single chamber (precision casting)
- 4 Aluminium - single chamber

Housing in protection IP66/IP68 (1 bar)

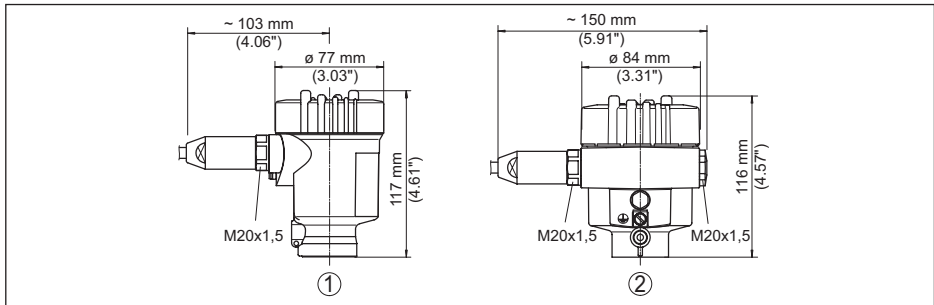

Fig. 22: Housing versions with protection rating IP66/IP68 (1 bar)

- 1 Stainless steel single chamber (precision casting)
- 2 Aluminium - single chamber

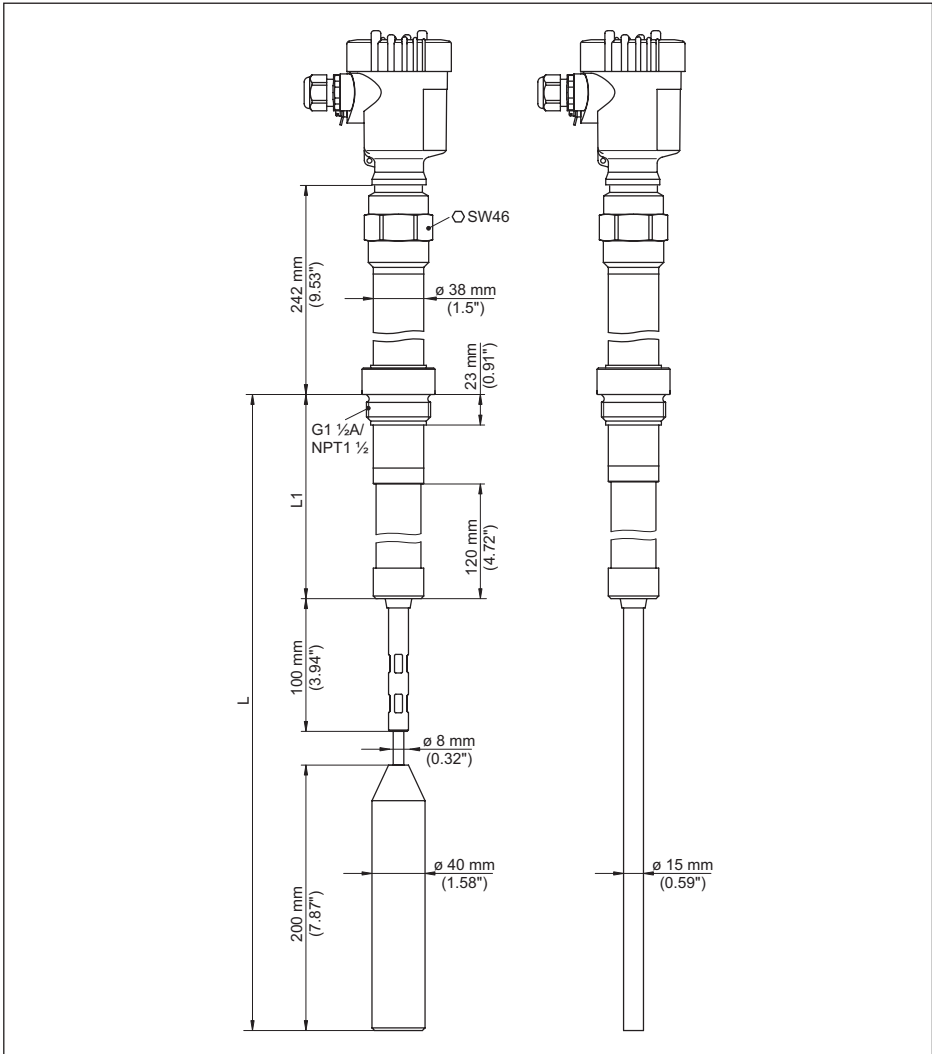

Fig. 23: VEGACAP 67, threaded version $G1\frac{1}{2}$ (ISO 228 T1) and $1\frac{1}{2}$ NPT, $-50 \dots +300 \text{ }^{\circ}\text{C}$ ($-58 \dots +572 \text{ }^{\circ}\text{F}$)

Version $-50 \dots +400 \text{ }^{\circ}\text{C}$ ($-58 \dots +752 \text{ }^{\circ}\text{F}$) only with external housing.

See supplementary instructions manual "External housing - VEGACAP, VEGACAL"

L Sensor length, see chapter "Technical data"

L1 Supporting tube length, see chapter "Technical data"

9.3 Industrial property rights

VEGA product lines are global protected by industrial property rights. Further information see www.vega.com.

VEGA Produktfamilien sind weltweit geschützt durch gewerbliche Schutzrechte.

Nähere Informationen unter www.vega.com.

Les lignes de produits VEGA sont globalement protégées par des droits de propriété intellectuelle. Pour plus d'informations, on pourra se référer au site www.vega.com.

VEGA lineas de productos están protegidas por los derechos en el campo de la propiedad industrial. Para mayor información revise la pagina web www.vega.com.

Линии продукции фирмы ВЕГА защищаются по всему миру правами на интеллектуальную собственность. Дальнейшую информацию смотрите на сайте www.vega.com.

VEGA系列产品在全球享有知识产权保护。

进一步信息请参见网站 < www.vega.com。

9.4 Trademark

All the brands as well as trade and company names used are property of their lawful proprietor/originator.

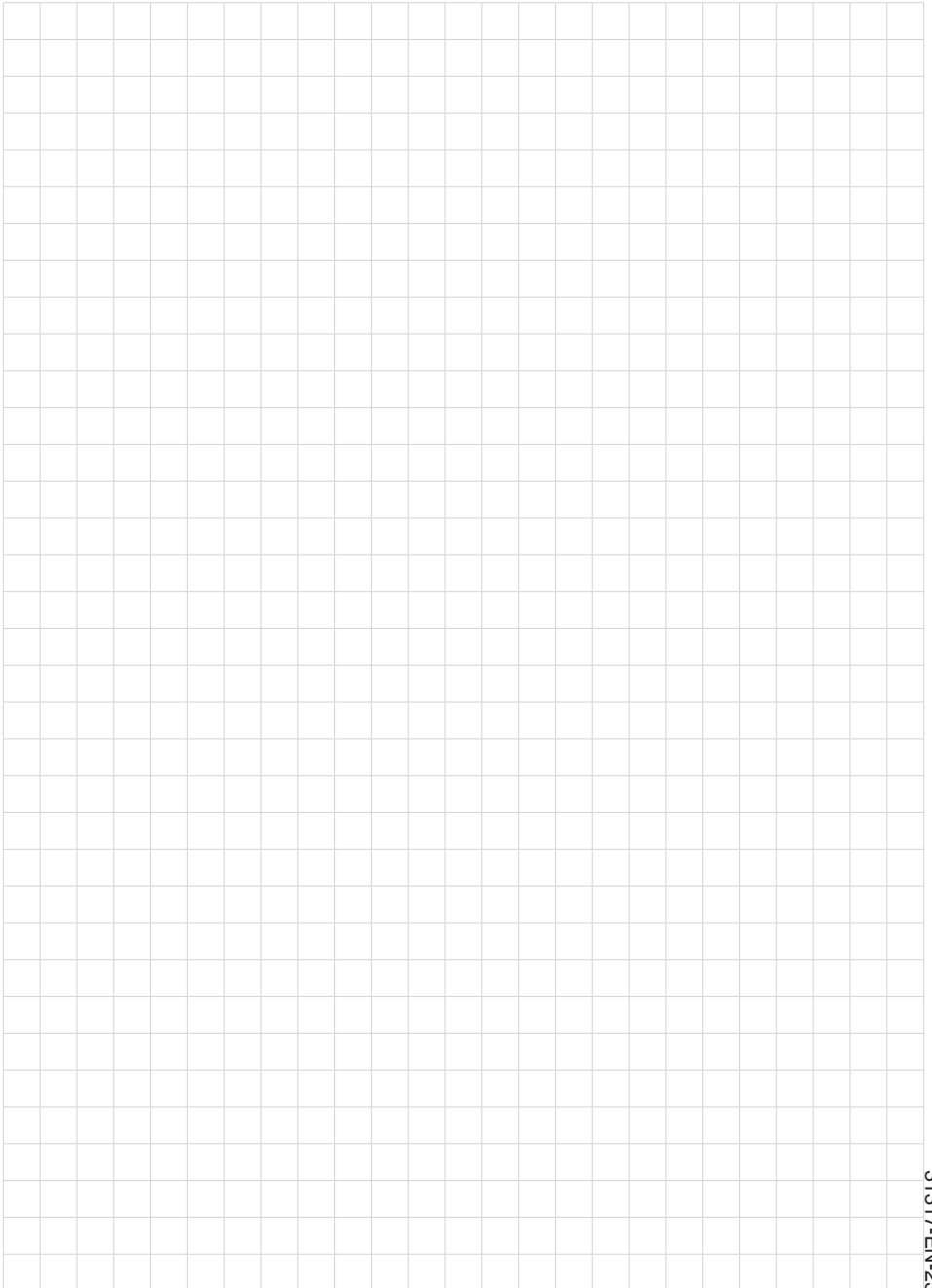

A large grid of 24 columns and 40 rows, intended for taking notes. The grid is composed of thin grey lines forming small squares.

31317-EN-230510



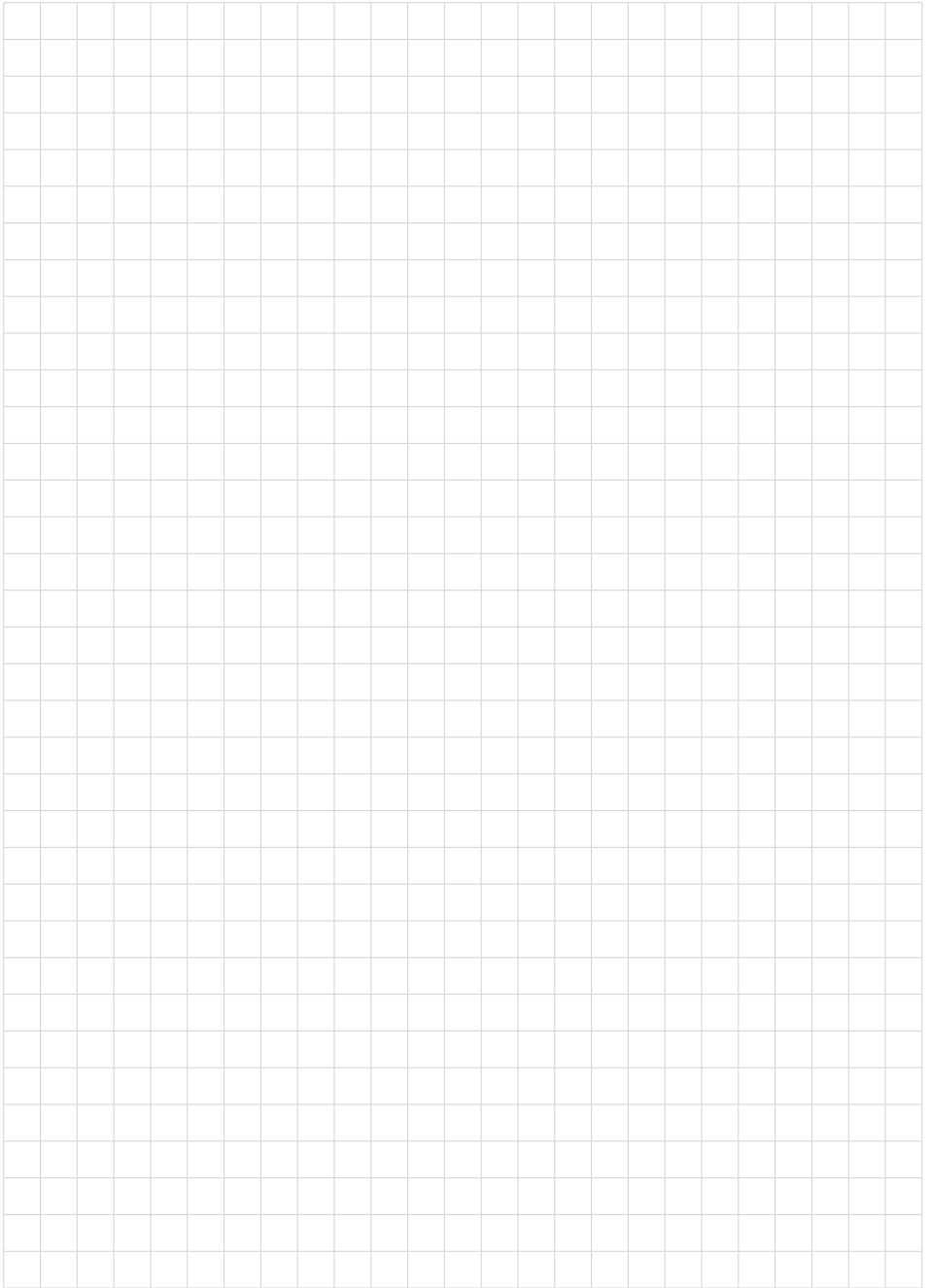

31317-EN-230510

Printing date:

VEGA

All statements concerning scope of delivery, application, practical use and operating conditions of the sensors and processing systems correspond to the information available at the time of printing.

Subject to change without prior notice

© VEGA Grieshaber KG, Schiltach/Germany 2023



31317-EN-230510

VEGA Grieshaber KG
Am Hohenstein 113
77761 Schiltach
Germany

Phone +49 7836 50-0
E-mail: info.de@vega.com
www.vega.com