

Operating Instructions

Electronics module

VEGACAL series 60

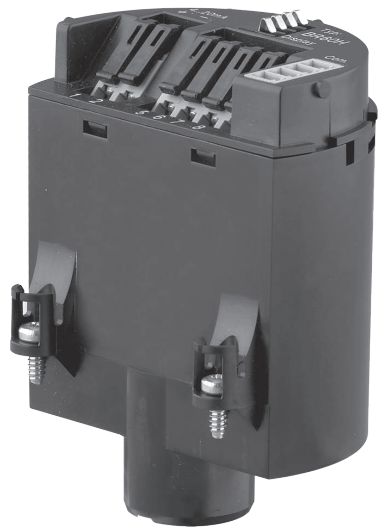

Document ID: 30531



VEGA

Contents

1	About this document	
1.1	Function	3
1.2	Target group	3
1.3	Symbols used.....	3
2	For your safety	
2.1	Authorised personnel	4
2.2	Appropriate use.....	4
2.3	Safety instructions for Ex areas	4
2.4	Environmental instructions	4
3	Product description	
3.1	Configuration.....	5
3.2	Principle of operation.....	5
3.3	Packaging, transport and storage.....	5
4	Mounting	
4.1	General instructions	6
4.2	Mounting preparations VEGACAL	6
4.3	Installation procedure	7
5	Setup	
5.1	Setup - Electronics 4 ... 20 mA, Profibus PA, Foundation Fieldbus	9
5.2	Setup - electronics with signal conditioning instrument	9
6	Maintenance	
6.1	How to proceed if a repair is necessary.....	10
7	Dismount	
7.1	Dismounting steps.....	11
7.2	Disposal	11
8	Supplement	
8.1	Technical data	12

1 About this document

1.1 Function

This operating instructions manual provides all the information you need for mounting, connection and setup of the instrument. Furthermore there are important instructions for maintenance, fault rectification, the exchange of parts and the safety of the user. Please read this information before putting the instrument into operation and keep this manual accessible in the immediate vicinity of the device.

1.2 Target group

This operating instructions manual is directed to trained specialist personnel. The contents of this manual should be made available to these personnel and put into practice by them.

1.3 Symbols used



Information, tip, note

This symbol indicates helpful additional information.



Caution: If this warning is ignored, faults or malfunctions can result.



Warning: If this warning is ignored, injury to persons and/or serious damage to the instrument can result.



Danger: If this warning is ignored, serious injury to persons and/or destruction of the instrument can result.



Ex applications

This symbol indicates special instructions for Ex applications.



SIL applications

This symbol indicates instructions for functional safety which must be taken into account particularly for safety-relevant applications.

- **List**

The dot set in front indicates a list with no implied sequence.

- **Action**

This arrow indicates a single action.

- 1 **Sequence of actions**

Numbers set in front indicate successive steps in a procedure.



Battery disposal

This symbol indicates special information about the disposal of batteries and accumulators.

2 For your safety

2.1 Authorised personnel

All operations described in this operating instructions manual must be carried out only by trained specialist personnel authorised by the plant operator.

During work on and with the device the required personal protective equipment must always be worn.

2.2 Appropriate use

Electronics module, emitting electronics, housing or process components are replacement components for existing sensors.

2.3 Safety instructions for Ex areas

Please note the Ex-specific safety information for installation and operation in Ex areas. These safety instructions are part of the operating instructions manual and come with the Ex-approved instruments.

2.4 Environmental instructions

Protection of the environment is one of our most important duties. That is why we have introduced an environment management system with the goal of continuously improving company environmental protection. The environment management system is certified according to DIN EN ISO 14001.

Please help us fulfil this obligation by observing the environmental instructions in this manual:

- Chapter "*Packaging, transport and storage*"
- Chapter "*Disposal*"

3 Product description

3.1 Configuration

Scope of delivery

The scope of delivery encompasses:

- Electronics module VEGACAL series 60
- Documentation
 - This operating instructions manual

3.2 Principle of operation

Application area

The electronics module CL 60 is suitable for exchange with capacitive sensors VEGACAL series 60.

3.3 Packaging, transport and storage

Packaging

Your instrument was protected by packaging during transport. Its capacity to handle normal loads during transport is assured by a test based on ISO 4180.

The packaging of standard instruments consists of environment-friendly, recyclable cardboard. For special versions, PE foam or PE foil is also used. Dispose of the packaging material via specialised recycling companies.

Transport

Transport must be carried out in due consideration of the notes on the transport packaging. Nonobservance of these instructions can cause damage to the device.

Transport inspection

The delivery must be checked for completeness and possible transit damage immediately at receipt. Ascertained transit damage or concealed defects must be appropriately dealt with.

Storage

Up to the time of installation, the packages must be left closed and stored according to the orientation and storage markings on the outside.

Unless otherwise indicated, the packages must be stored only under the following conditions:

- Not in the open
- Dry and dust free
- Not exposed to corrosive media
- Protected against solar radiation
- Avoiding mechanical shock and vibration

Storage and transport temperature

- Storage and transport temperature see chapter "*Supplement - Technical data - Ambient conditions*"
- Relative humidity 20 ... 85 %

Lifting and carrying

With an instrument weight of more than 18 kg (39.68 lbs) suitable and approved equipment must be used for lifting and carrying.

4 Mounting

4.1 General instructions

If the electronics module is defective, it can be replaced by the user.



In Ex applications, only instruments and electronics modules with appropriate Ex approval may be used.

If there is no electronics module available on site, one can be ordered from the VEGA agency serving you.

Sensor serial number

The new electronics module must be loaded with the order and factory data of the sensor. These are the options:

- At the factory by VEGA
- Or on site by the user



Information:

When loading on site, the order data must first be downloaded from the Internet (see "Setup").

In both cases, the sensor serial number is necessary. The serial numbers are stated on the type label of the instrument, inside the housing or on the delivery note.



Caution:

The order data and factory data contain important presettings for the sensor. Reliable operation and correct measurement are not possible without these data.

Assignment

Electronics modules are adapted to the respective sensor. They differ, e.g. in the signal output, the power supply or approval.

First of all check by means of the overview in chapter "*Mounting preparations*", if you are using the suitable electronics module. Compare the new electronics module with the existing one. The specifications on the type label must correspond. This applies mainly to instruments with approvals.



Warning:

Switch off voltage supply before starting the installation procedure. The replacement electronics may only be installed when the sensor is in a **de-energised state**. Non-observance will damage the electronics!

4.2 Mounting preparations VEGACAL

Electronics versions

Electronics module CL-E.60H. is suitable for VEGACAL - 4 ... 20mA/HART.

Electronics module CL-E.60P. is suitable for VEGACAL - Profibus PA.

Electronics module CL-E.60F. is suitable for VEGACAL - Foundation Fieldbus FF.

Electronics module CL-E.60X. suitable for VEGACAL - with signal conditioning instrument.

**Caution:**

In Ex applications only one instrument and one electronics module with respective Ex approval may be used. Check the specifications on the type label.

Installation procedure**4.3 Installation procedure**

The electronics module is located in the electronics compartment. The below illustrations show the respective position of the electronics compartment in a single or double chamber housing.

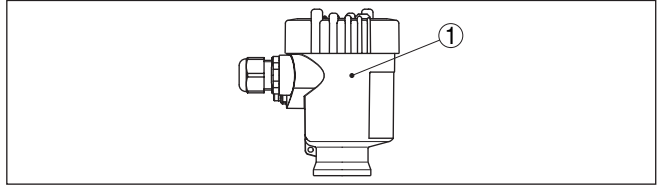

Fig. 1: Single chamber housing

1 Position of the electronics module

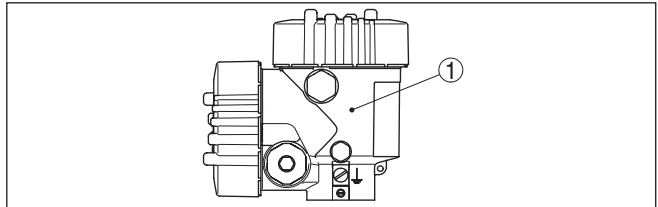

Fig. 2: Double chamber housing

1 Position of the electronics module

Proceed as follows:

1. Switch off power supply
2. Unscrew the lid of the electronics compartment
3. Disconnect the connection cables according to the operating instructions manual of the respective sensor
4. Loosen the two holding screws with a screwdriver (Torx size T 10 or Phillips size 4)

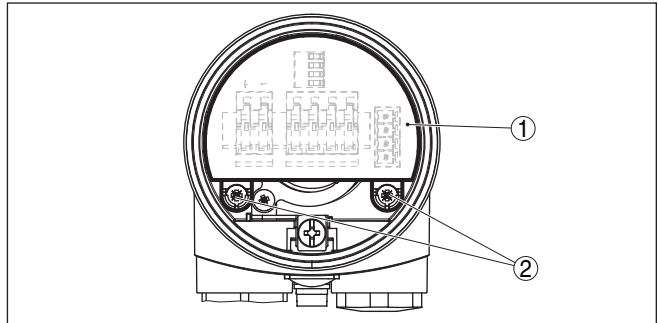

Fig. 3: Loosen the holding screws

- 1 Electronics module
- 2 Screws (2 pcs.)

5. Pull the previous electronics out with the opening levers.
6. Insert the new electronics module carefully.
7. Screw in the two holding screws and tighten them
8. Connect the connection cables according to the operating instructions manual of the respective sensor
9. Screw the housing lid back on

The electronics exchange is now finished.



As a rule, an exchange of electronics must be documented internally if Ex applications are involved.

5 Setup

5.1 Setup - Electronics 4 ... 20 mA, Profibus PA, Foundation Fieldbus

With sensor serial number

If you have ordered the electronics module **by stating the sensor serial number**, it is ready for operation after installation and connection to power supply.

Without sensor serial number

If you ordered the electronics module **without stating the sensor serial number** or you are using a suitable electronics module from stock, you first have to load the sensor data after installation.

Load sensor data

In general, the sensor with the new electronics module is ready for operation. However, the sensor name is "VEGACAL 62" (presetting) and the serial number is not entered correctly.

If these specifications should be correct, you have to enter the serial number.

Move to "www.vega.com", "*Instrument search (serial number)*". After entering the serial number, the order data of the sensor are displayed. The serial number is also available directly from VEGA.

Below the order data you will find "*Sensor data for Service-DTM*" as XML file. Load this file with "Save as" on your PC and transfer it then via PACTware and the Service DTM to the sensor.

Adjustment

As a rule, settings already carried out on site with the previous electronics module, such as min./max. adjustment etc., must be repeated.



Tip:

To do this, use the copy function of the display and adjustment module or the adjustment software PACTware.

5.2 Setup - electronics with signal conditioning instrument

Adjustment

Set all adjustment elements on the new electronics module to the settings of the old module.

Since the electronics modules are slightly different (approx. 5 %), it can be necessary to carry out an adjustment on the signal conditioning instrument after having exchanged the electronics.

6 Maintenance

6.1 How to proceed if a repair is necessary

You can find an instrument return form as well as detailed information about the procedure in the download area of our homepage: www.vega.com.

By doing this you help us carry out the repair quickly and without having to call back for needed information.

If a repair is necessary, please proceed as follows:

- Print and fill out one form per instrument
- Clean the instrument and pack it damage-proof
- Attach the completed form and, if need be, also a safety data sheet outside on the packaging
- Please contact the agency serving you to get the address for the return shipment. You can find the agency on our home page www.vega.com.

7 Dismount

7.1 Dismounting steps

Take note of chapters "*Mounting*" and "*Connecting to power supply*" and carry out the listed steps in reverse order.

7.2 Disposal

The replacement module consists of materials which can be recycled by specialised recycling companies. We have purposely designed the electronic modules to be easily separable.

WEEE directive 2002/96/EG

This instrument is not subject to the WEEE directive 2002/96/EG and the respective national laws (in Germany e.g. ElektroG). Pass the instrument directly on to a specialised recycling company and do not use the municipal collecting points. These may be used only for privately used products according to the WEEE directive.

Correct disposal avoids negative effects on humans and the environment and ensures recycling of useful raw materials.

Materials: see chapter "*Technical data*"

If you have no way to dispose of the replacement module properly, please contact us concerning return and disposal.

8 Supplement

8.1 Technical data

Technical data

are stated in the operating instructions manual of the respective sensor.

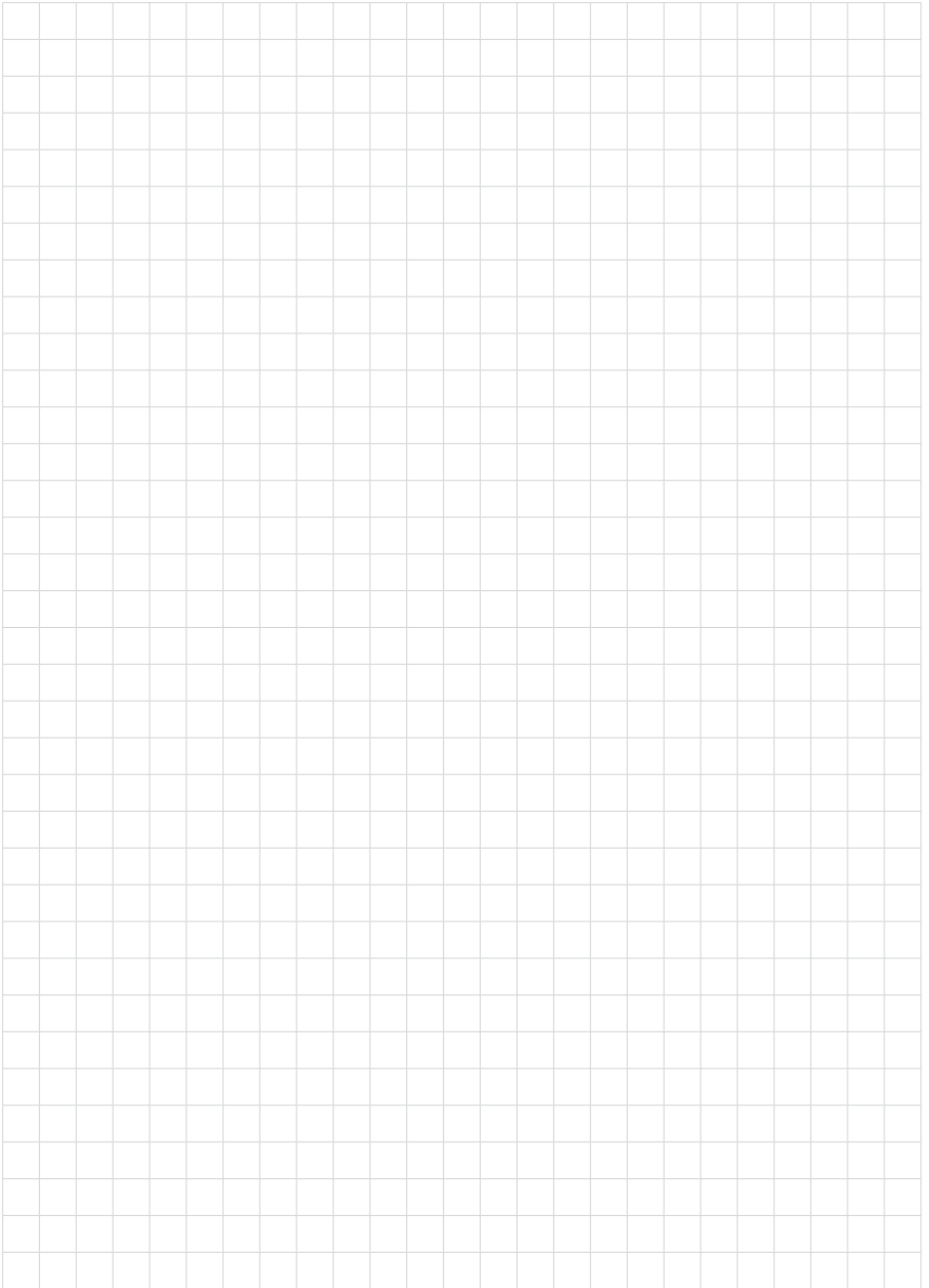

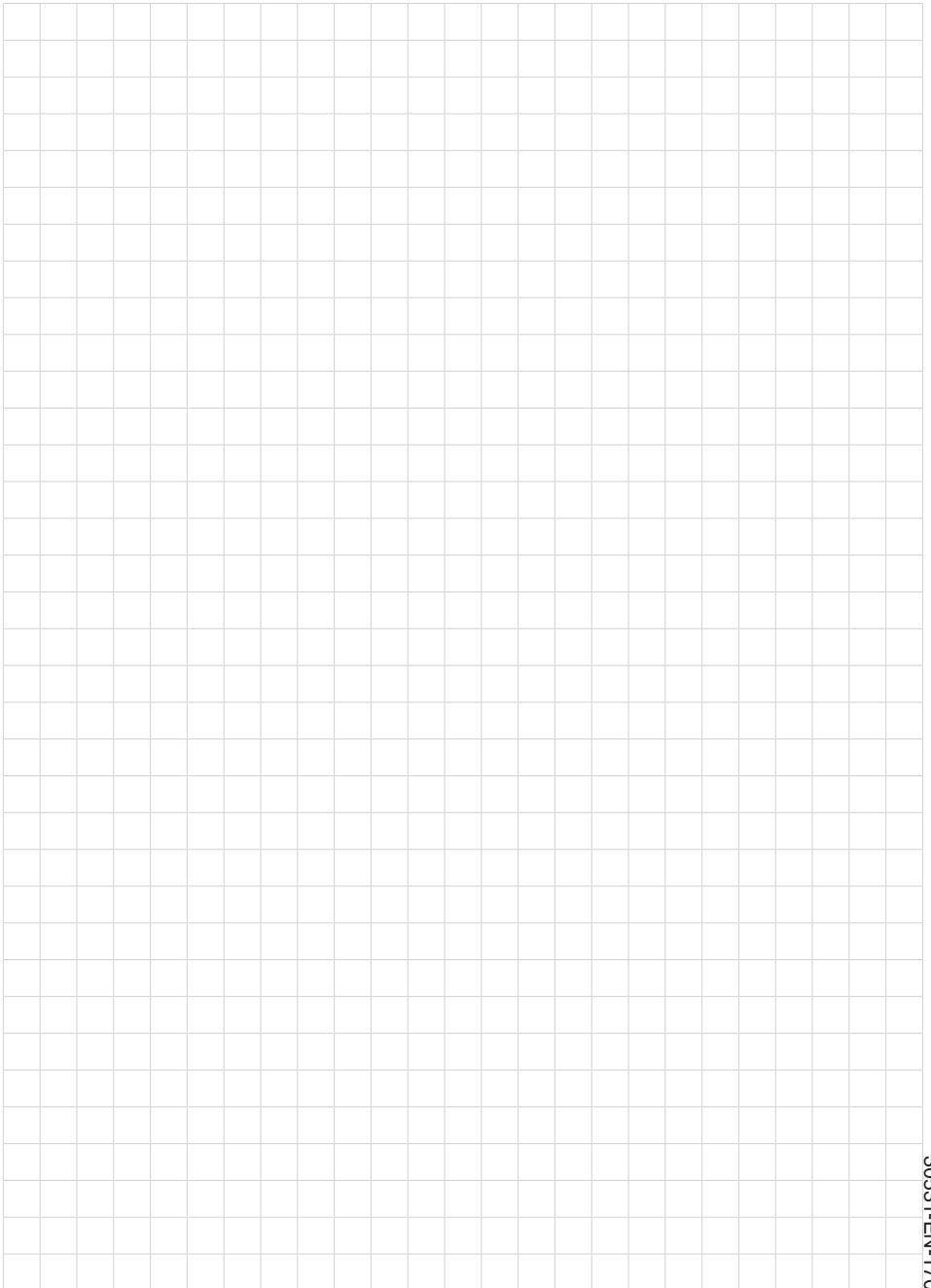



Printing date:

VEGA

All statements concerning scope of delivery, application, practical use and operating conditions of the sensors and processing systems correspond to the information available at the time of printing.

Subject to change without prior notice

© VEGA Grieshaber KG, Schiltach/Germany 2017



30531-EN-170531

VEGA Grieshaber KG
Am Hohenstein 113
77761 Schiltach
Germany

Phone +49 7836 50-0
Fax +49 7836 50-201
E-mail: info.de@vega.com
www.vega.com