

Supplementary instructions

Plug connector Harting HAN 8D

For point level sensors



Document ID: 30381



VEGA

Contents

1 For your safety	3
1.1 Appropriate use.....	3
1.2 General safety instructions	3
1.3 Safety instructions for Ex areas	3
2 Product description	4
3 Mounting	6
3.1 Mounting preparations	6
3.2 Installation procedure	6
4 Connecting to power supply.....	7
4.1 Wiring plan	7
5 Supplement	10
5.1 Technical data	10
5.2 Dimensions	11



Safety instructions for Ex areas

Please note the Ex-specific safety information for installation and operation in Ex areas. These safety instructions are part of the operating instructions and come with the Ex-approved instruments.

Editing status: 2019-09-17

1 For your safety

1.1 Appropriate use

The plug connectors belong to the accessories for level, switching and pressure sensors. They provide a detachable connection to power supply/signal processing for level switches.

1.2 General safety instructions

The safety information in the operating instructions manual of the respective sensor must be noted.

1.3 Safety instructions for Ex areas

Please note the Ex-specific safety information for installation and operation in Ex areas. These safety instructions are part of the operating instructions and come with the Ex-approved instruments.

For instruments with Exd or StEx approval, the use of plug connectors is not allowed.

2 Product description

Scope of delivery

The scope of delivery encompasses:

- Screwed housing with pin insert
- Connector housing with insert
- Contact sleeves for connector housing
- Documentation
 - This supplementary instructions manual

Function

The plug connector is an accessory part for sensors with single or double chamber housing. It is used as separable connection to power supply and signal processing.

Configuration

The plug connector consists of the screwed housing, the connection cable to the sensor electronics as well as the connector housing. The individual cores of the connection cable are marked with figures for the terminals of the electronics module. The connector housing is available in straight and bent version.

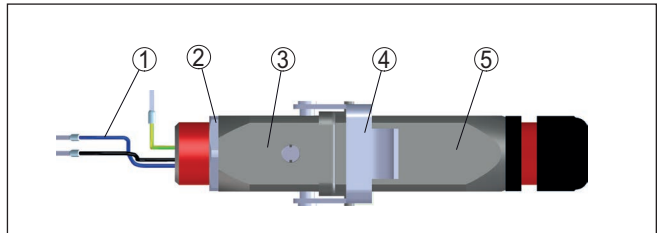

Fig. 1: Configuration plug connector Harting HAN 8D - Example straight version

- 1 Connection cable
- 2 Counter nut
- 3 Screwed housing
- 4 Locking clip
- 5 Connector housing

Versions

The plug is available in straight or bent version.

The bent version may only be used on the following houses:

- Stainless steel - precision cast housing
- Aluminium housing

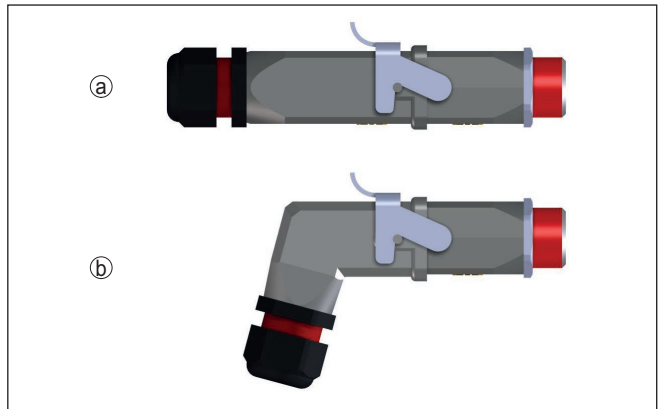

Fig. 2: Plug connector Harting HAN 8D - straight and bent version

a Straight version

b Bent version

Application area

The plug connector is used instead of the cable gland in the single or double chamber housing. It is available Ex factory, either integrated in the sensor or unassembled as retrofitting set.

3 Mounting

3.1 Mounting preparations

Tools

The following tools are required for mounting:

- Spanner SW 24 for unscrewing the cable gland
- Screwdriver SW 24 for tightening the counternut

3.2 Installation procedure

Position in the housing

The following illustration shows the position of the plug connector in the respective housing:

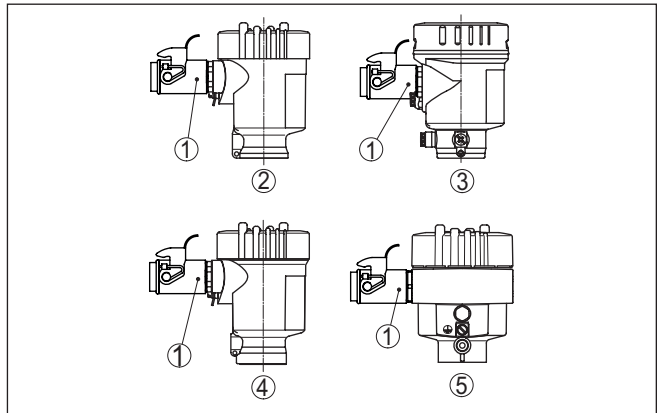

Fig. 3: Position of the plug connector on different instrument versions

- 1 Plug connector
- 2 Plastic single chamber
- 3 Stainless steel single chamber (electropolished)
- 4 Stainless steel single chamber (precision casting)
- 5 Aluminium - single chamber

Mounting of the plug connector

Proceed as follows to mount the plug connector:

1. Open the cover of the electronics or connection compartment
2. Unscrew the cable gland
3. Screw in the plug connector and secure it with the counternut
4. Connect the wires according to chapter "Connect"

The mounting of the plug connector is finished.

Disassembly is carried out in reverse order.

4 Connecting to power supply

4.1 Wiring plan

Each respective wiring plan shows the assignment of the individual pins of the plug connector to the respective signal outputs. The table shows the assignment of the individual contact pins to the terminals of the sensor electronics.

Transistor output

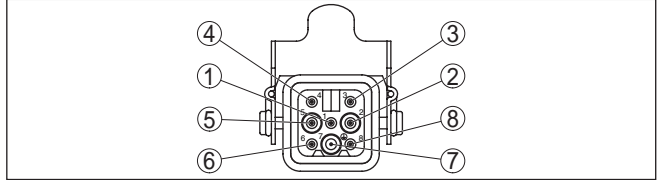



Fig. 4: Top view of the plug connector

- 1 + (Pin 1)
- 2 Transistor output (Pin 2)
- 3 Transistor output (Pin 3)
- 4 - (Pin 4)
- 5 free (Pin 5)
- 6 free (Pin 6)
- 7 free (Pin 7)
- 8 Screen (Pin 8)

Contact pin	Colour - connection cable	Terminal - electronics module		
		VEGACAP VEGAWAVE VEGAVIB VEGASWING VEGAKON	VEGAMIP R61, R62	VEGAMIP T61
Pin 1	Black	1	1	1
Pin 2	Blue	4	2	2
Pin 3	Red	3	7	-
Pin 4	Yellow	2	6	-
Pin 8	Green/Yellow			

Relay output

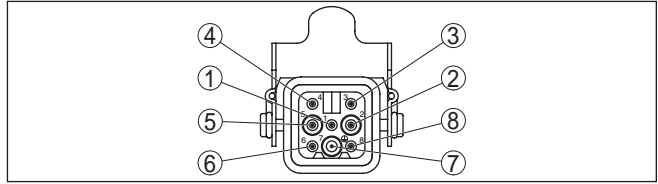



Fig. 5: Top view of the plug connector

- 1 + (Pin 1)
- 2 - (Pin 2)
- 3 free (Pin 3)
- 4 Relay output (Pin 4)
- 5 Relay output (Pin 5)
- 6 Relay output (Pin 6)
- 7 free (Pin 7)
- 8 Screen (Pin 8)

Contact pin	Colour - connection cable	Terminal - electronics module		
		VEGACAP VEGAWAVE VEGAVIB VEGASWING VEGAKON	VEGAMIP R61, R62	VEGAMIP T61
Pin 1	Black	1	1	1
Pin 2	Blue	2	2	2
Pin 4	Yellow	3	3	-
Pin 5	White	4	4	-
Pin 6	Grey	5	5	-
Pin 8	Green/Yellow			

Two-wire output, contactless electronic switch, NAMUR output

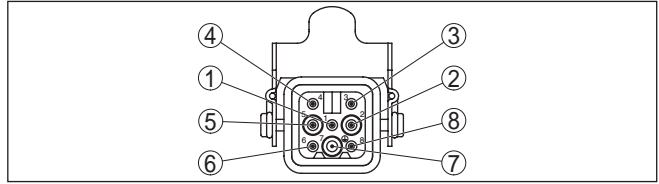



Fig. 6: Top view of the plug connector

- 1 + (Pin 1)
- 2 - (Pin 2)
- 3 free (Pin 3)
- 4 free (Pin 4)
- 5 free (Pin 5)
- 6 free (Pin 6)
- 7 free (Pin 7)
- 8 Screen (Pin 8)

Contact pin plug	Colour - connection cable	Terminal, electronics module
Pin 1	Black	1
Pin 2	Blue	2
Pin 8	Green/Yellow	

5 Supplement

5.1 Technical data

Materials

Contact support	Polyamide
Contact	copper alloy, hard silver plated 0.3 µm Ag
Plug and connector housing	Aluminium die-casting
Locking element	Metal
Cable gland	PA
Housing seal	NBR

Ambient conditions

Ambient temperature - plug connector, separate	-40 ... +125 °C (-40 ... +257 °F)
Ambient temperature - plug connector mounted to the sensor	The lower temperature is applicable

Electrical data acc. to EN 61010-1

Number of contacts	8
Operating voltage	20 ... 70 V DC 20 ... 33 V AC
Isolation resistance	≥ 10 ¹⁰ Ω
Rated current	10 A
Forward resistance	≤ 3 mΩ
Contact durability	≥ 500
Reference surge voltage	800 V
Pollution degree	3

Electrical protective measures

Protection rating - plug connector, separate in locked status	IP 65
Protection rating - plug connector mounted on the sensor	The lower protection category applies

5.2 Dimensions

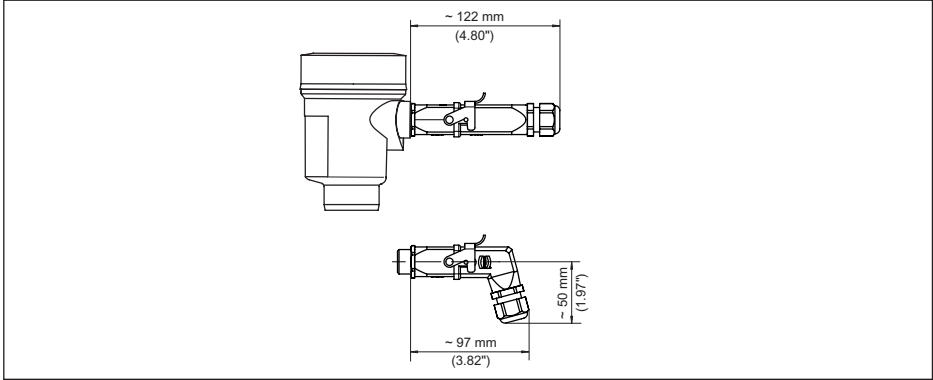

Fig. 7: Harting plug connector

Printing date:

VEGA

All statements concerning scope of delivery, application, practical use and operating conditions of the sensors and processing systems correspond to the information available at the time of printing.

Subject to change without prior notice

© VEGA Grieshaber KG, Schiltach/Germany 2019



30381-EN-190926

VEGA Grieshaber KG
Am Hohenstein 113
77761 Schiltach
Germany

Phone +49 7836 50-0
Fax +49 7836 50-201
E-mail: info.de@vega.com
www.vega.com