

Operating Instructions

Electronics module
VEGAVIB series 60

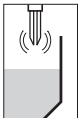

Contents

1 About this document

1.1 Function	4
1.2 Target group	4
1.3 Symbolism used.	4

2 For your safety

2.1 Authorised personnel	6
2.2 Appropriate use	6
2.3 Safety information for Ex areas	6
2.4 Environmental instructions.	6

3 Product description

3.1 Configuration	7
3.2 Principle of operation	7
3.3 Storage and transport.	7

4 Mounting

4.1 Mounting information	8
4.2 Mounting preparations	8
4.3 Mounting preparations	8

5 Setup

5.1 Setup	11
---------------------	----

6 Maintenance

6.1 Instrument repair	12
---------------------------------	----

7 Dismounting

7.1 Dismounting procedure.	13
7.2 Disposal	13

8 Supplement

8.1 Technical data	14
------------------------------	----

1 About this document

1.1 Function

This operating instructions manual has all the information you need for quick mounting and setup of a replacement component (electronics module, electronics or electronics with housing). Please read this manual before you start setup.

1.2 Target group

This operating instructions manual is directed to trained personnel. The contents of this manual should be made available to these personnel and put into practice by them.

1.3 Symbolism used



Information, tip, note

This symbol indicates helpful additional information.



Caution, warning, danger

This symbol informs you of a dangerous situation that could occur. Ignoring this cautionary note can impair the person and/or the instrument.



Ex applications

This symbol indicates special instructions for Ex applications.



List

The dot set in front indicates a list with no implied sequence.



Action

This arrow indicates a single action.

1 Sequence

Numbers set in front indicate successive steps in a procedure.

2 For your safety

2.1 Authorised personnel

All operations described in this operating instructions manual must be carried out only by trained specialist personnel authorised by the operator. For safety and warranty reasons, any internal work on the instruments must be carried out only by personnel authorised by the manufacturer.

2.2 Appropriate use

Electronics module VB 60 is a replacement module for vibrating level switches VEGAVIB series 60.

2.3 Safety information for Ex areas

Please note the Ex-specific safety information for installation and operation in Ex areas. These safety instructions are part of the operating instructions manual and come with the Ex-approved instruments.

2.4 Environmental instructions

Protection of the environment is one of our most important duties. That is why we have introduced an environment management system with the goal of continuously improving company environmental protection. The environment management system is certified acc. to DIN EN ISO 14001.

Please help us fulfil this obligation by observing the environmental instructions in this manual:

- Chapter "Storage and transport"
- Chapter "Disposal"

3 Product description

3.1 Configuration

Scope of delivery

The scope of delivery encompasses:

- Electronics module for VEGAVIB series 60 (VB 60)
- documentation
 - this operating instructions manual

3.2 Principle of operation

Area of application

Electronics module VB 60 is suitable for replacement in vibrating level switches VEGAVIB series 60.

3.3 Storage and transport

Packaging

Your instrument was protected by packaging during transport. Its capacity to handle normal loads during transport is assured by a test acc. to EN 24180.

The packaging of standard instruments consists of environment-friendly, recyclable cardboard. For special versions PE foam or PE foil is also used. Dispose of the packaging material via specialised recycling companies.

Storage and transport temperature

- Storage and transport temperature see Supplement, Technical data, Ambient conditions
- Relative humidity 20 ... 85 %

4 Mounting

4.1 Mounting information

If the electronics module is defective, it can be replaced by the user.



In Ex applications, only an instrument or oscillator with appropriate Ex approval must be used.

4.2 Mounting preparations

In general, all oscillators of series VB 60 can be exchanged. If you want to use an oscillator with a different signal output, you can download the corresponding operating instructions manual from our homepage under Downloads.

4.3 Mounting preparations

Mounting information

Proceed as follows to interchange the electronics module:

- 1 Switch off power supply
- 2 Unscrew the housing cover
- 3 Lift the opening levers of the terminals with a screwdriver
- 4 Pull the connection cables out of the terminals
- 5 Loosen the two screws with a Philips screwdriver (size 1)

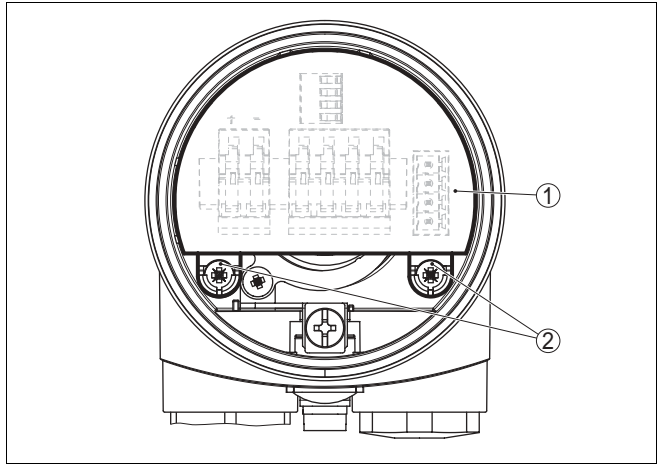

Fig. 1: Loosen the screws

- 1 Electronics module
- 2 Screws (2 pcs.)

- 6 Remove the old oscillator
- 7 Compare the new oscillator with the old one. The type label of the oscillator must correspond to that of the old oscillator. This applies particularly to instruments used in hazardous areas.
- 8 Compare the settings of the two oscillators. Set the adjustment elements of the new oscillator to the settings of the old oscillator.



Information:

- Make sure that the housing is not rotated during the electronics exchange. Otherwise the plug may be in a different position later.
- 9 Insert the oscillator carefully. Make sure that the plug is in the correct position.
 - 10 Screw in and tighten the two screws with a Philips screwdriver.
 - 11 Insert the wire ends into the open terminals according to the wiring plan
 - 12 Close the opening levers of the terminals, you will hear the terminal spring closing

13 Check the hold of the wires in the terminals by lightly pulling on them

14 Check the tightness of the cable entry. The seal ring must completely encircle the cable.

15 Screw the housing cover back on

The electronics exchange is finished.



As a rule, the exchange of the oscillator must be documented internally when used in Ex applications.

5 Setup

5.1 Setup

Setup

When exchanging the oscillator, set all adjustment elements to that of the old oscillator. The sensor is immediately ready for operation.

In general, all oscillators of series VB 60 can be exchanged.

If you want to use an oscillator with another signal output, you have to carry out the complete setup.

The necessary, suitable operating instructions manual can be downloaded from our homepage under Downloads.

Carry out the adjustment as described in the operating instructions manual.

6 Maintenance

6.1 Instrument repair

If it is necessary to repair the replacement component, please proceed as follows:

You can download a return form (23 KB) from our Internet homepage www.vega.com under "Services > Downloads > Forms and Certificates > Repair form.

By doing this you help us carry out the repair quickly and without having to call for additional information.

- Print and fill out one form per instrument
- Clean the instrument and pack it damage-proof
- Attach the completed form and possibly also a safety data sheet to the instrument
- Send the instrument to the respective address of your agency. In Germany to the VEGA headquarters in Schiltach.

7 Dismounting

7.1 Dismounting procedure

Take note of chapters "Mounting" and "Connecting to power supply" and carry out the listed steps in reverse order.

7.2 Disposal

The replacement component consists of materials which can be recycled by specialised recycling companies. We have purposely designed the electronic modules to be easily separable. Mark the instrument as scrap and dispose of it according to government regulations (electronic scrap ordinance, ...)

Materials: see Technical data

If you cannot dispose of the instrument properly, please contact us about disposal methods or return.

8 Supplement

8.1 Technical data

Technical data

see the operating instructions manual of the respective sensor.



VEGA Grieshaber KG
Am Hohenstein 113
77761 Schiltach
Germany
Phone +49 7836 50-0
Fax +49 7836 50-201
E-mail: info@de.vega.com
www.vega.com



All statements concerning scope of delivery, application, practical use and operating conditions of the sensors and processing systems correspond to the information available at the time of printing.