

# Operating Instructions

Ultrasonic sensor for continuous level measurement

## VEGASON 61

Four-wire 4 ... 20 mA/HART



Document ID: 28778



**VEGA**

# Contents

<b>1</b>	<b>About this document</b>	<b>4</b>
1.1	Function	4
1.2	Target group	4
1.3	Symbols used	4
<b>2</b>	<b>For your safety</b>	<b>5</b>
2.1	Authorised personnel	5
2.2	Appropriate use	5
2.3	Warning about incorrect use	5
2.4	General safety instructions	5
2.5	Conformity	5
2.6	Fulfillment of NAMUR recommendations	6
2.7	Installation and operation in the USA and Canada	6
2.8	Environmental instructions	6
<b>3</b>	<b>Product description</b>	<b>7</b>
3.1	Configuration	7
3.2	Principle of operation	8
3.3	Adjustment	8
3.4	Packaging, transport and storage	9
3.5	Accessories	9
<b>4</b>	<b>Mounting</b>	<b>11</b>
4.1	General instructions	11
4.2	Housing features	12
4.3	Mounting instructions	15
<b>5</b>	<b>Connecting to power supply</b>	<b>22</b>
5.1	Preparing the connection	22
5.2	Connection procedure	23
5.3	Wiring plan, double chamber housing	24
5.4	Switch-on phase	25
<b>6</b>	<b>Set up with the display and adjustment module PLICSCOM</b>	<b>27</b>
6.1	Insert display and adjustment module	27
6.2	Adjustment system	28
6.3	Setup steps	28
6.4	Menu schematic	41
6.5	Saving the parameterisation data	43
<b>7</b>	<b>Setup with PACTware</b>	<b>45</b>
7.1	Connect the PC via VEGACONNECT	45
7.2	Parameter adjustment	46
7.3	Save parameter adjustment data	47
<b>8</b>	<b>Set up with other systems</b>	<b>48</b>
8.1	DD adjustment programs	48
<b>9</b>	<b>Maintenance and fault rectification</b>	<b>49</b>
9.1	Maintenance	49
9.2	Rectify faults	49
9.3	Exchanging the electronics module	50
9.4	Software update	51
9.5	How to proceed if a repair is necessary	51

<b>10 Dismount.....</b>	<b>52</b>
10.1 Dismounting steps.....	52
10.2 Disposal .....	52
<b>11 Supplement .....</b>	<b>53</b>
11.1 Technical data .....	53
11.2 Dimensions .....	56
11.3 Industrial property rights.....	58
11.4 Trademark .....	58



**Safety instructions for Ex areas:**

Take note of the Ex specific safety instructions for Ex applications. These instructions are attached as documents to each instrument with Ex approval and are part of the operating instructions.

Editing status: 2023-10-24

# 1 About this document

## 1.1 Function

This instruction provides all the information you need for mounting, connection and setup as well as important instructions for maintenance, fault rectification, safety and the exchange of parts. Please read this information before putting the instrument into operation and keep this manual accessible in the immediate vicinity of the device.

## 1.2 Target group

This operating instructions manual is directed to trained personnel. The contents of this manual must be made available to the qualified personnel and implemented.

## 1.3 Symbols used



### Document ID

This symbol on the front page of this instruction refers to the Document ID. By entering the Document ID on [www.vega.com](http://www.vega.com) you will reach the document download.



**Information, note, tip:** This symbol indicates helpful additional information and tips for successful work.



**Note:** This symbol indicates notes to prevent failures, malfunctions, damage to devices or plants.



**Caution:** Non-observance of the information marked with this symbol may result in personal injury.



**Warning:** Non-observance of the information marked with this symbol may result in serious or fatal personal injury.



**Danger:** Non-observance of the information marked with this symbol results in serious or fatal personal injury.



### Ex applications

This symbol indicates special instructions for Ex applications.



### List

The dot set in front indicates a list with no implied sequence.



### Sequence of actions

Numbers set in front indicate successive steps in a procedure.



### Disposal

This symbol indicates special instructions for disposal.

## 2 For your safety

### 2.1 Authorised personnel

All operations described in this documentation must be carried out only by trained and authorized personnel.

During work on and with the device, the required personal protective equipment must always be worn.

### 2.2 Appropriate use

VEGASON 61 is a sensor for continuous level measurement.

You can find detailed information about the area of application in chapter "*Product description*".

Operational reliability is ensured only if the instrument is properly used according to the specifications in the operating instructions manual as well as possible supplementary instructions.

### 2.3 Warning about incorrect use

Inappropriate or incorrect use of this product can give rise to application-specific hazards, e.g. vessel overflow through incorrect mounting or adjustment. Damage to property and persons or environmental contamination can result. Also, the protective characteristics of the instrument can be impaired.

### 2.4 General safety instructions

This is a state-of-the-art instrument complying with all prevailing regulations and directives. The instrument must only be operated in a technically flawless and reliable condition. The operating company is responsible for the trouble-free operation of the instrument. When measuring aggressive or corrosive media that can cause a dangerous situation if the instrument malfunctions, the operating company has to implement suitable measures to make sure the instrument is functioning properly.

The safety instructions in this operating instructions manual, the national installation standards as well as the valid safety regulations and accident prevention rules must be observed.

For safety and warranty reasons, any invasive work on the device beyond that described in the operating instructions manual may be carried out only by personnel authorised by us. Arbitrary conversions or modifications are explicitly forbidden. For safety reasons, only the accessory specified by us must be used.

To avoid any danger, the safety approval markings and safety tips on the device must also be observed.

### 2.5 Conformity

The device complies with the legal requirements of the applicable country-specific directives or technical regulations. We confirm conformity with the corresponding labelling.

The corresponding conformity declarations can be found on our homepage.

### **Electromagnetic compatibility**

The instruments are designed for use in an industrial environment. Nevertheless, electromagnetic interference from electrical conductors and radiated emissions must be taken into account, as is usual with a class A instrument according to EN 61326-1. If the instrument is used in a different environment, its electromagnetic compatibility with other devices must be ensured by suitable measures.

## **2.6 Fulfilment of NAMUR recommendations**

NAMUR is the automation technology user association in the process industry in Germany. The published NAMUR recommendations are accepted as the standard in field instrumentation.

The device fulfils the requirements of the following NAMUR recommendations:

- NE 21: 2012 – Electromagnetic compatibility of equipment
- NE 43 – Signal level for fault information from measuring transducers
- NE 53 – Compatibility of field devices and display/adjustment components

For further information see [www.namur.de](http://www.namur.de).

## **2.7 Installation and operation in the USA and Canada**

This information is only valid for USA and Canada. Hence the following text is only available in the English language.

Installations in the US shall comply with the relevant requirements of the National Electrical Code (NEC - NFPA 70) (USA).

Installations in Canada shall comply with the relevant requirements of the Canadian Electrical Code (CEC Part I) (Canada).

## **2.8 Environmental instructions**

Protection of the environment is one of our most important duties. That is why we have introduced an environment management system with the goal of continuously improving company environmental protection. The environment management system is certified according to DIN EN ISO 14001.

Please help us fulfil this obligation by observing the environmental instructions in this manual:

- Chapter "*Packaging, transport and storage*"
- Chapter "*Disposal*"

### 3 Product description

#### 3.1 Configuration

**Scope of delivery**

The scope of delivery encompasses:

- Ultrasonic sensor

The further scope of delivery encompasses:

- Documentation
  - Quick setup guide VEGASON 61
  - Instructions for optional instrument features
  - Ex-specific "Safety instructions" (with Ex versions)
  - If necessary, further certificates



**Information:**

Optional instrument features are also described in this operating instructions manual. The respective scope of delivery results from the order specification.

**Constituent parts**

The VEGASON 61 consists of the components:

- Transducer with integrated temperature sensor
- Housing with electronics
- Housing cover, optionally available with display and adjustment module PLICSCOM

The components are available in different versions.

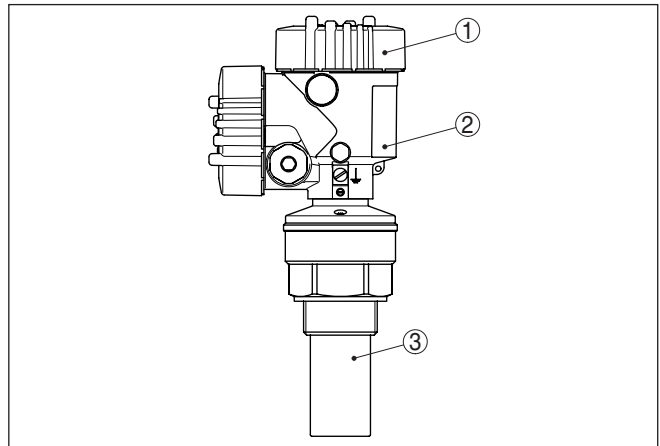

Fig. 1: VEGASON 61, Aluminium double chamber housing

- 1 Housing cover with integrated PLICSCOM (optional)
- 2 Housing with electronics, optionally available with plug connector
- 3 Process fitting with transducer

**Type label**

The type label contains the most important data for identification and use of the instrument:

- Instrument type
- Information about approvals

- Configuration information
- Technical data
- Serial number of the instrument
- QR code for device identification
- Numerical code for Bluetooth access (optional)
- Manufacturer information

**Documents and software** To find order data, documents or software related to your device, you have the following options:

- Move to "[www.vega.com](http://www.vega.com)" and enter in the search field the serial number of your instrument.
- Scan the QR code on the type label.
- Open the VEGA Tools app and enter the serial number under "**Documentation**".

### 3.2 Principle of operation

#### Application area

VEGASON 61 is an ultrasonic sensor for continuous level measurement. It is suitable for liquids and solids in virtually all industries, particularly in the water and waste water industry.

#### Functional principle

The transducer of the ultrasonic sensor transmits short ultrasonic pulses to the measured product. These pulses are reflected by medium surface and received back by the transducer as echoes. The running time of the ultrasonic pulses from emission to reception is proportional to the distance and hence the level. The determined level is converted into an appropriate output signal and outputted as measured value.

#### Voltage supply

Four-wire electronics with separate power supply.

The supply voltage range can differ depending on the instrument version.

The data for power supply are specified in chapter "*Technical data*".

Measured value transmission is carried out via the 4 ... 20 mA/HART output separate from power supply.

The backlight of the display and adjustment module is powered by the sensor. The prerequisite for this is a supply voltage at a certain level. The exact voltage specifications are stated in chapter "*Technical data*".

### 3.3 Adjustment

The instrument can be adjusted with the following adjustment media:

- With the display and adjustment module
- with the suitable VEGA DTM in conjunction with an adjustment software according to the FDT/DTM standard, e.g. PACTware and PC
- With manufacturer-specific adjustment programs AMS™ or PDM
- With a HART handheld



### 3.4 Packaging, transport and storage

**Packaging**

Your instrument was protected by packaging during transport. Its capacity to handle normal loads during transport is assured by a test based on ISO 4180.

The packaging of standard instruments consists of environment-friendly, recyclable cardboard. For special versions, PE foam or PE foil is also used. Dispose of the packaging material via specialised recycling companies.

**Transport**

Transport must be carried out in due consideration of the notes on the transport packaging. Nonobservance of these instructions can cause damage to the device.

**Transport inspection**

The delivery must be checked for completeness and possible transit damage immediately at receipt. Ascertained transit damage or concealed defects must be appropriately dealt with.

**Storage**

Up to the time of installation, the packages must be left closed and stored according to the orientation and storage markings on the outside.

Unless otherwise indicated, the packages must be stored only under the following conditions:

- Not in the open
- Dry and dust free
- Not exposed to corrosive media
- Protected against solar radiation
- Avoiding mechanical shock and vibration

**Storage and transport temperature**

- Storage and transport temperature see chapter "*Supplement - Technical data - Ambient conditions*"
- Relative moisture 20 ... 85 %

**Lifting and carrying**

With instrument weights of more than 18 kg (39.68 lbs) suitable and approved equipment must be used for lifting and carrying.

### 3.5 Accessories

The instructions for the listed accessories can be found in the download area on our homepage.

**Display and adjustment module**

The display and adjustment module is used for measured value indication, adjustment and diagnosis.

The integrated Bluetooth module (optional) enables wireless adjustment via standard adjustment devices.

**VEGACONNECT**

The interface adapter VEGACONNECT enables the connection of communication-capable instruments to the USB interface of a PC.

**VEGADIS 81**

The VEGADIS 81 is an external display and adjustment unit for VEGA plics® sensors.

<b>VEGADIS 82</b>	VEGADIS 82 is suitable for measured value indication and adjustment of sensors with HART protocol. It is looped into the 4 ... 20 mA/HART signal cable.
<b>PLICSMOBILE T81</b>	The PLICSMOBILE T81 is an external GSM/GPRS/UMTS radio unit for transmission of measured values and for remote parameter adjustment of HART sensors.
<b>Protective cover</b>	The protective cover protects the sensor housing against soiling and intense heat from solar radiation.
<b>Flanges</b>	Screwed flanges are available in different versions according to the following standards: DIN 2501, EN 1092-1, BS 10, ASME B 16.5, JIS B 2210-1984, GOST 12821-80.

## 4 Mounting

### 4.1 General instructions

#### Process conditions



#### Note:

For safety reasons, the instrument must only be operated within the permissible process conditions. You can find detailed information on the process conditions in chapter "Technical data" of the operating instructions or on the type label.

Hence make sure before mounting that all parts of the instrument exposed to the process are suitable for the existing process conditions.

These are mainly:

- Active measuring component
- Process fitting
- Process seal

Process conditions in particular are:

- Process pressure
- Process temperature
- Chemical properties of the medium
- Abrasion and mechanical influences

#### Suitability for the ambient conditions

The instrument is suitable for standard and extended ambient conditions acc. to DIN/EN/IEC/ANSI/ISA/UL/CSA 61010-1. It can be used indoors as well as outdoors.

#### Installation position

Select an installation position you can easily reach for mounting and connecting as well as later retrofitting of a display and adjustment module. The housing can be rotated by 330° without the use of any tools. You can also install the display and adjustment module in four different positions (each displaced by 90°).

#### Moisture

Use the recommended cables (see chapter "Connecting to power supply") and tighten the cable gland.

You can give your instrument additional protection against moisture penetration by leading the connection cable downward in front of the cable gland. Rain and condensation water can thus drain off. This applies mainly to outdoor mounting as well as installation in areas where high humidity is expected (e.g. through cleaning processes) or on cooled or heated vessels.

To maintain the housing protection, make sure that the housing lid is closed during operation and locked, if necessary.

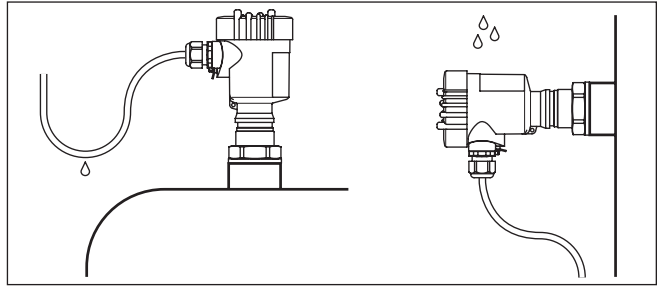

Fig. 2: Measures against moisture ingress

### Cable entries - NPT thread Cable glands

#### Metric threads

In the case of instrument housings with metric thread, the cable glands are screwed in at the factory. They are sealed with plastic plugs as transport protection.

You have to remove these plugs before electrical connection.

#### NPT thread

In the case of instrument housings with self-sealing NPT threads, it is not possible to have the cable entries screwed in at the factory. The free openings for the cable glands are therefore covered with red dust protection caps as transport protection.

Prior to setup you have to replace these protective caps with approved cable glands or close the openings with suitable blind plugs.

### Pressure/Vacuum

Gauge pressure in the vessel does not influence VEGASON 61. Low pressure or vacuum does, however, damp the ultrasonic pulses. This influences the measuring result, particularly if the level is very low. With pressures under -0.2 bar (-20 kPa) you should use a different measuring principle, e.g. radar or guided radar (TDR).

### Filter element

## 4.2 Housing features

The filter element in the housing is used for ventilation of the housing.

For effective ventilation, the filter element must always be free of deposits. Therefore, mount the device so that the filter element is protected against deposits.



#### Note:

Do not use a high-pressure cleaner to clean housings in standard types of protection. The filter element could be damaged and moisture could penetrate the housing.

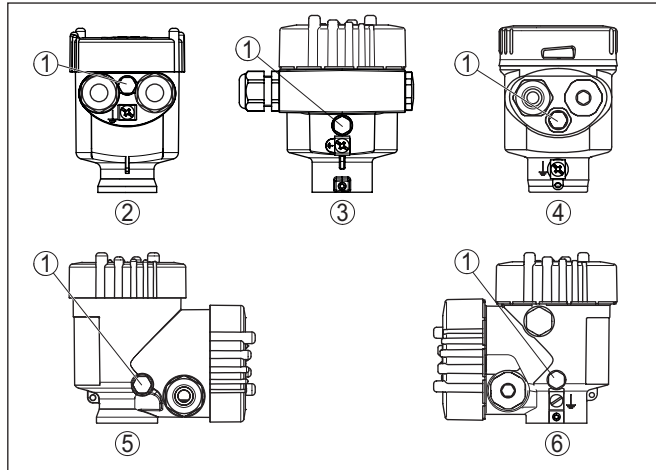

Fig. 3: Position of the filter element depending on housing

- 1 Filter element
- 2 Plastic single chamber
- 3 Aluminium single chamber, stainless steel single chamber (precision casting)
- 4 Stainless steel single chamber (electropolished)
- 5 Plastic double chamber
- 6 Aluminium - double chamber



**Information:**

For devices in protection class IP66/IP68 (1 bar), ventilation is provided by a capillary in the fixed cable. In these devices, a blind plug is installed in the housing instead of the filter element.

**Housing orientation**

The housing of VEGASON 61 can be rotated completely by 360°. This enables optimal reading of the display and easy cable entry.<sup>1)</sup>

For housings made of plastic or electropolished stainless steel, this is done without tools.

For housings made of aluminium or stainless steel (precision casting), a locking screw must be loosened for turning, see the following illustration:

<sup>1)</sup> No limitation by a rotation stop

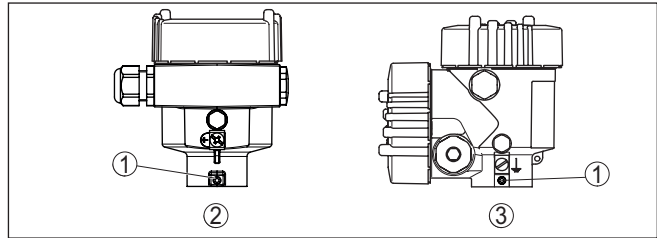

Fig. 4: Position of the locking screw depending on housing

- 1 Locking screw
- 2 Aluminium, stainless steel single chamber housing (precision casting)
- 3 Aluminium - double chamber

Proceed as follows:

1. Loosen locking screw (hexagon size 2.5)
2. Turn housing into requested position
3. Re-tighten the locking screw (torque see chapter "Technical data").

### Cover catch

With the aluminium and stainless steel housing (precision casting), the housing cover can be secured with a screw. This protects the device against unauthorised opening of the cover.

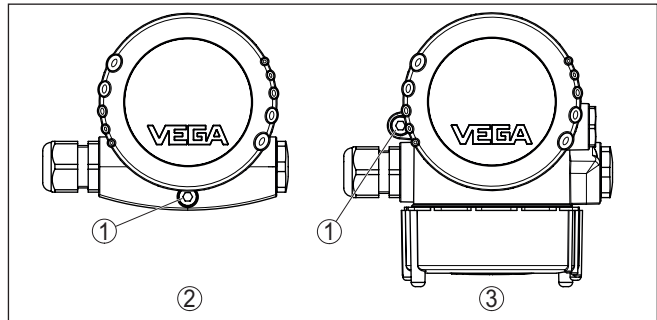

Fig. 5: Position of the safety screw depending on housing

- 1 Safety screw
- 2 Aluminium, stainless steel single chamber housing (precision casting)
- 3 Aluminium - double chamber

Proceed as follows to secure the cover:

1. Screw the housing cover on tightly by hand
2. Unscrew the locking screw from the cover up to the stop using a size 4 hexagonal spanner
3. Check if the cover can no longer be turned

The housing cover is unlocked in the opposite way.



#### Note:

The locking screw has two holes drilled through the head. Thus it can also be sealed.

### 4.3 Mounting instructions

#### Screwing in

Screw VEGASON 61 into the mounting socket with an appropriate spanner applied to the hexagon of the process fitting. Max. torque see chapter "Technical data".



#### Warning:

The housing must not be used to screw the instrument in! Applying tightening force can damage internal parts of the housing.

#### Installation position

When mounting the sensor, keep a distance of at least 200 mm (7.874 in) to the vessel wall. If the sensor is installed in the center of dished or round vessel tops, multiple echoes can arise. These can, however, be suppressed by an appropriate adjustment (see chapter "Setup").

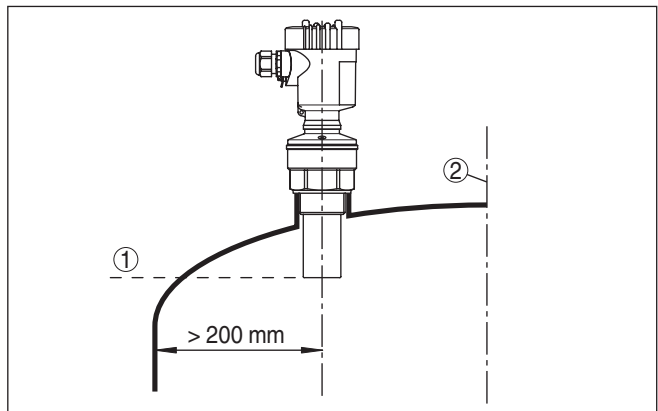

Fig. 6: Mounting on round vessel tops

- 1 Reference plane
- 2 Vessel center or symmetry axis

If this distance cannot be maintained, a false signal suppression should be carried out during setup. This applies particularly if buildup on the vessel wall is expected. In such cases, we recommend repeating the false signal suppression at a later date with existing buildup.

In vessels with conical bottom it can be advantageous to mount the device in the centre of the vessel, as measurement is then possible down to the bottom.

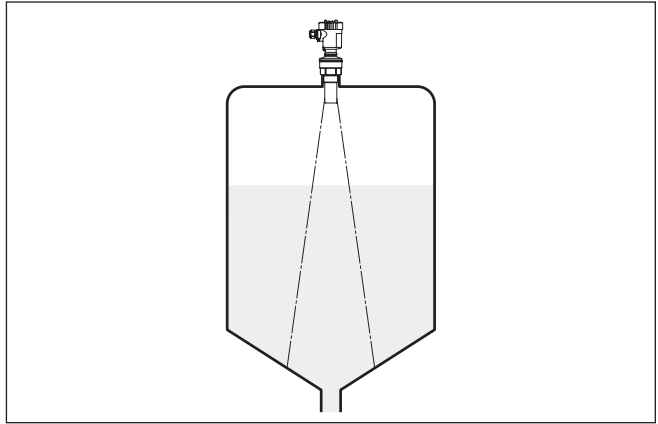

Fig. 7: Vessel with conical bottom

## Nozzle

Socket pieces should be dimensioned so that the lower end of the transducer protrudes at least 10 mm (0.394 in) out of the nozzle.

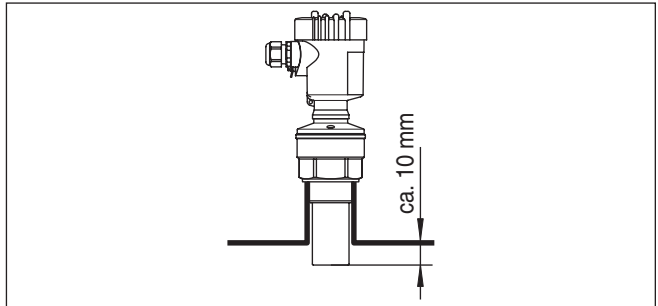

Fig. 8: Recommended socket mounting

If the reflective properties of the medium are good, you can mount VEGASON 61 on sockets which are higher than the length of the transducer. You will find recommended values for socket heights in the following illustration. The socket end should be smooth and burr-free, if possible also rounded. Carry out a false signal suppression.



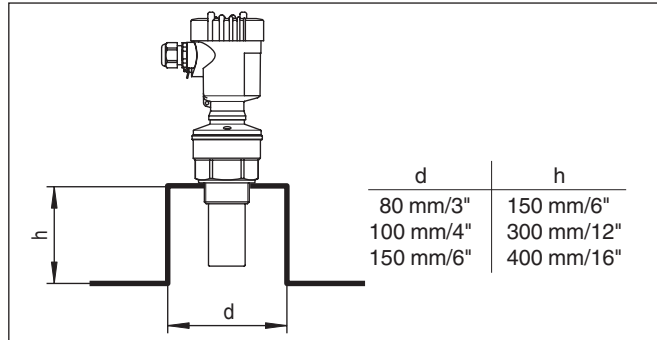

Fig. 9: Deviating socket dimensions

**Sensor orientation**

In liquids, direct the device as perpendicular as possible to the medium surface to achieve optimum measurement results.

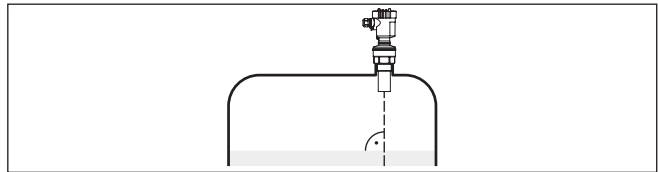

Fig. 10: Alignment in liquids

To reduce the blocking distance to the medium, you can also mount VEGASON 61 with a beam deflector. By doing this, it is possible to fill the vessel nearly to maximum. Such an arrangement is suitable primarily for open vessels such as e.g. overflow basins.

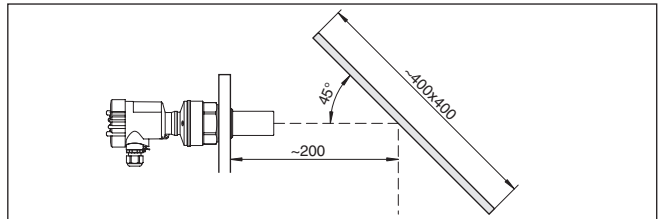

Fig. 11: Beam deflector

**Vessel installations**

The ultrasonic sensor should be installed at a location where no installations cross the ultrasonic beam.

Vessel installations such as for example, ladders, limit switches, heating spirals, struts etc. can cause false echoes that interfere with the useful echo. Make sure when planning your measuring site that the ultrasonic signals have a "clear view" to the measured product.

In case of existing vessel installations, a false signal suppression should be carried out during setup.

If large vessel installations such as struts or supports cause false echoes, these can be attenuated through supplementary measures. Small, inclined sheet metal or plastic baffles above the installations scatter the ultrasonic signals and avoid direct false echoes.

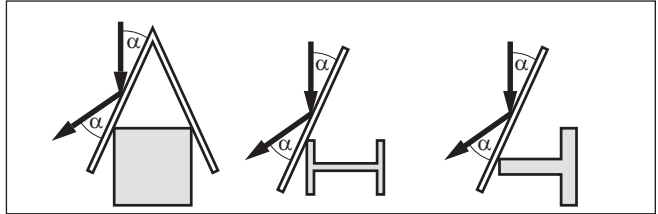

Fig. 12: Cover flat, large-area profiles with deflectors

### Agitators

If there are agitators in the vessel, a false signal suppression should be carried out with the agitators in motion. This ensures that the interfering reflections from the agitators are saved with the blades in different positions.

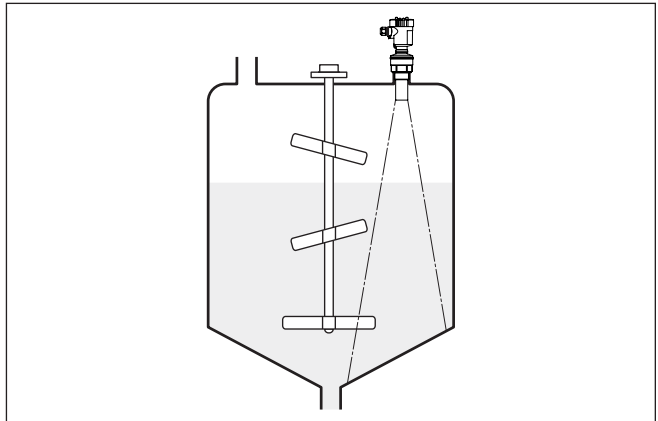

Fig. 13: Agitators

### Inflowing medium

Do not mount the instruments in or above the filling stream. Make sure that you detect the medium surface, not the inflowing product.

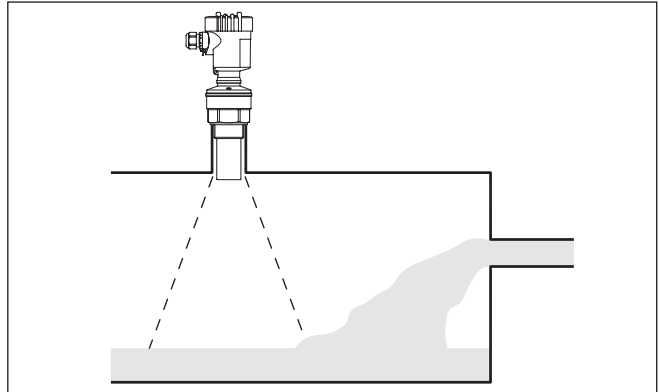

Fig. 14: Inflowing liquid

**Foam**

Through the action of filling, stirring and other processes in the vessel, dense foams which considerably damp the emitted signals may form on the medium surface.

If foams are causing measurement errors, the device should be used in a standpipe or, alternatively, the more suitable guided radar sensors (TDR) should be used.

Guided wave radar is unaffected by foam generation and is particularly suitable for such applications.

**Air turbulences**

If there are strong air currents in the vessel, e.g. due to strong winds in outdoor installations or air turbulence, e.g. by cyclone extraction you should mount VEGASON 61 in a standpipe or use a different measuring principle, e.g. radar or guided radar (TDR).

**Standpipe measurement**

By using a standpipe (surge or bypass tube), the influence of vessel installations, foam generation and turbulence is excluded.

Standpipes must extend all the way down to the requested min. level, as measurement is only possible within the tube.

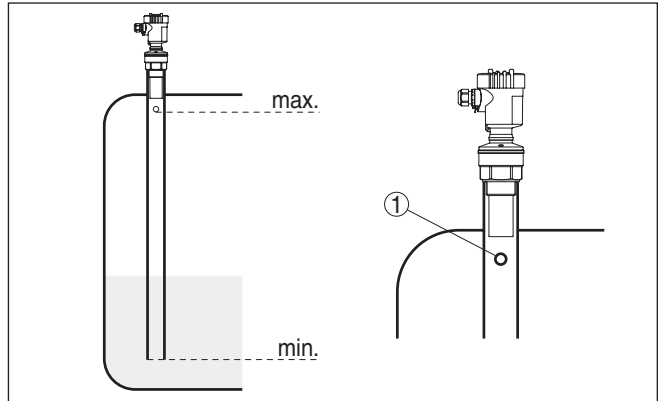

Fig. 15: Standpipe in the tank

1 Vent hole:  $\varnothing 5 \dots 10 \text{ mm}$  (0.197 ... 0.394 in)

VEGASON 61 can be used from tube diameters of 40 mm (1.575 in). Avoid large gaps and thick welding joints when connecting the tubes. Generally carry out a false signal suppression.

Measurement in a standpipe is not recommended for extremely adhesive products.

### Flow measurement with rectangular overflow

The short examples give you introductory information on flow measurement. Detailed planning information is available from flume manufacturers and in special literature.

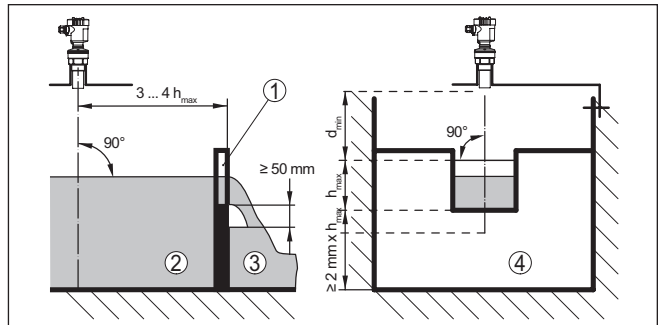

Fig. 16: Flow measurement with rectangular overflow:  $d_{\min}$  = blocking distance of the sensor (see chapter "Technical data");  $h_{\max}$  = max. filling of the rectangular spillway

- 1 Overflow orifice (side view)
- 2 Upstream water
- 3 Tailwater
- 4 Overflow orifice (view from tailwater)

In general, the following points must be observed:

- Install the sensor on the headwater side

- Installation in the centre of the flume and vertical to the liquid surface
- Distance to the overfall orifice
- Distance of orifice opening above ground
- Min. distance of the orifice opening to tailwater
- Distance of the sensor to the max. height of damming by taking the blocking distance into account

**Flow measurement with Khafagi Venturi flume**

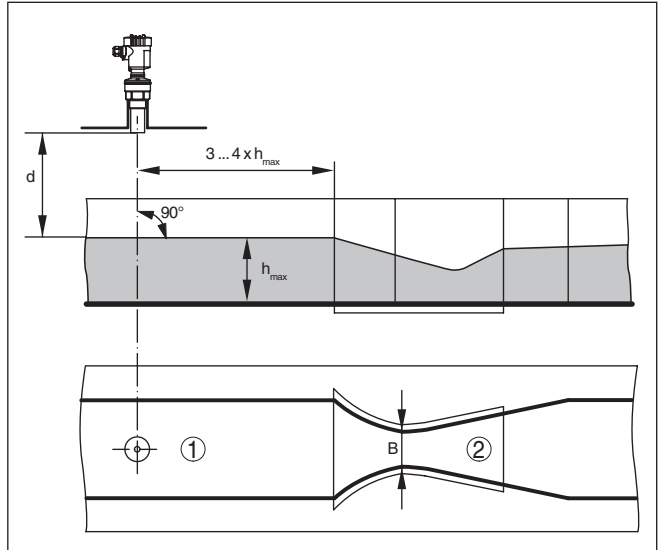

Fig. 17: Flow measurement with Khafagi-Venturi flume:  $d$  = Blocking distance to sensor;  $h_{max}$  = max. filling of the flume;  $B$  = tightest constriction in the flume

- 1 Position sensor
- 2 Venturi flume

In general, the following points must be observed:

- Installation of the sensor at the inlet side
- Installation in the centre of the flume and vertical to the liquid surface
- Distance to the Venturi flume
- Distance of the sensor to the max. height of damming by taking the blocking distance into account

## 5 Connecting to power supply

### 5.1 Preparing the connection

#### Safety instructions

Always keep in mind the following safety instructions:



#### Warning:

Connect only in the complete absence of line voltage.

- The electrical connection must only be carried out by trained, qualified personnel authorised by the plant operator.
- If overvoltage surges are expected, overvoltage arresters should be installed.

#### Voltage supply

Supply voltage and current output are carried on separate two-wire connection cables if reliable separation is required. The supply voltage range can differ depending on the instrument version.

The data for power supply are specified in chapter "*Technical data*".

The standard version can be operated with an earth-connected current output, the Ex d version must be operated with a floating output.

This instrument is designed in protection class I. To maintain this protection class, it is absolutely necessary that the ground conductor be connected to the internal ground terminal. Take note of the general installation regulations.

Always connect the instrument to vessel ground (potential equalisation) or in case of plastic vessels to the next ground potential. For this purpose there is a ground terminal on the side of the instrument housing.

#### Connection cable

For voltage supply, an approved installation cable with PE conductor is required.

The 4 ... 20 mA current output is connected with standard two-wire cable without shielding. If electromagnetic interference is expected which is above the test values of EN 61326 for industrial areas, shielded cable should be used.

Make sure that the cable used has the required temperature resistance and fire safety for max. occurring ambient temperature

Use cable with round cross section for instruments with housing and cable gland. To ensure the seal effect of the cable gland (IP protection rating), find out which cable outer diameter the cable gland is suitable for.

Use a cable gland fitting the cable diameter.

#### Cable screening and grounding

If shielded cable is required, we recommend connecting the cable screening on both ends to ground potential. In the sensor, the cable screening must be connected directly to the internal ground terminal. The ground terminal on the outside of the housing must be connected to the ground potential (low impedance).



In Ex systems, the grounding is carried out according to the installation regulations.

With the Exd version, the minus side of the signal output is galvanically connected to ground via protective diodes. When connecting the instrument to a grounded PLC, equalising currents can flow in case of potential differences which can cause malfunctions. Make sure that there is sufficient potential equalisation from the system side or realise the connection via switching amplifier.

## 5.2 Connection procedure

Proceed as follows:

1. Unscrew the housing lid
2. Loosen compression nut of the cable gland and remove blind plug
3. Remove approx. 10 cm (4 in) of the cable mantle (current output), strip approx. 1 cm (0.4 in) insulation from the ends of the individual wires
4. Insert the cable into the sensor through the cable entry
5. Lift the opening levers of the terminals with a screwdriver
6. Insert the wire ends into the open terminals according to the wiring plan

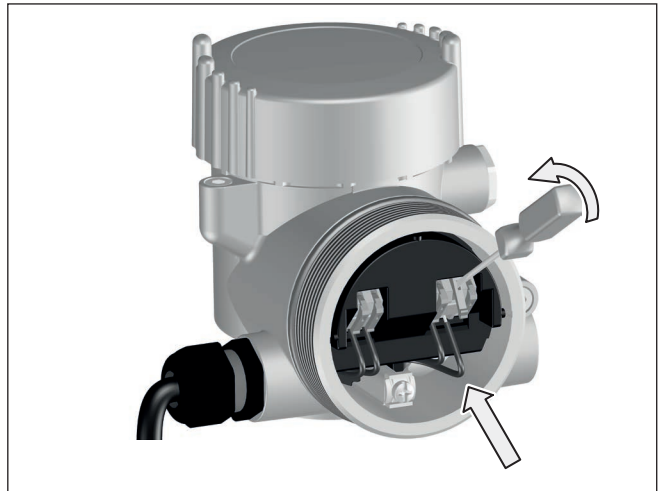

Fig. 18: Connection steps 5 and 6

7. Press down the opening levers of the terminals, you will hear the terminal spring closing
8. Check the hold of the wires in the terminals by lightly pulling on them
9. Connect the shielding to the internal ground terminal, connect the external ground terminal to potential equalisation
10. Tighten the compression nut of the cable entry gland. The seal ring must completely encircle the cable

11. Connect the lead cable for power supply in the same way according to the wiring plan, in addition connect the ground conductor to the inner ground terminal.
  12. Screw the housing lid back on
- The electrical connection is finished.

### 5.3 Wiring plan, double chamber housing

#### Housing overview

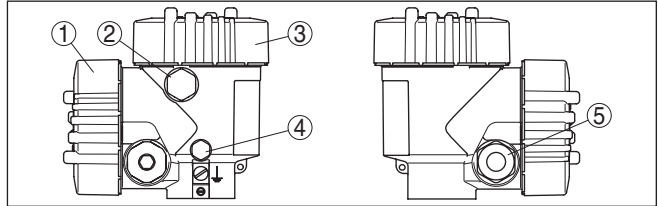

Fig. 19: Double chamber housing

- 1 Housing cover - connection compartment
- 2 Blind plug or M12 x 1 connection plug VEGADIS 81 (optional)
- 3 Housing cover - electronics compartment
- 4 Filter element for air pressure compensation
- 5 Cable gland

#### Electronics compartment

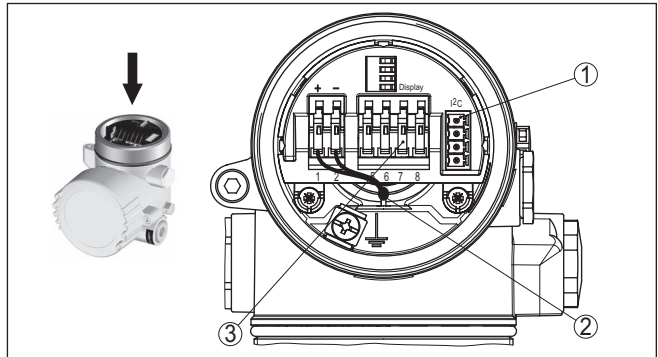

Fig. 20: Electronics compartment - double chamber housing

- 1 Plug connector for VEGACONNECT (I<sup>2</sup>C interface)
- 2 Internal connection cable to the connection compartment
- 3 Terminals for VEGADIS 81



Connection compartment

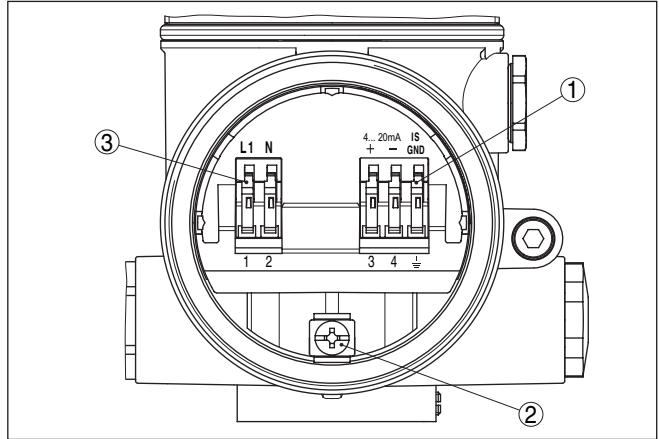

Fig. 21: Connection compartment - double chamber housing

- 1 Spring-loaded terminals for signal output
- 2 Ground terminal for connection of the ground conductor and screen
- 3 Spring-loaded terminals for voltage supply

Wiring plan

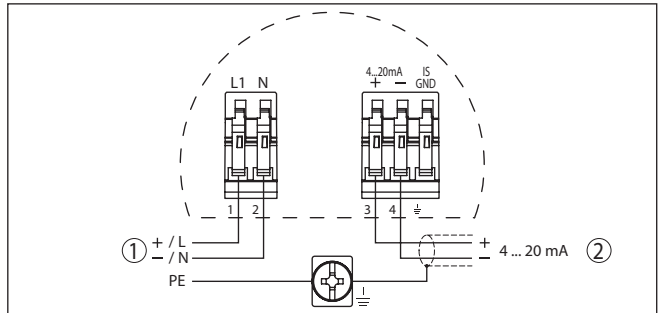

Fig. 22: Wiring plan - double chamber housing

- 1 Voltage supply
- 2 Signal output

5.4 Switch-on phase

Switch-on phase

After connecting VEGASON 61 to power supply or after a voltage recurrence, the instrument carries out a self-check for approx. 30 seconds:

- Internal check of the electronics
- Indication of the instrument type, the firmware as well as the sensor TAGs (sensor designation)
- Output signal jumps briefly (approx. 10 seconds) to the set fault current

Then the corresponding current is output to the cable (the value corresponds to the actual level as well as the settings already carried out, e.g. factory setting).

## 6 Set up with the display and adjustment module PLICSCOM

### 6.1 Insert display and adjustment module

#### Mount/dismount display and adjustment module

The display and adjustment module can be inserted into the sensor and removed again at any time. It is not necessary to interrupt the voltage supply.

Proceed as follows:

1. Unscrew the housing lid
2. Place the display and adjustment module in the desired position on the electronics (you can choose any one of four different positions - each displaced by 90°)
3. Press the display and adjustment module onto the electronics and turn it to the right until it snaps in
4. Screw housing lid with inspection window tightly back on

Disassembly is carried out in reverse order.

The display and adjustment module is powered by the sensor, an additional connection is not necessary.



Fig. 23: Insert display and adjustment module



#### Note:

If you intend to retrofit the instrument with a display and adjustment module for continuous measured value indication, a higher lid with an inspection glass is required.

## 6.2 Adjustment system

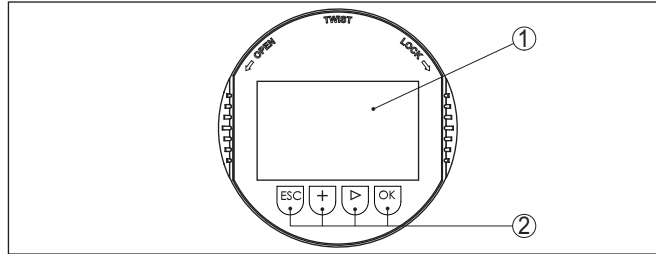

Fig. 24: Display and adjustment elements

- 1 LC display
- 2 Adjustment keys

### Key functions

- **[OK]** key:
  - Move to the menu overview
  - Confirm selected menu
  - Edit parameter
  - Save value
- **[>]** key:
  - Change measured value presentation
  - Select list entry
  - Select menu items in the quick setup menu
  - Select editing position
- **[+]** key:
  - Change value of the parameter
- **[ESC]** key:
  - Interrupt input
  - Jump to next higher menu

### Operating system - Keys direct

The instrument is operated via the four keys of the display and adjustment module. The individual menu items are shown on the LC display. You can find the function of the individual keys in the previous illustration.

### Time functions

When the **[+]** and **[>]** keys are pressed quickly, the edited value, or the cursor, changes one value or position at a time. If the key is pressed longer than 1 s, the value or position changes continuously.

When the **[OK]** and **[ESC]** keys are pressed simultaneously for more than 5 s, the display returns to the main menu. The menu language is then switched over to "English".

Approx. 60 minutes after the last pressing of a key, an automatic reset to measured value indication is triggered. Any values not confirmed with **[OK]** will not be saved.

## 6.3 Setup steps

### Address setting HART multidrop

In HART-Multidrop mode (several sensors on one input) the address must be set before continuing with the parameter adjustment. You

will find a detailed description in the operating instructions manual "Display and adjustment module" or in the online help of PACTware or DTM.

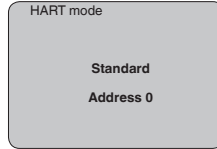

**Parameter adjustment**

The sensor measures the distance from the sensor to the medium surface. For indication of the real level, an allocation of the measured distance to the percentage height must be carried out.

The actual level is then calculated on the basis of these entered values. At the same time, the operating range of the sensor is limited from maximum range to the requested range.

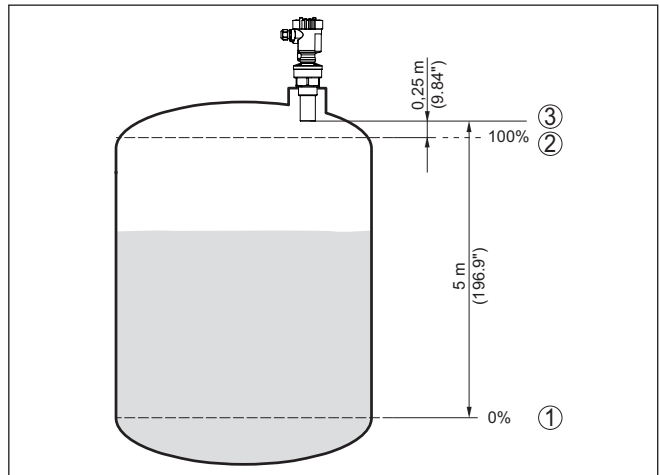

Fig. 25: Parameterisation example, Min./max. adjustment

- 1 Min. level = max. distance (depending on the sensor)
- 2 Max. level = min. distance (final value of the blocking distance, depending on the sensor)
- 3 Reference plane

The actual product level during this adjustment is not important, because the min./max. adjustment is always carried out without changing the product level. These settings can be made ahead of time without the instrument having to be installed.

**Basic adjustment - Min. adjustment**

Proceed as follows:

- 1. Move from the measured value display to the main menu by pushing [OK].

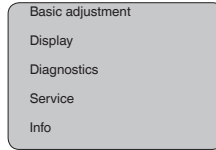

2. Select the menu item "*Basic adjustment*" with [->] and confirm with [OK]. Now the menu item "*Min. adjustment*" is displayed.

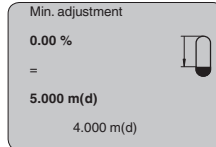

3. Prepare the % value for editing with [OK] and set the cursor to the requested position with [->]. Set the requested percentage value with [+] and save with [OK]. The cursor jumps now to the distance value.
4. Enter the distance value in m for empty vessel (e.g. distance from the sensor to the vessel bottom) corresponding to the percentage value.
5. Save the settings with [OK] and move to "Max. adjustment" with [->].

### Basic adjustment - Max. adjustment

Proceed as follows:

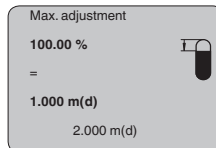

1. Prepare the % value for editing with [OK] and set the cursor to the requested position with [->]. Set the requested percentage value with [+] and save with [OK]. The cursor jumps now to the distance value.
2. Enter the appropriate distance value in m (corresponding to the percentage value) for the full vessel. Keep in mind that the max. level must lie below the blocking distance.
3. Save the settings with [OK] and move to "Medium selection" with [->].

### Basic adjustment - Medium

Each product has different reflective properties. In addition, there are various interfering factors which have to be taken into account: agitated product surfaces and foam generation (with liquids); dust generation, material cones and echoes from the vessel wall (with solids). To adapt the sensor to these different conditions, you should first select "*Liquid*" or "*Solid*".

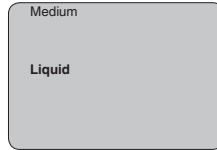

With solids, you can also choose between "Powder/Dust", "Granular/Pellets" or "Ballast/Pebbels".

Through this additional selection, the sensor is adapted perfectly to the product and measurement reliability, particularly in products with poor reflective properties, is considerably increased.

Enter the requested parameters via the appropriate keys, save your settings and jump to the next menu item with the [->] key.

**Basic adjustment - Vessel form**

Apart from the medium, the vessel shape can also influence the measurement. To adapt the sensor to these measuring conditions, this menu item offers different options depending on whether liquid or bulk solid is selected. With "Liquids" these are "Storage tank", "Stilling tube", "Open vessel" or "Stirred vessel", with "Solid", "Silo" or "Bunker".

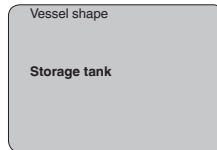

Enter the requested parameters via the appropriate keys, save your settings and jump to the next menu item with the [->] key.

**Basic adjustment - Damping**

To suppress fluctuations in the measured value display, e. g. caused by an agitated medium surface, a damping can be set. This time can be between 0 and 999 seconds. Keep in mind that the reaction time of the entire measurement will then be longer and the sensor will react to measured value changes with a delay. In general, a period of a few seconds is sufficient to smooth the measured value display.

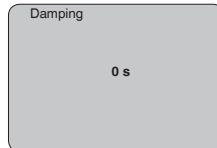

Enter the requested parameters via the appropriate keys, save your settings and jump to the next menu item with the [->] key.

**Basic adjustment - Linearization curve**

A linearisation is necessary for all vessels in which the vessel volume does not increase linearly with the level - e.g. in a horizontal cylindrical or spherical tank - and the indication or output of the volume is required. Corresponding linearisation curves are preprogrammed for these vessels. They represent the correlation between the level percentage and vessel volume. By activating the appropriate curve, the

volume percentage of the vessel is displayed correctly. If the volume should not be displayed in percent but e.g. in l or kg, a scaling can be also set in the menu item "*Display*".

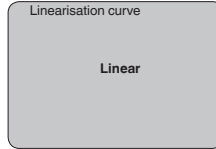

Enter the requested parameters via the appropriate keys, save your settings and jump to the next menu item with the **[->]** key.

### Basic adjustment - Sensor TAG

In this menu item you can enter an unambiguous designation for the sensor, e.g. the measurement loop name or the tank or product designation. In digital systems and in the documentation of larger plants, a singular designation should be entered for exact identification of individual measuring points.

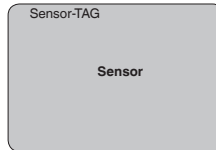

With this menu item, the Basic adjustment is finished and you can now jump to the main menu with the **[ESC]** key.

### Display - Indicated value

In the menu item "*Display*" you can define how the measured value should be presented on the display.

The following indication values are available:

- Height
- Distance
- Current
- Scaled
- Percent
- Lin. percent

The selection "*scaled*" opens the menu items "*Display unit*" and "*Scaling*". In "*Display unit*" there are the following options:

- Height
- Ground
- Flow
- Volume
- Without unit

Depending on selection, the different units are in turn available.

In the menu item "*Scaling*", the requested numerical value with decimal point is entered for 0 % and 100 % of the measured value.

There is the following relationship between the indication value in the menu "*Display*" and the adjustment unit in the menu "*Device settings*":



- Indication value "Distance": Presentation of the measured value in the selected adjustment unit, e.g. m(d).

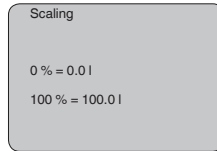
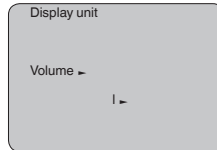
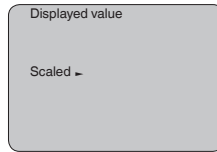

**Display - Backlight**

A background lighting integrated by default can be adjusted via the adjustment menu. The function depends on the height of the supply voltage. See "Technical data/Voltage supply".

To maintain the function of the device, the lighting is temporarily switched off if the power supply is insufficient.



In the default setting, the lightning is switched off.

**Diagnosis - Peak indicator**

The respective min. and max. measured values are saved in the sensor. The values are displayed in the menu item "Peak indicator".

- Min. and max. distance in m(d)
- Min. and max. temperature

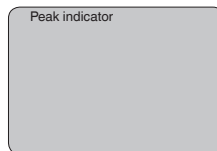

**Diagnosis - Measurement reliability**

When non-contact level sensors are used, the measurement can be influenced by the respective process conditions. In this menu item, the measurement reliability of the level echo is displayed as a dB value. Measurement reliability equals signal strength minus noise. The

higher the value, the more reliable the measurement. A well functioning measurement normally has a value > 10 dB.

### Diagnostics - Device status

The instrument status is displayed in this menu item. If no failure is detected by the sensor, "OK" will be displayed. If a failure is detected, there will be a sensor-specific flashing fault signal, for example "E013". The failure is also displayed in clear text, for example "No measured value available".



#### Information:

The fault message as well as the clear text indication are also carried out in the measured value display.

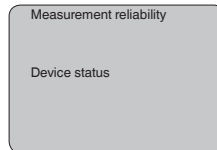

### Diagnosis - Curve selection

With ultrasonic sensors, the "Echo curve" represents the signal strength of the echoes over the measuring range. The unit of signal strength is "dB". The signal strength enables the judgement of the quality of the measurement.

The "False echo curve" displays the saved false echoes (see menu "Service") of the empty vessel as signal strength in "dB" over the measuring range.

Up to 3000 measured values are recorded (depending on the sensor) when starting a "Trend curve". Then the values can be displayed on a time axis. The oldest measured values are always deleted.

In the menu item "Choose curve", the respective curve is selected.

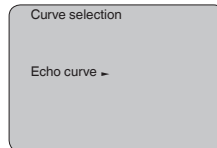

#### Information:

The trend recording is not activated when being shipped. It must be started by the user via the menu item "Start trend curve".

### Diagnosis - Curve presentation

A comparison of the echo curve and the false echo curve allows a more detailed evaluation of measurement reliability. The selected curve is updated continuously. With the [OK] key, a submenu with zoom functions is opened.

The following functions are available with "Echo and false echo curve":

- "X-Zoom": Zoom function for the meas. distance
- "Y-Zoom": 1, 2, 5 and 10x signal magnification in "dB"
- "Unzoom": Reset the presentation to the nominal measuring range without magnification

In the menu item "**Trend curve**" the following are available:

- "X-Zoom": Resolution
  - 1 minute
  - 1 hour
  - 1 day
- "Stop/Start": Interrupt a recording or start a new recording
- "Unzoom": Reset the resolution to minutes

As default setting, the recording pattern has 1 minute. With the adjustment software PACTware, this pattern can be also set to 1 hour or 1 day.

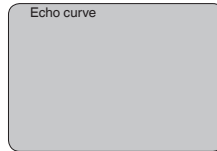

**Service - False signal suppression**

High nozzles or vessel installations, such as e. g. struts or agitators as well as buildup and weld joints on the vessel walls, cause interfering reflections which can impair the measurement. A false echo storage detects and marks these false echoes, so that they are no longer taken into account for the level measurement. A false echo memory should be created with low level so that all potential interfering reflections will be detected.

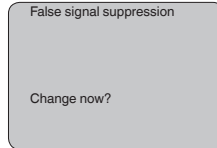

Proceed as follows:

1. Move from the measured value display to the main menu by pushing **[OK]**.
2. Select the menu item "*Service*" with **[->]** and confirm with **[OK]**. Now the menu item "*False signal suppression*" is displayed.
3. Confirm "*False signal suppression - Change now*" with **[OK]** and select in the below menu "*Create new*". Enter the actual distance from the sensor to the medium surface. All false signals in this area are detected by the sensor and saved after confirming with **[OK]**.



**Note:**

Check the distance to the medium surface, because if an incorrect (too large) value is entered, the existing level will be saved as a false signal. The level would then no longer be detectable in this area.

**Service - Extended setting**

The menu item "*Extended setting*" offers the possibility to optimise VEGASON 61 for applications in which the level changes very quickly. To do this, select the function "*Quick level change > 1 m/min.*".

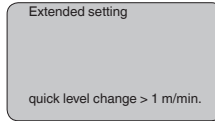
**Note:**

Since with the function "*Quick level change > 1 m/min.*" the generation of an average value of the signal processing is considerably reduced, false reflections by agitators or vessel installations can cause measured value fluctuations. A false signal suppression is thus recommended.

**Service - Current output**

In the menu item "*Current output*" you determine the behaviour of the current output during operation and in case of failure. The following options are available:

**Current output**

Characteristics	<b>4 ... 20 mA</b> 20 ... 4 mA
Failure mode <sup>2)</sup>	Hold value 20.5 mA 22 mA <b>&lt; 3.6 mA</b>
Min. current <sup>3)</sup>	<b>3.8 mA</b> 4 mA
Max. current <sup>4)</sup>	<b>20 mA</b> 20.5 mA

The values in bold font represent the data of the factory setting.

In HART multidrop mode, the current is constantly 4 mA. This value does not change even in case of failure.

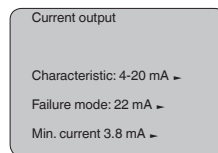
**Service - Simulation**

In this menu item you simulate a user-defined level or pressure value via the current output. This allows you to test the signal path, e.g. through connected indicating instruments or the input card of the control system.

The following simulation variables are available:

- Percent

<sup>2)</sup> Value of the current output in case of failure, e.g. if no valid measured value is delivered.

<sup>3)</sup> This value is not underrun during operation.

<sup>4)</sup> This value is not exceeded during operation.

- Current
- Pressure (with pressure transmitters)
- Distance (with radar and guided radar (GWR))

With Profibus PA sensors, the selection of the simulated value is made via the "Channel" in the menu "*Basic adjustments*".

How to start the simulation:

1. Push **[OK]**
2. Select the requested simulation variable with **[->]** and confirm with **[OK]**.
3. Set the requested numerical value with **[+]** and **[->]**.
4. Push **[OK]**

The simulation is now running, with 4 ... 20 mA/HART a current is output and with Profibus PA or Foundation Fieldbus a digital value.

How to interrupt the simulation:

→ Push **[ESC]**



**Information:**

The simulation is automatically terminated 10 minutes after the last pressing of a key.

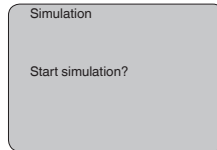

**Service - Reset**

If the function "*Reset*" is carried out, the sensor resets the values of the following menu items to the reset values (see table):<sup>5)</sup>

Function	Reset value
Max. adjustment	Final value blocking distance in m(d) <sup>6)</sup>
Min. adjustment	Meas. range end in m(d) <sup>7)</sup>
Medium	Liquid
Vessel shape	not known
Damping	0 s
Linearisation	Linear
Sensor-TAG	Sensor
Displayed value	Distance
Current output - characteristics	4 ... 20 mA
Current output - max. current	20.5 mA
Current output - min. current	3.8 mA
Current output - failure	< 3.6 mA

<sup>5)</sup> Sensor-specific basic adjustment.

<sup>6)</sup> Depending on the sensor type, see chapter "Technical data".

<sup>7)</sup> Depending on the sensor type, see chapter "Technical data".

Function	Reset value
Unit of measurement	m(d)

The values of the following menu items are *not* reset to the reset values (see table) with "**Reset**":

Function	Reset value
Backlight	No reset
Language	No reset
HART mode	No reset

### Default setting

Like basic adjustment, but in addition, special parameters are reset to default values.<sup>9)</sup>

### Peak indicator

The min. and max. distance and temperature values are reset to the actual value.

**Service - Adjustment unit** In this menu item you select the internal arithmetic unit of the sensor.

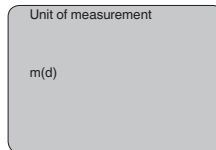

### Service - Language

The sensor is already set to the ordered national language. In this menu item you can change the language. The following languages are available as of software version 3.50:

- Deutsch
- English
- Français
- Español
- Pycckuu
- Italiano
- Netherlands
- Japanese
- Chinese

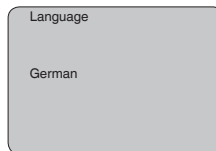

### Service - SIL

The functional safety is already activated Ex factory for instruments with SIL qualification. For instruments Ex factory without SIL qualifica-

<sup>9)</sup> Special parameters are parameters which are set customer-specifically on the service level with the adjustment software PACTware.

tion, the functional safety must be activated by the user for applications according to SIL via the indicating and adjustment module. The SIL factory setting cannot be deactivated by the user.

The activation of SIL has the following impact:

- In the menu item "*Failure mode*" under "*Current output*", the parameters "*Hold value*" and "*20.5 mA*" are blocked
- In the menu item "*HART mode*", the function "*Multidrop*" is blocked



**Note:**

For such applications, it is absolutely necessary to take note of "*Safety Manual*".

**Service - HART mode**

HART offers standard and multidrop mode.

The mode "standard" with the fixed address 0 means outputting the measured value as a 4 ... 20 mA signal.

In Multidrop mode, up to 15 sensors can be operated on one two-wire cable. An address between 1 and 15 must be assigned to each sensor.<sup>9)</sup>

In this menu item you determine the HART mode and enter the address for multidrop.

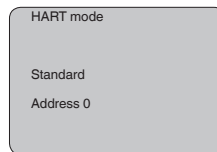

The default setting is standard with address 0.

**Service - Copy sensor data**

This function enables reading out parameter adjustment data as well as writing parameter adjustment data into the sensor via the display and adjustment module. A description of the function is available in the operating instructions manual "*Display and adjustment module*".

The following data are read out or written with this function:

- Measured value presentation
- Adjustment
- Medium
- Vessel shape
- Damping
- Linearisation curve
- Sensor-TAG
- Displayed value
- Display unit
- Scaling
- Current output
- Unit of measurement
- Language

<sup>9)</sup> The 4 ... 20 mA signal of the sensor is switched off. The sensor uses a constant current of 4 mA. The measuring signal is transmitted exclusively as a digital HART signal.

The following safety-relevant data are **not** read out or written:

- HART mode
- PIN

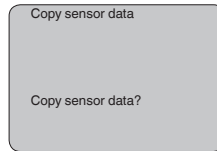

### Service - PIN

In this menu item, the PIN is activated/deactivated permanently. Entering a 4-digit PIN protects the sensor data against unauthorized access and unintentional modifications. If the PIN is activated permanently, it can be deactivated temporarily (i.e. for approx. 60 min.) in any menu item. The instrument is delivered with the PIN set to 0000.

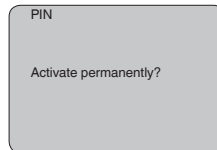

Only the following functions are permitted with activated PIN:

- Select menu items and show data
- Read data from the sensor into the display and adjustment module

### Info

In this menu item the most important sensor information can be displayed:

- Instrument type
- Serial number: 8-digit number, e.g. 12345678

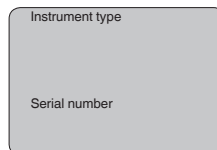

- Date of manufacture: Date of the factory calibration
- Software version: Edition of the sensor software

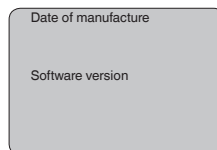

- Date of last change using PC: Date of the last change of sensor parameters via PC



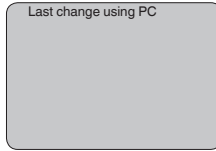

- Sensor details, e.g. approval, process fitting, seal, measuring cell, measuring range, electronics, housing, cable entry, plug, cable length etc.

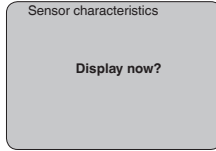

## 6.4 Menu schematic



### Information:

Depending on the version and application, the highlighted menu windows may not always be available.

### Basic adjustment

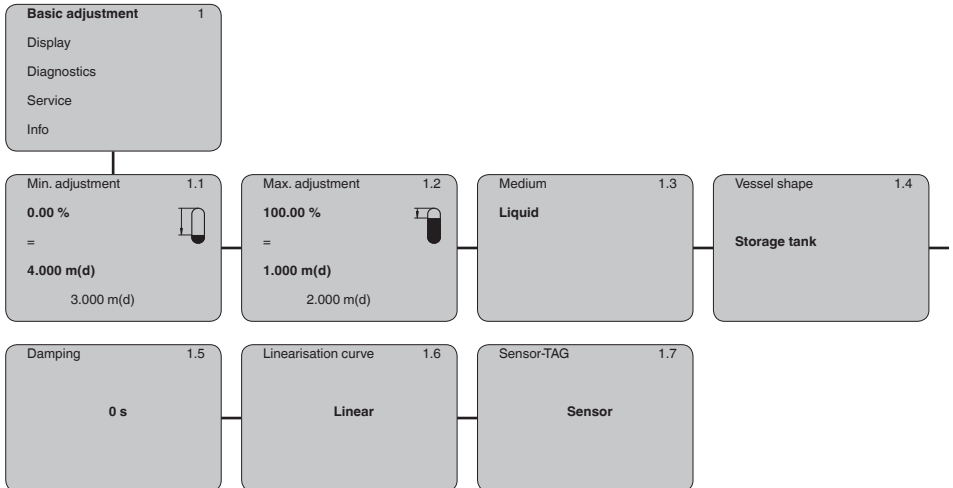

**Display**

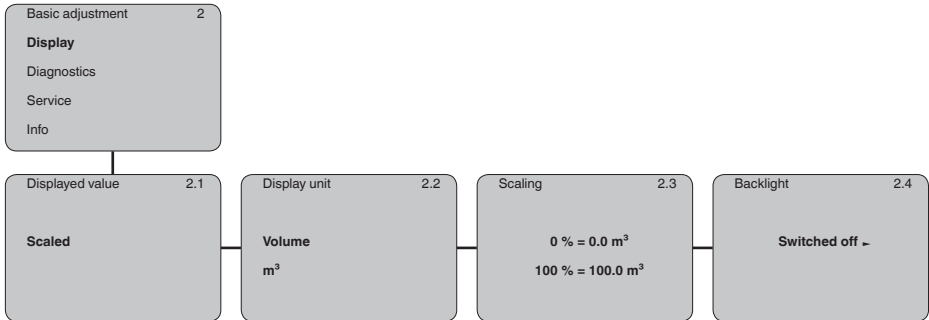

**Diagnostics**

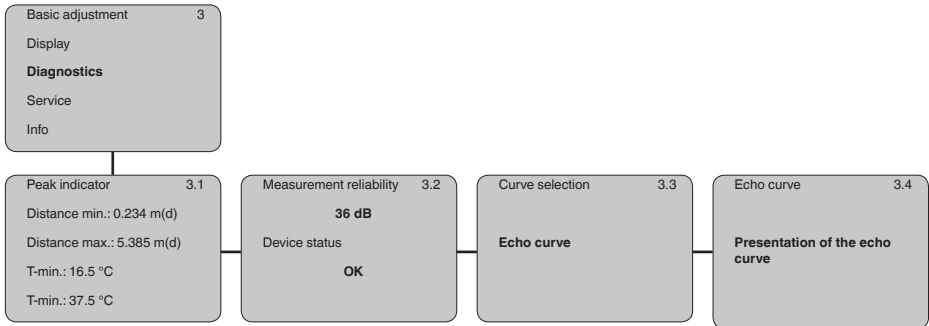

**Service**

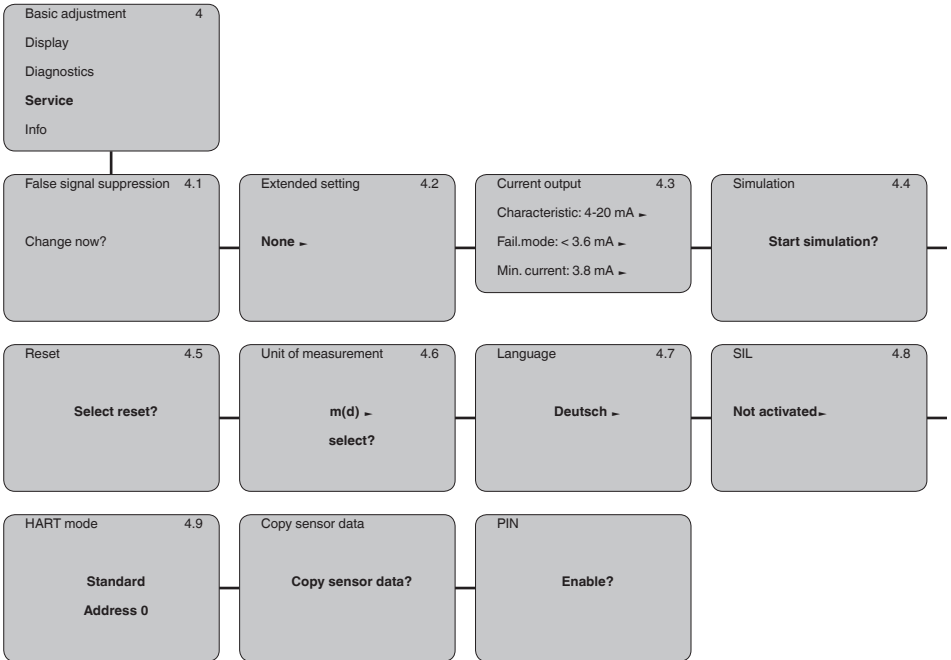

**Info**

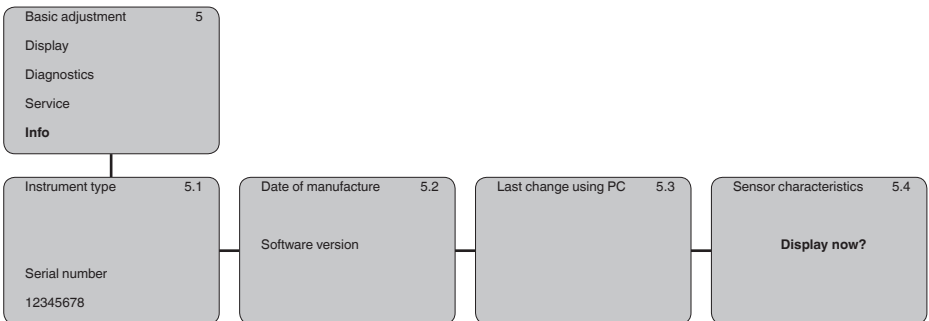

**6.5 Saving the parameterisation data**

We recommended writing down the adjustment data, e.g. in this operating instructions manual, and archiving them afterwards. They are thus available for multiple use or service purposes.

**On paper**

**In the display and adjustment module**

If the instrument is equipped with a display and adjustment module, the parameter adjustment data can be saved in it. The data remain

permanently stored there even if the sensor supply fails. The procedure is described in menu item "*Copy sensor data*".

## 7 Setup with PACTware

### 7.1 Connect the PC via VEGACONNECT

Via the interface adapter directly on the sensor

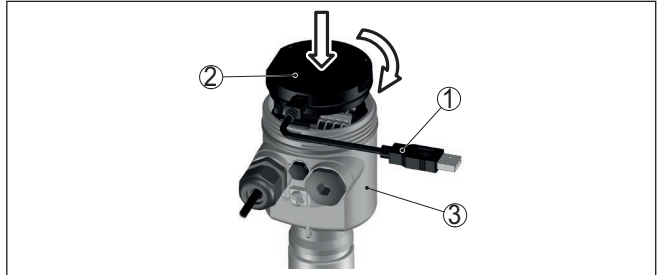

Fig. 26: Connection of the PC directly to the sensor via the interface adapter

- 1 USB cable to the PC
- 2 Interface adapter VEGACONNECT
- 3 Sensor

Via interface adapter external

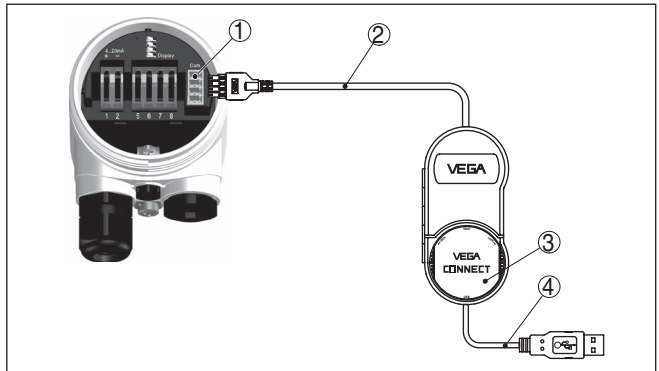

Fig. 27: Connection via interface adapter VEGACONNECT external

- 1 I<sup>2</sup>C bus (com.) interface on the sensor
- 2 I<sup>2</sup>C connection cable of VEGACONNECT
- 3 Interface adapter VEGACONNECT
- 4 USB cable to the PC

## Via the interface adapter and HART

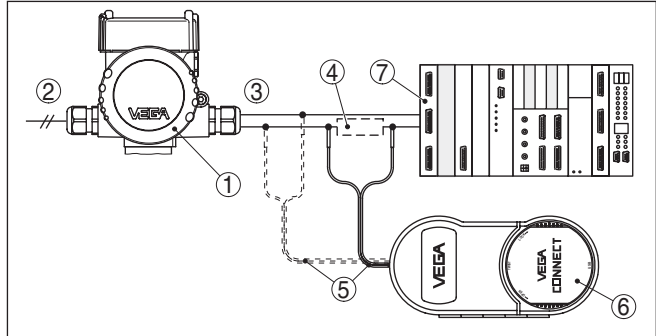

Fig. 28: Connecting the PC via HART to the signal cable

- 1 VEGASON 61
- 2 Voltage supply
- 3 4 ... 20 mA signal output
- 4 HART resistance approx. 250  $\Omega$  (optional depending on processing)
- 5 Connection cable with 2 mm pins and terminals
- 6 VEGACONNECT
- 7 Processing system/PLC



### Note:

With power supply units with integrated HART resistance (internal resistance approx. 250  $\Omega$ ), an additional external resistance is not necessary. This applies, e.g. to the VEGA instruments VEGATRENN 149A, VEGAMET 381 and VEGAMET 391). Commercially available Ex separators are also usually equipped with sufficient current limitation resistance. In such cases, VEGACONNECT can be connected parallel to the 4 ... 20 mA cable.

## 7.2 Parameter adjustment

### Prerequisites

For parameter adjustment of the instrument via a Windows PC, the configuration software PACTware and a suitable instrument driver (DTM) according to FDT standard are required. The latest PACTware version as well as all available DTMs are compiled in a DTM Collection. The DTMs can also be integrated into other frame applications according to FDT standard.



### Note:

To ensure that all instrument functions are supported, you should always use the latest DTM Collection. Furthermore, not all described functions are included in older firmware versions. You can download the latest instrument software from our homepage. A description of the update procedure is also available in the Internet.

Further setup steps are described in the operating instructions manual "DTM Collection/PACTware" attached to each DTM Collection and which can also be downloaded from the Internet. Detailed descriptions are available in the online help of PACTware and the DTMs.

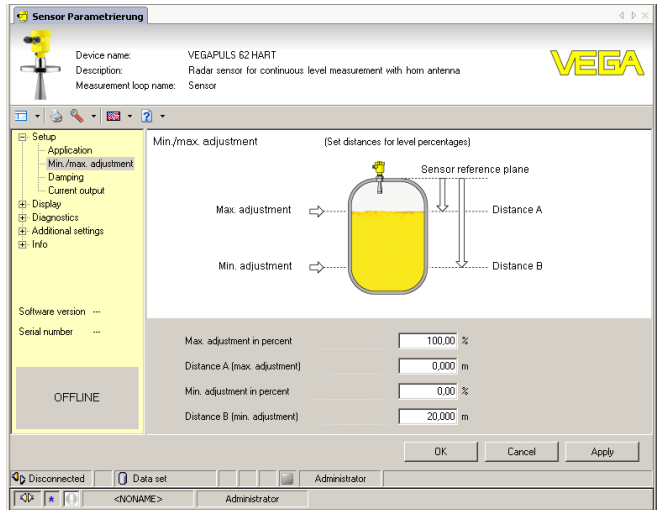

Fig. 29: Example of a DTM view

### 7.3 Save parameter adjustment data

We recommend documenting or saving the parameterisation data via PACTware. That way the data are available for multiple use or service purposes.

## **8 Set up with other systems**

### **8.1 DD adjustment programs**

Device descriptions as Enhanced Device Description (EDD) are available for DD adjustment programs such as, for example, AMS™ and PDM.

The files can be downloaded at [www.vega.com/downloads](http://www.vega.com/downloads) under "*Software*".



## 9 Maintenance and fault rectification

### 9.1 Maintenance

**Maintenance**

If the device is used properly, no special maintenance is required in normal operation.

**Cleaning**

The cleaning helps that the type label and markings on the instrument are visible.

Take note of the following:

- Use only cleaning agents which do not corrode the housings, type label and seals
- Use only cleaning methods corresponding to the housing protection rating

### 9.2 Rectify faults

**Reaction when malfunction occurs**

The operator of the system is responsible for taking suitable measures to rectify faults.

**Causes of malfunction**

The device offers maximum reliability. Nevertheless, faults can occur during operation. These may be caused by the following, e.g.:

- Sensor
- Process
- Voltage supply
- Signal processing

**Fault rectification**

The first measures are:

- Evaluation of fault messages
- Checking the output signal
- Treatment of measurement errors

A smartphone/tablet with the adjustment app or a PC/notebook with the software PACTware and the suitable DTM offer you further comprehensive diagnostic possibilities. In many cases, the causes can be determined in this way and the faults eliminated.

**4 ... 20 mA signal**

Connect a multimeter in the suitable measuring range according to the wiring plan. The following table describes possible errors in the current signal and helps to eliminate them:

Error	Cause	Rectification
4 ... 20 mA signal not stable	Fluctuating measured value	Set damping
4 ... 20 mA signal missing	Electrical connection faulty	Check connection, correct, if necessary
	Voltage supply missing	Check cables for breaks; repair if necessary
	Operating voltage too low, load resistance too high	Check, adapt if necessary
Current signal greater than 22 mA, less than 3.6 mA	Sensor electronics defective	Replace device or send in for repair depending on device version

28778-EN-231026

### Error messages via the display and adjustment module

Error	Cause	Rectification
E013	no measured value available	Sensor in boot phase Sensor does not find an echo, e.g. due to faulty installation or wrong parameter adjustment
E017	Adjustment span too small	Carry out a fresh adjustment and increase the distance between min. and max. adjustment
E036	no operable sensor software	Carry out a software update or send instrument for repair
E041	Hardware error, electronics defective	Exchange the instrument or send it in for repair

### Reaction after fault rectification

Depending on the reason for the fault and the measures taken, the steps described in chapter "Setup" must be carried out again or must be checked for plausibility and completeness.

### 24 hour service hotline

Should these measures not be successful, please call in urgent cases the VEGA service hotline under the phone no. **+49 1805 858550**.

The hotline is also available outside normal working hours, seven days a week around the clock.

Since we offer this service worldwide, the support is provided in English. The service itself is free of charge, the only costs involved are the normal call charges.

## 9.3 Exchanging the electronics module

If the electronics module is defective, it can be replaced by the user.



In Ex applications, only instruments and electronics modules with appropriate Ex approval may be used.

If there is no electronics module available on site, one can be ordered from the VEGA agency serving you.

### Sensor serial number

The new electronics module must be loaded with the settings of the sensor. These are the options:

- At the factory by VEGA
- Or on site by the user

In both cases, the sensor serial number is necessary. The serial numbers are stated on the type label of the instrument, inside the housing or on the delivery note.



#### Information:

When loading on site, the order data must first be downloaded from the Internet (see operating instructions "Electronics module").

### Assignment

The electronics modules are adapted to the respective sensor and distinguish also in the signal output or power supply.

## 9.4 Software update

The following components are required to update the instrument software:

- Instrument
- Voltage supply
- Interface adapter VEGACONNECT
- PC with PACTware
- Current instrument software as file

You can find the current instrument software as well as detailed information on the procedure in the download area of our homepage: [www.vega.com](http://www.vega.com).

You can find information about the installation in the download file.



### Caution:

Instruments with approvals can be bound to certain software versions. Therefore make sure that the approval is still effective after a software update is carried out.

You can find detailed information in the download area at [www.vega.com](http://www.vega.com).

## 9.5 How to proceed if a repair is necessary

On our homepage you will find detailed information on how to proceed in the event of a repair.

So that we can carry out the repair quickly and without queries, generate a instrument return form there with the data of your device.

You will need:

- The serial number of the instrument
- A short description of the problem
- Details of the medium

Print the generated instrument return form.

Clean the instrument and pack it damage-proof.

Send the printed instrument return form and possibly a safety data sheet together with the device.

You will find the address for the return on the generated instrument return form.

## 10 Dismount

### 10.1 Dismounting steps

**Warning:**

Before dismantling, be aware of dangerous process conditions such as e.g. pressure in the vessel or pipeline, high temperatures, corrosive or toxic media etc.

Take note of chapters "*Mounting*" and "*Connecting to voltage supply*" and carry out the listed steps in reverse order.

### 10.2 Disposal



Pass the instrument on to a specialised recycling company and do not use the municipal collecting points.

Remove any batteries in advance, if they can be removed from the device, and dispose of them separately.

If personal data is stored on the old device to be disposed of, delete it before disposal.

If you have no way to dispose of the old instrument properly, please contact us concerning return and disposal.

## 11 Supplement

### 11.1 Technical data

#### Note for approved instruments

The technical data in the respective safety instructions which are included in delivery are valid for approved instruments (e.g. with Ex approval). These data can differ from the data listed herein, for example regarding the process conditions or the voltage supply.

All approval documents can be downloaded from our homepage.

#### General data

##### Materials, wetted parts

- |  |           |
|--|-----------|
| – Transducer                           | PVDF      |
| – Seal transducer/process fitting      | EPDM, FKM |
| – Process fitting G1½, DIN 3852-A-B    | PVDF      |
| – Process fitting 1½ NPT, ASME B1.20.1 | PVDF      |

##### Materials, non-wetted parts

- |                                   |   |
|-----------------------------------|---|
| – Housing                         | Plastic PBT (polyester), Alu die-casting, powder-coated, 316L |
| – Seal, housing lid               | Silicone SI 850 R   |
| – Inspection window housing cover | Polycarbonate (UL-746-C listed), glass <sup>10</sup>          |
| – Ground terminal                 | 316Ti/316L  |
| – Cable gland                     | PA, stainless steel, brass                                    |
| – Sealing, cable gland            | NBR   |
| – Blind plug, cable gland         | PA  |

Weight	1.8 ... 4 kg (4 ... 8.8 lbs), depending on the process fitting and housing
--------	--

Max. torque mounting boss	25 Nm (18.44 lbf ft)
---------------------------	----------------------

#### Input variable

Measured variable	distance between lower edge of the transducer and medium surface
-------------------	--

##### Measuring range

- |               |                      |
|---------------|----------------------|
| – Liquids     | up to 5 m (16.4 ft)  |
| – Bulk solids | up to 2 m (6.562 ft) |

blocking distance	0.25 m (0.82 ft)
-------------------	------------------

#### Output variable

Output signal	4 ... 20 mA/HART (active)
---------------	---------------------------

##### HART output values

- |                                |                       |
|--------------------------------|-----------------------|
| – HART value (Primary Value)   | Distance to the level |
| – HART value (Secondary Value) | Temperature           |

<sup>10)</sup> Glass (with Aluminium and stainless steel precision casting housing)

– HART value (3rd Value)	Distance to the level - scaled
Resolution	1.6 $\mu\text{A}$
Fault signal, current output (adjustable)	mA-value unchanged 20.5 mA, 22 mA, < 3.6 mA
Current limitation	22 mA
Load	< 500 $\Omega^{11)}$
Damping (63 % of the input variable)	0 ... 999 s, adjustable
Met NAMUR recommendation	NE 43

### Deviation

Deviation <sup>12)</sup>	$\leq 4 \text{ mm}$ (meas. distance $\leq 2.0 \text{ m}/6.562 \text{ ft}$ )
--------------------------	---

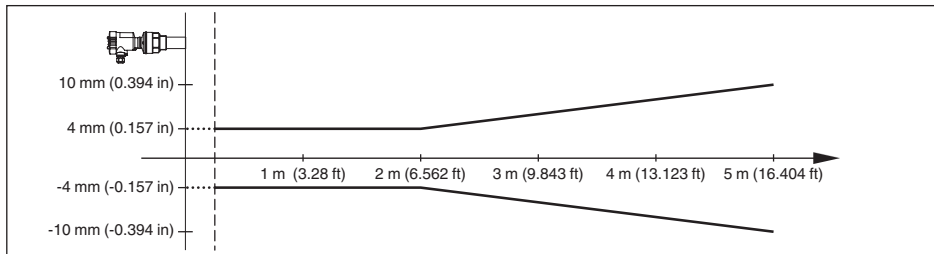

Fig. 30: Deviation VEGASON 61

### Reference conditions to measurement accuracy (according to DIN EN 60770-1)

Reference conditions according to DIN EN 61298-1

– Temperature	+18 ... +30 $^{\circ}\text{C}$ (+64 ... +86 $^{\circ}\text{F}$ )
– Relative humidity	45 ... 75 %
– Air pressure	860 ... 1060 mbar/86 ... 106 kPa (12.5 ... 15.4 psig)

Other reference conditions

– Reflector	ideal reflector, e.g. metal plate 2 x 2 m (6.56 x 6.56 ft)
– False reflections	Biggest false signal, 20 dB smaller than the useful signal

### Measuring characteristics

Ultrasonic frequency	70 kHz
Interval	> 2 s (dependent on the parameter adjustment)
Abstrahlwinkel at -3 dB	11 $^{\circ}$
Step response or adjustment time <sup>13)</sup>	> 3 s (dependent on the parameter adjustment)

### Influence of the ambient temperature to the sensor electronics<sup>14)</sup>

Average temperature coefficient of the zero signal (temperature error)	0.06 %/10 K
--	-------------

<sup>11)</sup> With inductive load ohmic share min. 25  $\Omega/\text{mH}$ .

<sup>12)</sup> Incl. non-linearity, hysteresis and non-repeatability.

<sup>13)</sup> Time to output the correct level (with max. 10 % deviation) after a sudden level change.

<sup>14)</sup> Relating to the nominal measuring range.

## Ambient conditions

Ambient, storage and transport temperature -40 ... +70 °C (-40 ... +158 °F)

## Process conditions

Process pressure -20 ... 200 kPa/-0.2 ... 2 bar (-2.9 ... 29 psig)

Process temperature (transducer temperature)

- Seal EPDM -40 ... +80 °C (-40 ... +176 °F)
- Seal FKM -20 ... +80 °C (-4 ... +176 °F)

Vibration resistance mechanical vibrations with 4 g and 5 ... 100 Hz<sup>15)</sup>

## Electromechanical data - version IP66/IP67

### Cable entry

- Double chamber housing
  - 1 x cable gland M20 x 1.5 (cable: ø 5 ... 9 mm), 1 x blind plug M20 x 1.5; plug M12 x 1 for VEGADIS 61 (optional)
  - or:
  - 1 x closing cap ½ NPT, 1 x blind plug ½ NPT, plug M12 x 1 for VEGADIS 61 (optional)
  - or:
  - 1 x plug (depending on the version), 1 x blind plug M20 x 1.5; plug M12 x 1 for VEGADIS 61 (optional)

Spring-loaded terminals for wire cross-section < 2.5 mm<sup>2</sup> (AWG 14)

## Display and adjustment module

Display element	Display with backlight
Measured value indication	
- Number of digits	5
Adjustment elements	
- 4 keys	<b>[OK], [-&gt;], [+], [ESC]</b>
- Switch	Bluetooth On/Off
Bluetooth interface	
- Standard	Bluetooth LE
- Effective range	25 m (82.02 ft)
Protection rating	
- unassembled	IP20
- Mounted in the housing without lid	IP40
Materials	
- Housing	ABS
- Inspection window	Polyester foil
Functional safety	SIL non-reactive

<sup>15)</sup> Tested according to the guidelines of German Lloyd, GL directive 2.

---

**Voltage supply**

---

Operating voltage

- Non-Ex and Ex d instrument 20 ... 72 V DC, 20 ... 253 V AC, 50/60 Hz

Power consumption

max. 4 VA; 2.1 W

---

**Electrical protective measures**

---

Protection rating

IP66/IP67 (NEMA Type 4X)

Overvoltage category (IEC 61010-1)

- up to 2000 m (6562 ft) above sea level III
- up to 5000 m (16404 ft) above sea level III - Only with connected overvoltage protection
- up to 5000 m (16404 ft) above sea level II

Pollution degree<sup>16)</sup>

4

Protection rating (IEC 61010-1)

I

---

**Functional safety (SIL)**

---

Functional safety is already activated on instruments with SIL qualification ex factory. On instruments without SIL qualification ex factory, the functional safety must be activated by the user via the display and adjustment module or via PACTware for applications according to SIL.

Functional safety according to IEC 61508-4

- Single channel architecture (1oo1D) up to SIL2
- double channel diversitary redundant architecture (1oo2D) up to SIL3

You can find detailed information in the supplied Safety Manual of the instrument series or under "[www.vega.com](http://www.vega.com)", "Downloads", "Approvals".

---

**Approvals**

---

Instruments with approvals can have different technical specifications depending on the version.

For that reason the associated approval documents of these instruments have to be carefully noted. They are part of the delivery or can be downloaded by entering the serial number of your instrument into the search field under [www.vega.com](http://www.vega.com) as well as in the general download area.

## 11.2 Dimensions

The listed drawings represent only an excerpt of the available process fittings. You can find more drawings at [www.vega.com](http://www.vega.com) via the configurator of VEGASON 61.

<sup>16)</sup> When used with fulfilled housing protection



Housing

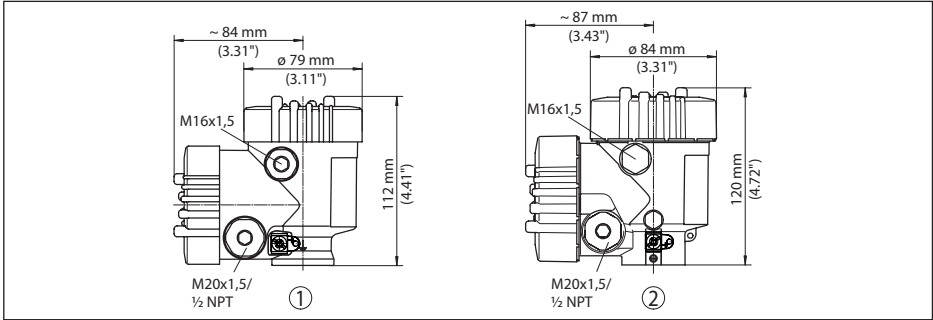

Fig. 31: Housing versions in protection rating IP66/IP67 and IP66/IP68 (0.2 bar), (with integrated display and adjustment module the housing is 9 mm/0.35 in or by 18 mm/0.71 in higher)

- 1 Plastic double chamber
- 2 Aluminium - double chamber

VEGASON 61

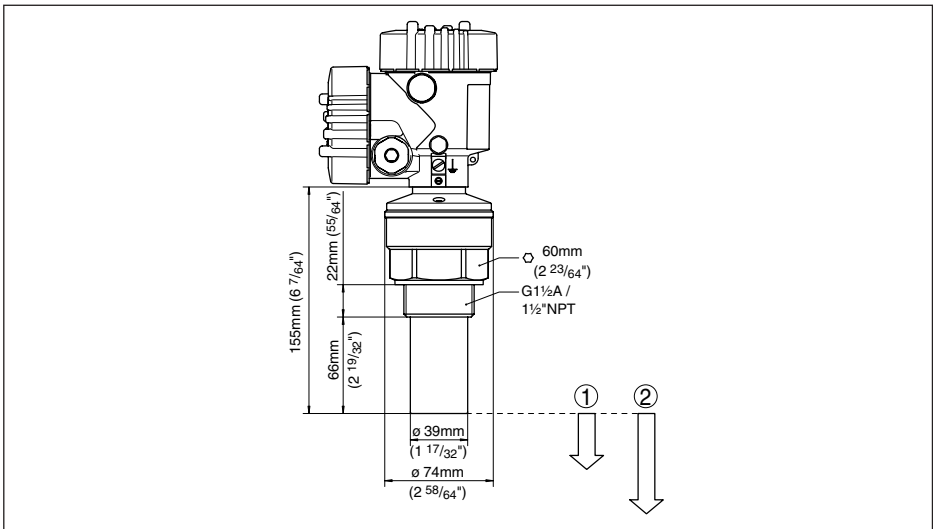

Fig. 32: VEGASON 61

- 1 Dead zone: 0.25 m (0.82 ft)
- 2 Measuring range: with liquids up to 5 m (16.4 ft), with solids up to 2 m (6.562 ft)

### 11.3 Industrial property rights

VEGA product lines are global protected by industrial property rights. Further information see [www.vega.com](http://www.vega.com).

VEGA Produktfamilien sind weltweit geschützt durch gewerbliche Schutzrechte.

Nähere Informationen unter [www.vega.com](http://www.vega.com).

Les lignes de produits VEGA sont globalement protégées par des droits de propriété intellectuelle. Pour plus d'informations, on pourra se référer au site [www.vega.com](http://www.vega.com).

VEGA líneas de productos están protegidas por los derechos en el campo de la propiedad industrial. Para mayor información revise la pagina web [www.vega.com](http://www.vega.com).

Линии продукции фирмы ВЕГА защищаются по всему миру правами на интеллектуальную собственность. Дальнейшую информацию смотрите на сайте [www.vega.com](http://www.vega.com).

VEGA系列产品在全球享有知识产权保护。

进一步信息请参见网站[www.vega.com](http://www.vega.com)。

### 11.4 Trademark

All the brands as well as trade and company names used are property of their lawful proprietor/originator.



Printing date:

**VEGA**

All statements concerning scope of delivery, application, practical use and operating conditions of the sensors and processing systems correspond to the information available at the time of printing.

Subject to change without prior notice

© VEGA Grieshaber KG, Schiltach/Germany 2023



28778-EN-231026

VEGA Grieshaber KG  
Am Hohenstein 113  
77761 Schiltach  
Germany

Phone +49 7836 50-0  
E-mail: [info.de@vega.com](mailto:info.de@vega.com)  
[www.vega.com](http://www.vega.com)