

Operating Instructions

VEGASTAB 690

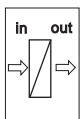
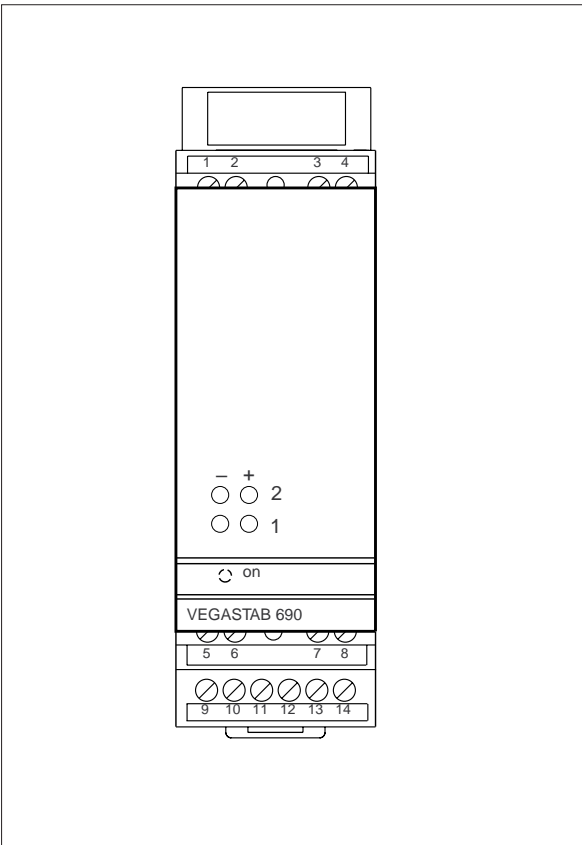

Contents

Safety information 2
 Note Ex area 2

1 Product description

1.1 Function and configuration 3
 1.2 Types and versions 3
 1.3 Technical data 4
 1.4 Dimensions 5

2 Mounting and installation instructions 6

3 Electrical connection

3.1 Connection instructions 7
 3.2 Connection instructions for approved applications 7
 3.3 Connection plan 7
 3.4 Connection examples 8

4 Setup

4.1 Indicating and adjustment elements 9
 4.2 Setup sequence 9

5 Diagnostics

5.1 Maintenance 10
 5.2 Repair 10
 5.3 Checking the measuring cable 10

Safety information

Please read this manual carefully, and also take note of country-specific installation standards as well as all prevailing safety regulations and accident prevention rules.

For safety and warranty reasons, any internal work on the instruments, apart from that involved in normal installation and electrical connection, must be carried out only by qualified VEGA personnel.

Note Ex area

Please note the attached approval documents (yellow binder) and especially the included safety data sheet.

1 Product description

1.1 Function and configuration

VEGASTAB 690 power supply unit is a module instrument with plug-in socket, suitable for carrier rail mounting DIN 46 277.

Function

The power supply unit provides two galvanically separated supply circuits. Both circuits are shortcircuit proof (current limitation approx. 26 mA) and are equipped with interlock diodes for control.

Configuration

VEGASTAB 690 power supply unit can power

- hydrostatic pressure transmitters
- process pressure transmitters or
- differential pressure transmitters

and ensures the configuration of a complete measuring system per circuit in conjunction with one of these sensors.

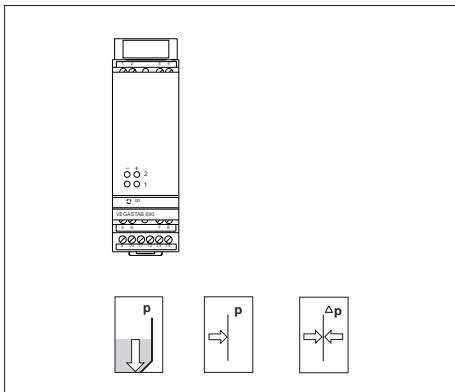

VEGASTAB ...

1.2 Types and versions

Standard application

A power supply unit powers max. two sensors. Both, i.e. power supply unit and sensor form one measuring system.

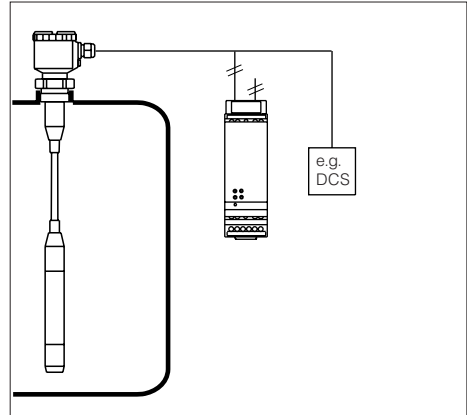

Standard application

Application in Ex area

A power supply unit powers via max. two ia safety barriers type 145 two sensors in Ex area. Together they form one measuring system.

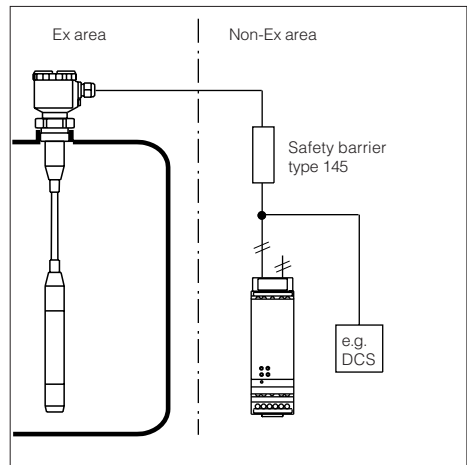

Ex application

1.3 Technical data

Power supply

Operating voltage	20 ... 250 V AC, 50/60 Hz 20 ... 72 V DC with backup power supply curve form deviating considerably from mains sine: $U_{max.} = 125 \text{ V AC (rectangle)}$ max. 3 W (3 ... 16 VA)
Power consumption	
Fuse	
- supply range	T 1 A, 250 V

Electrical connection

Screw terminal	max. 1.5 mm ²
----------------	--------------------------

Electrical protective measures

Protection	
- instrument	IP 30
- plug-in socket	IP 20
Protection class	II
Overtoltage category	II

Ambient conditions

Permissible ambient temperature	-20°C ... +60°C
Storage and transport temperature	-40°C ... +70°C

Output

Output voltage	2 x 24 V DC floating
Current limitation	approx. 26 mA (shortcircuit proof)
Load	
- non-Ex circuit	max. 500 Ohm
- intrinsically safe circuit	max. 75 Ohm (in conjunction with safety barrier type 145)
Interlock diode	for output 1 and 2 max. instrument load 15 Ohm

Indicating elements

LED in front plate	green on: operating voltage on
--------------------	--------------------------------

Electrical separation measures

Reliable separation acc. to VDE 0106, part 1 between	power supply output 1 and output 2
- reference voltage	250 V
- isolation resistance	3 kV

CE conformity

VEGASTAB 690 power supply unit meets the protective regulations of EMC (89/336/EWG) and NSR (73/23/EWG). Conformity has been judged acc. to the following standards:

EMC	Emission	EN 50 081 - 1
	Susceptibility	EN 50 082 - 2
NSR		EN 61 010

1.4 Dimensions

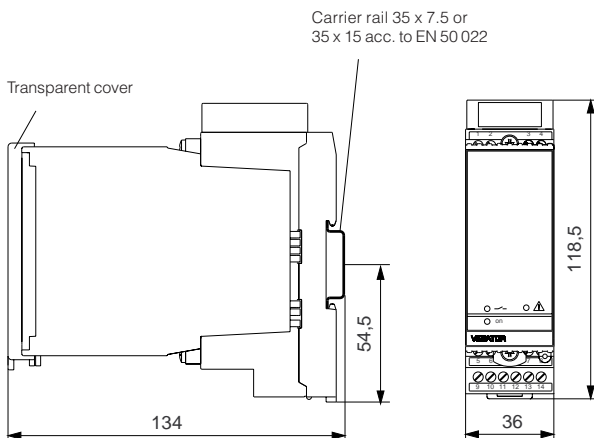

2 Mounting and installation instructions

Mounting

Each series 600 instrument consists of a terminal socket for carrier rail mounting DIN 46 277 and a module unit.

You can connect the supply voltage to terminals 9 and 10.

If there are adjoining series 600 instruments, it is possible to continue the connection L1 and N directly via the supplied jumpers.

Note!

The jumpers must never be used for single instruments or at the end of an instrument row.

Disregard of this warning could lead to coming into contact with the operating voltage, or could generate a short circuit.

Coding

The terminal socket is provided with pins and the instrument with appropriate gaps (mechanical coding) to prevent inadvertent swapping of the different instruments.

Instrument coding by means of differently placed coded pins prevents inadvertent swapping of the different signal conditioning instruments and this power supply unit.

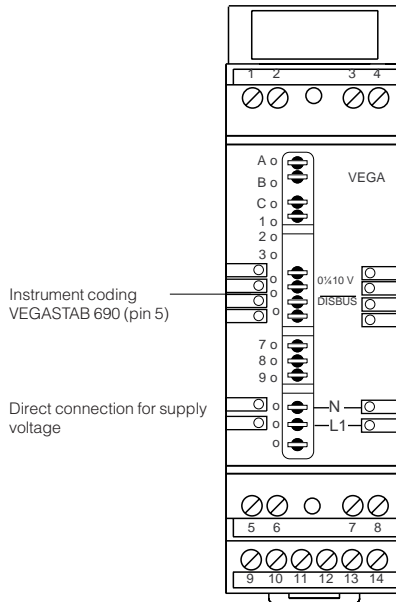

3 Electrical connection

3.1 Connection instructions

The following connection plan is valid for standard as well as for Ex measuring systems. Please observe the following instructions:

- If strong electromagnetic interferences are expected, screened cable is recommended for the signal cables.
- The screening must be earthed only on one (sensor) end.
- If overvoltages are expected, we recommend the use of VEGA overvoltage arresters.
- The connection must be made according to the appropriate national installation standards (e.g. in Germany acc. to the VDE regulations).

3.2 Connection instructions for approved applications



In Ex applications, the voltage supply of the sensor must be provided only via an intrinsically safe circuit.

By using ia safety barriers type 145, intrinsically safe circuits can be prepared, see „3.4 Connection examples“.

Please also note the official document of the ia safety barrier.

3.3 Connection plan

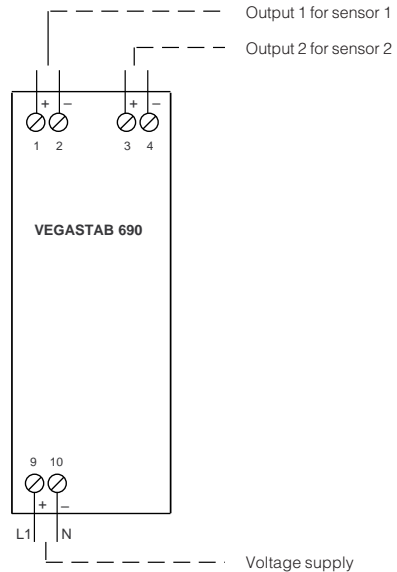

3.4 Connection examples

Sensors in non-Ex area

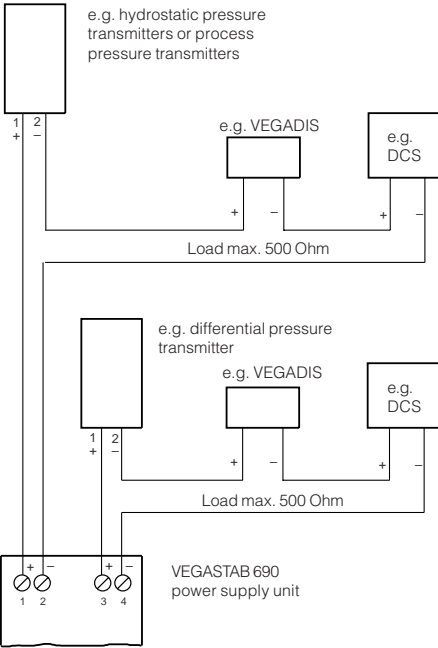

Mixed applications can also be connected to the two outputs of the power supply unit, e.g.

- output 1, sensor in non-Ex area
- output 2, sensor in Ex area.

Sensors in Ex area

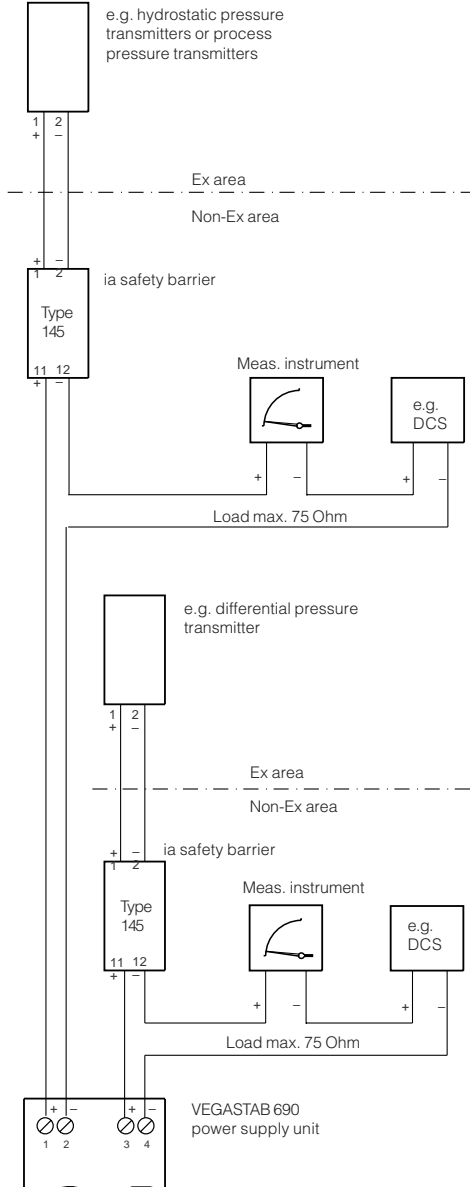

4 Setup

4.1 Indicating and adjustment elements

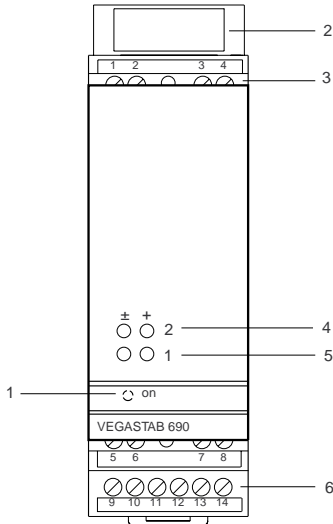

- 1 LED secondary voltage available
- 2 Separating wall
- 3 Terminals output 1 and 2
- 4 Interlock connection sockets output 2
- 5 Interlock connection sockets output 1
- 6 Terminals supply

4.2 Setup sequence

The following listing shows the main setup steps

- mount the terminal socket
- wire the socket acc. to your requirements
- cover the input terminals with the separating wall (2)
- mount the module unit to the terminal socket
- switch on the supply voltage, the green LED (1) lights

5 Diagnostics

5.1 Maintenance

The instrument is maintenance-free.

5.2 Repair

For safety and warranty reasons, any internal work on the instruments, apart from that required in normal installation and connection, must be carried out only by VEGA personnel.

In case of defect, please return the respective instrument with a short description of the fault to our repair department.

5.3 Checking the measuring cable

A measuring instrument connected to the interlock sockets is switched without interruption into the circuit of the measuring cable (series connection). This enables diagnostic checking of the measuring cable. The measuring instrument shows the actual current.

The same procedure is also valid for output 2, measuring cable 2 on the interlock sockets 2.

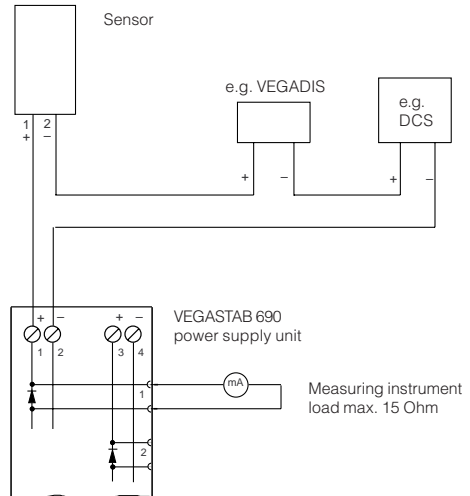

Ex Note!

In Ex systems make sure that the Ex protection is not degraded by the measuring instrument.

VEGA

VEGA Grieshaber KG
Am Hohenstein 113
D-77761 Schiltach
Phone (0 78 36) 50 - 0
Fax (0 78 36) 50 - 201
E-Mail info@de.vega.com
www.vega.com



The statements on types, application, use and operating conditions of the sensors and processing systems correspond to the latest information at the time of printing.

Technical data subject to alterations