

VEGASOURCE 86

Version X (standard version)

Source holder for source capsules

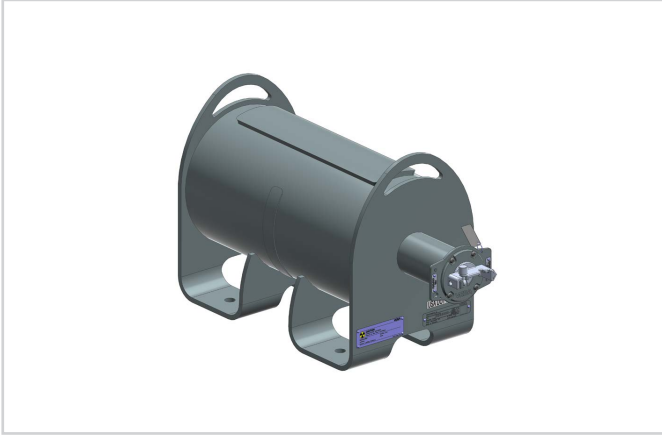

Application area

The VEGASOURCE 86 is used for the reception of a radionuclide which is used as radiation source for the radiometric limit level, level and density measurements. The design of VEGASOURCE 86 offers an optimum shielding and protects the integrated gamma radiator reliably.

Your benefit

- Optimum shielding for worldwide use with the strictest radiation protection requirements
- Exceptional repeatability of ON/OFF switching
- Operational reliability through electrical or pneumatic ON/OFF switching (optional)

Function

The radioactive isotope inside the source holder VEGASOURCE 86 emits gamma rays. The VEGASOURCE 86 is mounted on the vessel or the pipeline, directly opposite the sensor. The source holder shields the environment against the gamma rays and protects the radioactive isotope against mechanical or chemical damage. In case of large measuring ranges, two or more source holders are used.

Technical data

| | |
|---|--|
| Source | Cs-137 Co-60 |
| Shielding material | Lead |
| Outer housing | 316L or steel (1.0619) with PUR textured paint RAL 1018 |
| Number of the half-value layers | 13.8 (attenuation factor F_s 14000) |
| Max. permissible activity of the radioactive source | Cs-137: 370 GBq (10000 mCi) Co-60: 185 GBq (5000 mCi) |
| Exit angle | 5°, 30°, 40° or 45° |
| Width of the exit channel | 10° in all versions |
| Safety facility | Padlock |
| Damping of the useful beam (Co-60) | approx. 0.272 half-value layers (attenuation factor F_s 1.21) With open beam path |
| Ambient, storage and transport temperature | -50 ... +200 °C (-58 ... +392 °F) |
| Flame resistance | +821 °C (+1510 °F) for 30 minutes |
| Weight | approx. 900 kg (1984 lbs) |

Materials

The housing and the mounting holder are made of steel or stainless steel, the internal parts and the source insert of stainless steel. Lead is used as shielding material.

You will find a complete overview of the available materials in the "configurator" on our homepage at www.vega.com/configurator.

Versions

The source container VEGASOURCE 86 is available in different versions that meet the special safety requirements for source handling.

The ON or OFF switch position can be secured with a lock. A version with pneumatic drive for switching on and off (remote control) is available. This version has proximity switches for remote indication of the switching status.

Shipment

Radioactive sources can only be shipped when a handling permit or an import license is available. The transport is carried out in a type A packaging in accordance with the European Agreement concerning the International Carriage of Dangerous Goods (ADR and DGR/IATA). The source holder VEGASOURCE 86 is sufficient as type A packaging (IATA regulations) for the transport of the radioactive source. The source holder is shipped in switch position OFF. The position is secured by a lock.

Approvals

Worldwide approvals are available for VEGA instruments, e.g. for use in hazardous areas.

The technical data in the respective safety instructions are valid for approved instruments (e.g. with Ex approval). In some cases, these data can differ from the data listed herein.

You can find detailed information on the existing approvals with the appropriate product on our homepage.

Adjustment

The radiation may only be switched on by qualified personnel. The radiation is switched on mechanically via a swivelling insert that is rotated clockwise by 180° or via a pneumatic switching mechanism. The switching status is clearly visible via distinct labelling. If it is used properly and the specified ambient and operating conditions are maintained, the source holder requires no maintenance or inspection.

Mounting instructions

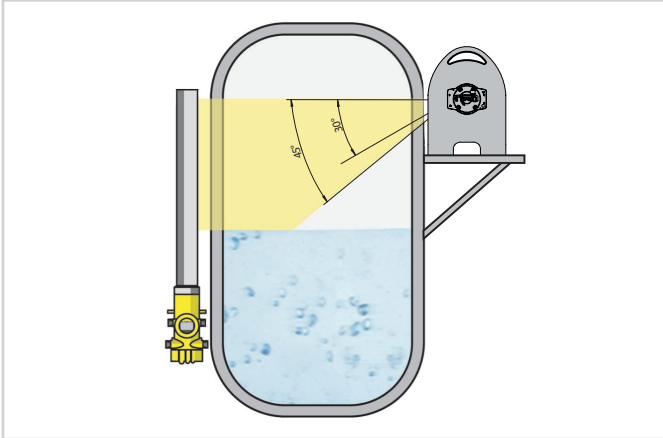

Orientation - Source holder

Beam angle 30° and 45°

The source container can be mounted with a nozzle on the vessel or tube (unpressurized and not in contact with the process). The mounting can be carried out, for example, on L-profiles or a mounting plate. Make sure there is a hole in the mounting plate for the radiation beam to pass through. For continuous level measurement, the source holder must be mounted slightly above or at the height of the max. level. The radiation must be exactly directed to the sensor on the opposite side.

Dimensions

VEGASOURCE 86

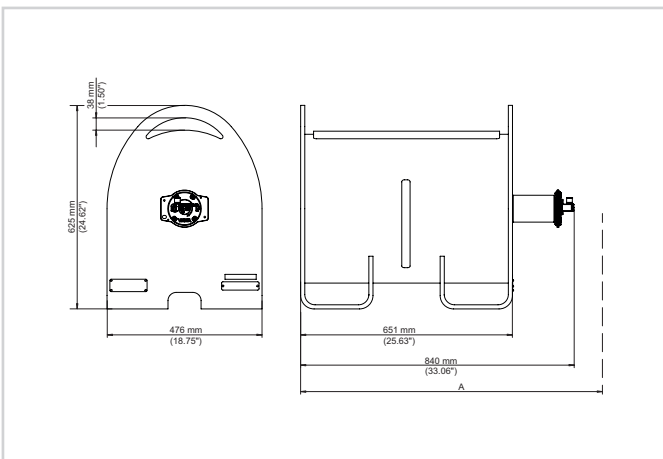

Dimensions VEGASOURCE 86

A 1320 mm (52 in) - free space for source exchange

Mounting holder

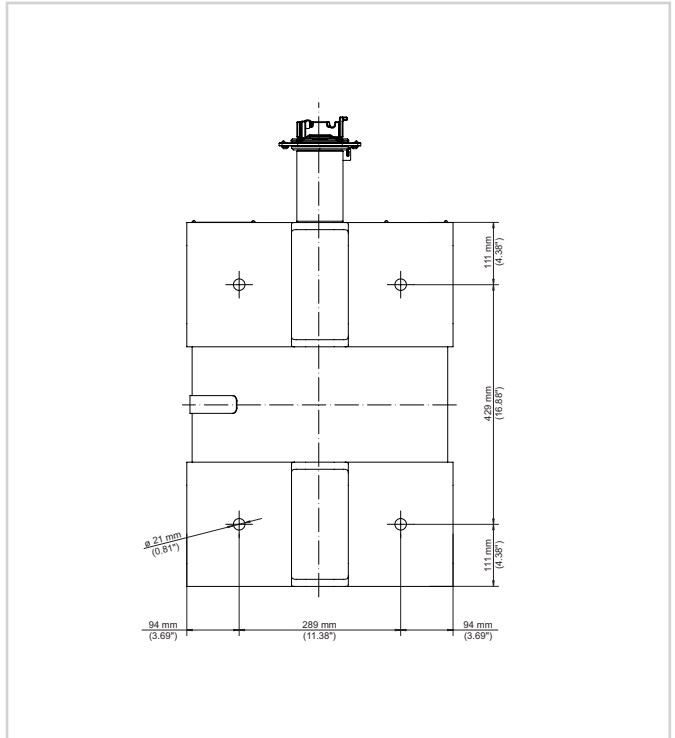

Mounting holder with mounting holes

Information

You can find further information on the VEGA product line on our homepage.

In the download section of our homepage you'll find operating instructions, product information, industry brochures and approval documents as well as device and adjustment software.

Instrument selection

On our homepage under "Products" you can select the suitable measuring principle and instrument for your application.

There you will also find detailed information on the available device versions.

Contact

You can find your personal contact person at VEGA on our homepage under "Contact".