

## Manufacturer declaration

### **EHEDG and 3-A, Installation and Cleaning Instructions**

VEGAPULS 6X, VEGAPULS 42



Document ID: 1020415



**VEGA**

## Contents

<b>1</b>	<b>About this document</b>	<b>3</b>
1.1	Function	3
1.2	Scope	3
<b>2</b>	<b>3-A/-EHEDG-Standards - Meaning and implementation</b>	<b>4</b>
<b>3</b>	<b>Instrument versions</b>	<b>5</b>
<b>4</b>	<b>Mounting</b>	<b>6</b>
<b>5</b>	<b>Maintenance, cleaning, appropriate use</b>	<b>9</b>
<b>6</b>	<b>Manufacturer declaration</b>	<b>11</b>
6.1	3A	11
6.2	EHEDG	11
<b>7</b>	<b>3-A certificate</b>	<b>13</b>
<b>8</b>	<b>EHEDG certificate</b>	<b>17</b>

# 1 About this document

## 1.1 Function

This instructions manual provides the most important information needed for using of level switches.

### **VEGAPULS 6X, VEGAPULS 42**

according to "EHEDG Doc. 8 (2018), 16 (1997), 32 (2005), 37 (2007) and 3-A Sanitary Standard for Sensors and Sensor Fittings and Connections, Number 74".

## 1.2 Scope

These instructions apply to VEGAPULS 6X, VEGAPULS 42 radar sensor with o-ring seal & hygienic process fittings.

You can find the covered versions in Chapter 6.2 in the manufacturer declaration of this document. In Chapter 5 you can find detailed information to the o-ring seal.

The VEGAPULS 6X, VEGAPULS 42 can be operated up to a max. pressure of 25 bar and to a max. process temperature of 150 °C.

## 2 3-A-/EHEDG-Standards - Meaning and implementation

### Meaning of 3-A

3-A Sanitary Standards Incorporation (SSI) in the USA sets standards for materials, design and manufacturing methods for components used in hygienic processes. The organization also monitors compliance with the hygienic design of these components. Conformity is verified by an independent third party CCE (Certified Conformance Evaluator). In the case of conformity, 3-A SSI issues a symbol license for the 3-A logo.

### Meaning of EHEDG

The European Hygienic Engineering & Design Group (EHEDG) is a consortium of equipment and food manufacturers, food industry suppliers, research institutes and universities. The main objective is to promote safe food by improving hygiene technology and design in all areas of food production. To this end, the EHEDG has drawn up guidelines for the hygienic design of machines and plants as well as the infrastructure of food production.

### Use of instruments according to EHEDG and 3-A

For use in the food sector according to EHEDG or 3-A, special requirements apply compared to standard applications. This applies in particular to:

- Version of the housing (e.g. easy cleaning)
- Configuration of the process fitting (e.g. visibility of possible leakage)
- Seals (e.g. according to FDA and EG1935/2004, or resistant to process and cleaning media)
- Installation position on the vessel (e.g. self-drainage)
- Cleaning and maintenance (e.g. intervals, methods)

The EHEDG and 3-A logos prove that the device version has been tested and certified. The certificate always refers to a combination of sensor and process fitting.

**Process fittings****3 Instrument versions**

Only process fittings listed in chapter "*Manufacturer declaration*" may be used for installations according to 3-A/EHEDG standards.

They meet the hygienic requirements of EHEDG Doc. 8 (2018), 16 (1997), 32 (2005) and the 3-A Standard No. 74, including the requirement for self-drainage in the event of a leak in the device seal.

## 4 Mounting

Note the following items for a measuring point according to EHEDG or 3-A standard:

- All parts of the measuring point must comply with 3-A/EHEDG
- The mounting position must allow the self-drainage of the sensor as well as the hole for leakage detection
- The hole for leakage detection in the process fitting must be visible after mounting and possibly point vertically downward
- Welded connections must have a surface roughness  $Ra \leq 0.8 \mu\text{m}$
- Welding sockets must be welded flush with the inside of the vessel. The welding standard AWS D18.3 must be observed for hygienic welding.
- When a welding is necessary for integration of the sensors resp. process connections at plants the EHEDG requirements have to be respected (see Doc. 9 and 35).

### Installation position

In horizontal pipelines, avoid mounting in the upper or lower area of the pipe (see exclusion and limitation in the figure below).

In the upper part of the pipe cavities can form due to air inclusions.

In horizontal pipelines, lateral installation is therefore recommended.

The sensor is optimized for CIP cleaning and does not have to be removed for cleaning.

If the sensor is cleaned manually, do not use tools that damage the PEEK surface of the sensor tip.

When selecting the mounting, make sure that the sensor is positioned so that it empties itself.

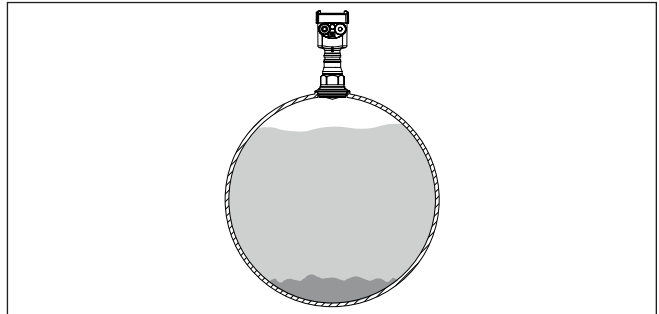

Fig. 1: Installation in horizontal pipelines

x Recommended mounting area

### Hygienic adapter

When installing the hygienic adapter, make sure that the hole for leakage detection in the process fitting is at the lowest possible point.

### Mounting the sensor

For sensor mounting proceed as follows:

1. Avoid contamination when mounting the sensor.

Therefore, only remove the sensor from its packaging shortly before mounting and, in particular, check the sensor tip for damage.

2. Screw in the sensor carefully by hand.  
It is therefore essential that you observe the prescribed torque.  
This leaves a small gap (1) below the hexagon.

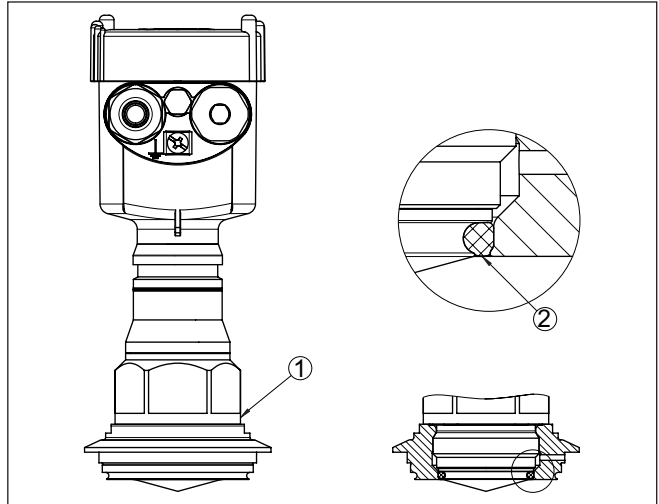

Fig. 2: VEGAPULS 6X, VEGAPULS 42 in hygienic version

- 1 Below the hexagon remains a gap
- 2 Detail of the sealing edge
- A Hygienic version with welding adapter
- B Hygienic version with clamp adapter



**Note:**

The sealing effect of the sensor is optimal when first screwed in. We therefore recommend not screwing in the sensor for test purposes. Before further screwing in, check the sensor tip for damage such as notches or grooves. If in doubt, replace the sensor with a new one.

3. Tighten the sensor on the hexagon with a torque of 50 Nm (36.9 lbf ft).
4. The sensor is mounted.

**Limitation of dead ends**

In cases where mounting in pipe sockets cannot be avoided, short nozzles should be used. Acc. to 3-A Standard 00- the height of the socket (h) can be at most twice as large as the difference between the sensor and the pipe inner diameter (D). The following formula is applicable:  $h = \max. 2D$  (the shorter, the better)

For EHEDG and the design of dead spaces there, the notes in chapter 6.2 must be observed.

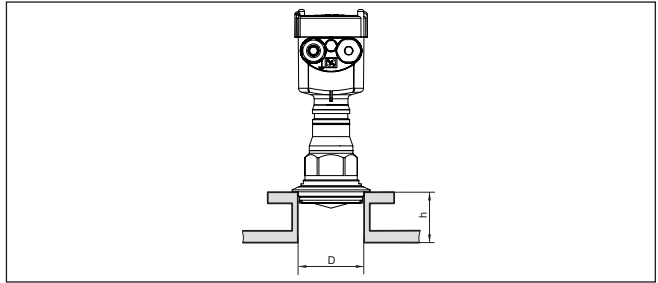

Fig. 3: Socket table

*h* Permissible socket height (sealing surface to tube inner diameter)

*D* Nozzle inner diameter

Formula:  $h = \max. 2D$  (the shorter, the better)



## 5 Maintenance, cleaning, appropriate use

### Maintenance

It is the responsibility of the user to ensure the hygienically safe condition of the sensor during its entire service life.

Leaks in a gasket represent a hygienic risk. To avoid this, they should be checked regularly for damage. Sensor and process adapter form a unit and should be removed together during an inspection. The accessible surface of the sensor must be carefully cleaned.

The user plans the intervals according to the process conditions.

For variants with an O-ring seal, we recommend replacement after 5000 operating hours, at least once every 500 sterilisation or cleaning cycles. When replacing the O-ring, do not use any metallic tools.

### O-ring change

For proper replacement of the O-ring, the following should be carried out in the sequence indicated:

- Push the O-ring out of the seal groove manually
- Clean the seal groove with a suitable cleaning utensil that does not damage the metal
- Check that the cleaned seal groove is free of damage
- Check that the new O-ring is of the correct size and free from damage and cracks
- Sliding on the O-ring
- Check the position of the O-ring and make sure that the O-ring is fitted in the seal groove without twisting

We recommend using O-rings for a quick change of the seal.

For EPDM: article number for the 1" version: 1014644 21.82 x 3.53 or for the 1,5" version: 1012913 EPDM 291 Freudenberg.

For FKM: article number for the 1" version: 2.63690 21.82 x 3.53 or for the 1,5" version: 1007146 34,52 x 3,53 FKM V70SW LLC.

### Cleaning

The sensor is optimized for CIP cleaning and does not have to be removed for the cleaning.

When installing in the tank, make sure that the cleaning fitting is positioned so that the connection as well as the sensor can be completely wetted and cleaned.

If a validation without removal is not possible, it is recommended to remove the unit to ensure successful cleaning.

It is the responsibility of the user to ensure the resistance of the sealing material and the sensor against the product and the cleaning process. This is based on resistance lists and the technical data of the respective sensor.

If the area behind the seal becomes dirty, soak this area with a suitable cleaner and then clean it with a suitable cleaning utensil that does not damage the stainless steel.

### Appropriate use

Salty and acidic foodstuffs such as seasoning concentrates, as well as strongly oxidizing or chlorine-containing cleaning agents, especially at high temperatures and longer exposure times, can also lead to corrosion of stainless steel.

The sensor tip in contact with the medium is made of TECAPEEK natural. The material is also suitable for frequent steam sterilization and hydrolysis resistant to water, steam and salt water. Details on the resistance can be found on <https://www.ensingerplastics.com>.

In order to maintain hygienic integrity, regular visual inspection of the parts in contact with the medium and, if necessary, replacement are recommended.

## 6 Manufacturer declaration

### 6.1 3A

We hereby declare that the instrument and process fitting combinations of the following versions of VEGAPULS 6X, VEGAPULS 42 meet the requirements of 3-A standard 74-07, EHEDG 16 (1997), 32 (2005) and 37 (2007).

VEGAPULS 6X model PS6X(\*\*).\*\*\*aabXccd\*\*\*\*\*D\*\*;

where b = T or H and cc = AJ, A6 or A7 and d = 8 or Z and

where aa = process fitting code: XO for HYGADAPT-X G1 ½ “ and XM for HYGADAPT-L G1” adapters

or aa = process fitting code for firmly connected adapters:

CA, CD, CB, CC, CE, DC, DD, LV, EH, L3, LF, LI, LP, LQ, LC, LK, DE, EA, LJ, EC, ED, LW, L7, LZ, CG, LD, VA, VB, EG, AR, E2, E3, AC, Q6, KW, FR or 7F;

Adapters for VEGAPULS 6X: HYGADAPT-L.Dcc (cc= AT, AR, E2, E3, AD, AC, LV, LD, Q6, KW, FR, FS or 7F);

HYGADAPT-X.Dcc (cc = CA, CD, CB, CC, CE, DC, DD, EH, LV, L3, LF, LI, LP, LQ, LC, LK, DE, EA, LJ, EC, ED, LW, L7, LZ or VB);

VEGAPULS 42 model PS42(\*\*).\*\*DMaaA7\*\*\*\*;

where aa = XX (no adapter) or HYGADAPT-L.Dcc (cc = AT, AR, AS, FS, FR, E3, E2, AC, AD, LV, KW, Q6); A7 = material / seal / process temperature

### 6.2 EHEDG

We hereby declare that the instrument and process fitting combinations of the following versions of VEGAPULS 6X, VEGAPULS 42 meet the requirements of EHEDG 16 (1997), 32 (2005) and 37 (2007).

VEGAPULS 6X model PS6X(\*\*).\*\*\*aabXccd\*\*\*\*\*D\*\*;

where b = T or H and cc = AJ, A6 or A7 and d = 8 or Z and

where aa = process fitting code: XO for HYGADAPT-X G1 ½ “ and XM for HYGADAPT-L G1” adapters

VEGAPULS 42 model PS42(\*\*).\*\*DMaaA7\*\*\*\*;

where aa = XX (no adapter) or HYGADAPT-L.Dcc; A7 = material / seal / process temperature

aa = Process connections / Pipe fittings according to

DIN 11864-1, DIN 11864-1, DIN 11864-1 ISO 2852, DIN 32676

in combination with Tri-Clamp Seals Combifit International B.V., Niederlande,

DIN 11851 in combination with ASEPTO-STAR k-flex Upgrade seals Kieselmann GmbH, Deutschland VARINLINE® with EPDM-O-ring in size F, N EHEDG Doc. 8 (2018), 16 (1997), 32 (2005), 37 (2007) and 3-A Sanitary Standard for Sensors and Sensor Fittings and Connections, Number 7

According to the current EHEDG Position Paper version for sensors mounted in pipe lines the length of dead leg must be smaller than the

inside diameter of it. In the case the sensor protrudes into the dead leg, the length (L) of the dead leg must be  $L \leq (D - d)$ . If the calculation of L results in a dimension which is too small for fixing the connection, then these sizes are excluded. The orientation must allow self-draining of liquids and should not allow air bubbles to accumulate.

For Sensors mounted in tanks should be flush to the inside of the tank wall. If a dead leg exists for technical reasons, it must be ensured that the cleaning device is able to reach the surfaces. The above criteria for L still apply.

In cases where mounting in pipe sockets cannot be avoided, short nozzles should be used. The height of the socket (h) can be most as large as the pipe inner diameter (D).

The formula is:  $h = \max. D$  (the shorter, the better)

## 7 3-A certificate

ISSUE DATE: December 19, 2013

CERTIFICATE AUTHORIZATION NUMBER: 1731



THIS IS TO CERTIFY THAT

VEGA Grieshaber KG

Am Hohenstein 113, Schiltach 77761, Germany

is hereby authorized to continue to apply the  
3-A Symbol to the models of equipment, conforming to 3-A Sanitary Standards for:

Number 74-07

74-07 (Sensors and Sensor Fittings and Connections)

set forth below

CIP Models:

VEGAFLEX 83 model FX83(\*\*).\*\*abbC\*\*d\*\*M  
(a = F, H, G, I), (bb = LJ, LB, LC, LD, LA), (d = 8, Z)

VEGASWING 61 model SWING61(\*\*).\*\*bbbd\*\*(\*);

VEGASWING 63 model SWING63(\*\*).\*\*bbbd\*\*

(bbb = CAA, CB1, CAD, CFP, CDP, LfV, CEP, CAP, LDP, LCP, SGD, SHP, SKA, SK2, SK5, SK6, SLN, SLP, S7P, LAP, RAC, RBC, RCA, RDI, RFP, RDA, RDP, RSP, RWP, TAP, TAA, TAY, TNP, CA1, CAN, CDN, CG1, CEN, LAN, TAN, CBP, RGP, RCI, CA2, CBN, CBB, CBA, CAB, LHP)

(d = X, T, G);

Weld-in sockets VEGA Hygienic Connection (code LAN and LAP for SWING61(\*\*). and SWING63(\*\*).) Weld-in socket ESTA.LA3\*\*

VEGABAR 82 model B/(\*)82.\*\*bbDc\*\*\*\*\*M

(bb = AV, TD, AT, TE, TF, TV, 6C, PC, 4I, QV, KY, ES, UX, FR, FS, TG, TO, AR, AW, AS, E2, AD, AC, AX, KQ, FF, PS, VI, E3, UJ, U5, UQ, SD, SE, UP, VG, EI, EJ, EK, EL, 6H, 4D, UB, TW, G9, 7P, AY, 5F, 8F, UO, US, UW, G9, 3Z);

(c = G, P, Q, V, W)

VEGABAR 83 model B/(\*)83.\*\*bbc\*\*\*\*\*M

(bb = E2, E3, FR, FS, AR, AT, TE, KY, AW, AS, AC, KW, ES, Q4, Q6, FF, LX),

(c = S, 3, P, E, C, Q, F, N, H, T); where bb = LX, Hygadapt-L is to be used.

Additional options for VEGABAR only: weld-in socket VEGA Hygienic Connection ES, model codes WDSB80.ESM\*G\*\*M and WDSB80.UXM\*G\*\*M;

VEGAPOINT 11 model P11(\*\*).aAC\* and VEGAPOINT 21, model P21(\*\*).\*\*\*\*aAC\*\*

(a = A or D) with adapters:

HYGADAPT-P.acc (a = A or D), (cc = AT, AR, U5, E2, E3, BA, AD, AC, KA, Q6, KW, FR, FS, 7F).

VEGAPOINT 21 model P21(\*\*).\*\*\*\*aAb\*\*\* (a = A, D), (b = C, N, P, Q, F);

VEGAPOINT 24 model P24(\*\*).\*\*\*aAb\*\*\* where a = A or D and b = N, P, or Q;

VEGAPOINT 11 model P11(\*\*).aAF\*, VEGAPOINT 21 model P21(\*\*).\*\*\*\*aAF\*\*\* and  
VEGAPOINT 24 model P24(\*\*).\*\*\*[A or D]AF\*\*\*  
with adapters HYGADAPT-L.acc (a = A, D), (cc = AR, AS, AT, E2, E3, AD, AC, LV, Q6, KW, FR, FS,  
7F, 7G)

VEGABAR 29, model B29(\*\*).\*\*\*abb\*\*\*\* and  
VEGABAR 39, model B39(\*\*).\*\*\*abb\*\*\*\*  
(a = A or D), (bb = AV, AT, AR, FR, FS, E2, U5);

VEGABAR 29, model B29(\*\*).\*\*\*aLX\*\*\*\* and  
VEGABAR 39, model B39(\*\*).\*\*\*aLX\*\*\*\* (a = A, D);  
with HYGADAPT-L.acc (a = A or D), (cc = AR, AS, AT, E2, E3, AD, AC, LV, Q6, KW, FR, FS, 7F, 7G);

VEGAPULS 6X model PS6X(\*\*).\*\*\*aabXccd\*\*\*\*\*D\*\*;  
where b = T or H and cc = AJ, A6 or A7 and d = 8 or Z and  
where aa = process fitting code: XO for HYGADAPT-X G1 ½ " and XM for HYGADAPT-L G1" adapters  
or aa = process fitting code for firmly connected adapters:  
CA, CD, CB, CC, CE, DC, DD, LV, EH, L3, LF, LI, LP, LC, LK, EC, ED, LW, L7, LZ, CG, LD, VA, VB,  
AR, E2, E3, AC, Q6, KW, FR or 7F;

Adapters for VEGAPULS 6X:

HYGADAPT-L.Dcc (cc = AR, AS, AT, E2, E3, AD, AC, LV, Q6, KW, FR, 7F, 7G);

HYGADAPT-X.Dcc (cc = CA, CD, CB, CC, CE, DC, DD, EH, L3, LF, LI, LP, LC, LK, EC, ED, LW, L7,  
LZ or VB);

VEGAPULS 42 model PS42(\*\*).\*\*DMaaA7\*\*\*\*;  
where aa = XX (no adapter) or HYGADAPT-L.Dcc (cc = AR, AS, AT, FS, FR, E2, E3, AC, AD, LV, KW,  
Q6, 7F, 7G); A7 = material / seal / process temperature

VALID THROUGH: **December 31, 2024**

The issuance of this authorization for the use of the 3-A Symbol is based upon the voluntary certification, by the applicant for it, that the equipment listed above complies fully with the 3-A Sanitary Standard(s) designated. Legal responsibility for compliance is solely that of the holder of this Certificate of Authorization, and 3-A Sanitary Standards, Inc. does not warrant that the holder of an authorization at all times complies with the provisions of the said 3-A Sanitary Standards. This in no way affects the responsibility of 3-A Sanitary Standards, Inc. to take appropriate action in such cases in which evidence of nonconformance has been established.

NEXT TPV INSPECTION/REPORT DUE: **October 2028**

ISSUE DATE: June 04, 2003

CERTIFICATE AUTHORIZATION NUMBER: 1260



THIS IS TO CERTIFY THAT

VEGA Americas, Inc.

3877 Mason Research Pkwy, Mason, OH 45036

is hereby authorized to continue to apply the  
3-A Symbol to the models of equipment, conforming to 3-A Sanitary Standards for:

Number 74-07  
74-07 (Sensors and Sensor Fittings and Connections)

set forth below

CIP Model(s):

VEGAFLEX 83 model FX83(\*\*)\*\*abbC\*\*d\*\*M  
(a = F, H, G, I), (bb = LJ, LB, LC, LD, LA), (d = 8, Z)

VEGAPULS 63 model PS63(\*\*)\*\*Nbb\*d\*\*X  
(bb = CA, CB, CC, CD, DC, DD, LC, EC, LK), (d = 8, Z)

VEGAPULS 64 model PS64(\*\*)\*\*abbC\*\*d\*\*M  
(a = H, I), (bb = CA, CB, CC, CD, DC, DD, LC, EC, LK), (c = I, J), (d = 8, Z)

VEGASWING 61 model SWING61(\*\*)\*\*bbbd\*\*(\*)

VEGASWING 63 model SWING63(\*\*)\*\*bbbd\*\*

(bbb = CAA, CB1, CAD, CFP, CDP, LfV, CEP, CAP, LDP, LCP, SGD, SHP,  
SKA, SK2, SK5, SK6, SLN, SLP, S7P, LAP, RAC, RBC, RCA, RDI, RFP, RDA,  
RDP, RSP, RWP, TAP, TAA, TAY, TNP, CA1, CAN, CDN, CG1, CEN, LAN, TAN,  
CBP, RGP, RCI, CA2, CBN, CBB, CBA, CAB, LHP)  
(d = X, T, G);

Weld-in sockets VEGA Hygienic Connection (code LAN and LAP for SWING61(\*\*). and  
SWING63(\*\*).) Weld-in socket ESTA.LA3\*\*;

VEGABAR 82 model B(\*)82.\*\*bbc\*\*\*\*\*M

(bb = AV, TD, AT, TE, TF, TV, 6C, PC, 4I, QV, KY, ES, UX, FR, FS, TG, TO, AR, AW, AS, E2, AD, AC,  
AX, KQ, ES, FF, PS, VI, E3, UJ, U5, UQ, SD, SE, UP, VG, EI, EJ, EK, EL, 6H, 4D, UB, TW, G9, 7P,  
AY, 5F, 8F, UO, US, UW, G9, 3Z); (c = D, F, G, P, Q, V, W);

VEGABAR 83 model B(\*)83.\*\*bbc\*\*\*\*\*M

(bb = E2, E3, FR, FS, AR, AT, TE, KY, AW, AS, AC, KW, ES, Q4, Q6, FF, LX),  
(c = S, 3, P, E, C, Q, F, N, H, T)

Additional options for VEGABAR only: weld-in socket VEGA Hygienic Connection ES, model codes  
WDSB80.ESM\*G\*\*M and WDSB80.UXM\*G\*\*M;

VEGAPOINT 11 model P11(\*\*).aAC\* and VEGAPOINT 21, model P21(\*\*).\*\*\*\*aAC\*\*

1020415-EN-231207

(a = A or D) with adapters:

HYGADAPT-P.acc (a = A or D), (cc = AT, AR, U5, E2, E3, BA, AD, AC, KA, Q6, KW, FR, FS, 7F);

VEGAPOINT 21 model P21(\*\*).\*\*\*\*aAb\*\*\* (a = A, D), (b = C, N, P, Q, F);

VEGAPOINT 24 model P24(\*\*).\*\*\*aAb\*\*\* where a = A or D and b = N, P, or Q;

VEGAPOINT 11 model P11(\*\*).aAF\*, VEGAPOINT 21 model P21(\*\*).\*\*\*\*aAF\*\*\* and  
VEGAPOINT 24 model P24(\*\*).\*\*\*[A or D]AF\*\*\*  
with adapters HYGADAPT-L.acc (a = A, D), (cc = AT, AR, E2, E3, AD, AC, Q6, KW, FR, FS, 7F, 7G);

VEGABAR 29, model B29(\*\*).\*\*\*abb\*\*\*\* and  
VEGABAR 39, model B39(\*\*).\*\*\*abb\*\*\*\*  
(a = A or D), (bb = AV, AT, AR, FR, FS, E2, U5);

VEGABAR 29, model B29(\*\*).\*\*\*aLX\*\*\*\* and  
VEGABAR 39, model B39(\*\*).\*\*\*aLX\*\*\*\* (a = A, D);  
with HYGADAPT-L.acc (a = A or D), (cc = AT, AR, E2, E3, AD, AC, Q6, KW, FR, FS, 7F).

VALID THROUGH: **December 31, 2024**

The issuance of this authorization for the use of the 3-A Symbol is based upon the voluntary certification, by the applicant for it, that the equipment listed above complies fully with the 3-A Sanitary Standard(s) designated. Legal responsibility for compliance is solely that of the holder of this Certificate of Authorization, and 3-A Sanitary Standards, Inc. does not warrant that the holder of an authorization at all times complies with the provisions of the said 3-A Sanitary Standards. This in no way affects the responsibility of 3-A Sanitary Standards, Inc. to take appropriate action in such cases in which evidence of nonconformance has been established.

NEXT TPV INSPECTION/REPORT DUE: **August 2027**



8 EHEDG certificate

CERTIFICATE OF COMPLIANCE



EL Class I

Date of issue: 13 April 2023

Valid until: 31 December 2024

EHEDG hereby declares that the product

**VEGAPULS 6X /42 with threaded adapters with EPDM or FKM gasket**

from

VEGA Grieshaber KG, Am Hohenstein 113, 77761 Schiltach, Germany

has/have been evaluated for compliance and meets/meet the current criteria for Hygienic Equipment Design of the EHEDG

**Certificate No. EHEDG-C2300025**

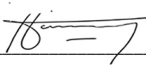
Signed  President EHEDG  
Hein Timmerman

Signed  EHEDG Certification Officer  
Karlijn Faber

EHEDG  
Karspeldreef 8  
1101 CJ Amsterdam  
Netherlands

©EHEDG



1020415-EN-231207

A large grid of graph paper for taking notes, consisting of 20 columns and 30 rows of small squares.

The page contains a large grid of 20 columns and 40 rows, intended for handwritten notes. The grid is composed of thin grey lines on a white background.

1020415-EN-231207

Printing date:

**VEGA**

All statements concerning scope of delivery, application, practical use and operating conditions of the sensors and processing systems correspond to the information available at the time of printing.

Subject to change without prior notice

© VEGA Grieshaber KG, Schiltach/Germany 2023



1020415-EN-231207

VEGA Grieshaber KG  
Am Hohenstein 113  
77761 Schiltach  
Germany

Phone +49 7836 50-0  
E-mail: [info.de@vega.com](mailto:info.de@vega.com)  
[www.vega.com](http://www.vega.com)