

# Operating Instructions

Vibrating level switch for liquids

## VEGASWING 53

IO-Link



Document ID: 61863



# VEGA

# Contents

<b>1</b>	<b>About this document</b>	<b>3</b>
1.1	Function	3
1.2	Target group	3
1.3	Symbols used	3
<b>2</b>	<b>For your safety</b>	<b>4</b>
2.1	Authorised personnel	4
2.2	Appropriate use	4
2.3	Warning about incorrect use	4
2.4	General safety instructions	4
2.5	Safety label on the instrument	5
2.6	Conformity	5
2.7	Installation and operation in the USA and Canada	5
2.8	Environmental instructions	5
<b>3</b>	<b>Product description</b>	<b>6</b>
3.1	Configuration	6
3.2	Principle of operation	6
3.3	Adjustment	7
3.4	Supplementary cleaning procedures	7
3.5	Packaging, transport and storage	8
<b>4</b>	<b>Mounting</b>	<b>9</b>
4.1	General instructions	9
4.2	Mounting instructions	11
<b>5</b>	<b>Connecting to power supply</b>	<b>13</b>
5.1	Preparing the connection	13
5.2	Wiring plan	13
<b>6</b>	<b>Setup</b>	<b>15</b>
6.1	Indication of the switching status	15
6.2	Simulation	15
6.3	Function table	16
<b>7</b>	<b>Maintenance and fault rectification</b>	<b>17</b>
7.1	Maintenance	17
7.2	Rectify faults	17
7.3	How to proceed if a repair is necessary	18
<b>8</b>	<b>Dismount</b>	<b>19</b>
8.1	Dismounting steps	19
8.2	Disposal	19
<b>9</b>	<b>Supplement</b>	<b>20</b>
9.1	Technical data	20
9.2	Device communication IO-Link	23
9.3	Dimensions	25
9.4	Industrial property rights	28
9.5	Trademark	28

# 1 About this document

## 1.1 Function

This instruction provides all the information you need for mounting, connection and setup as well as important instructions for maintenance, fault rectification, the exchange of parts and the safety of the user. Please read this information before putting the instrument into operation and keep this manual accessible in the immediate vicinity of the device.

## 1.2 Target group

This operating instructions manual is directed to trained personnel. The contents of this manual must be made available to the qualified personnel and implemented.

## 1.3 Symbols used



### Document ID

This symbol on the front page of this instruction refers to the Document ID. By entering the Document ID on [www.vega.com](http://www.vega.com) you will reach the document download.



**Information, note, tip:** This symbol indicates helpful additional information and tips for successful work.



**Note:** This symbol indicates notes to prevent failures, malfunctions, damage to devices or plants.



**Caution:** Non-observance of the information marked with this symbol may result in personal injury.



**Warning:** Non-observance of the information marked with this symbol may result in serious or fatal personal injury.



**Danger:** Non-observance of the information marked with this symbol results in serious or fatal personal injury.



### Ex applications

This symbol indicates special instructions for Ex applications.



### List

The dot set in front indicates a list with no implied sequence.



### Sequence of actions

Numbers set in front indicate successive steps in a procedure.



### Disposal

This symbol indicates special instructions for disposal.

## 2 For your safety

### 2.1 Authorised personnel

All operations described in this documentation must be carried out only by trained, qualified personnel authorised by the plant operator.

During work on and with the device, the required personal protective equipment must always be worn.

### 2.2 Appropriate use

The VEGASWING 53 is a sensor for point level detection.

You can find detailed information about the area of application in chapter " *Product description*".

Operational reliability is ensured only if the instrument is properly used according to the specifications in the operating instructions manual as well as possible supplementary instructions.

For safety and warranty reasons, any invasive work on the device beyond that described in the operating instructions manual may be carried out only by personnel authorised by the manufacturer. Arbitrary conversions or modifications are explicitly forbidden.

### 2.3 Warning about incorrect use

Inappropriate or incorrect use of this product can give rise to application-specific hazards, e.g. vessel overflow through incorrect mounting or adjustment. Damage to property and persons or environmental contamination can result. Also, the protective characteristics of the instrument can be impaired.

### 2.4 General safety instructions

This is a state-of-the-art instrument complying with all prevailing regulations and directives. The instrument must only be operated in a technically flawless and reliable condition. The operator is responsible for the trouble-free operation of the instrument. When measuring aggressive or corrosive media that can cause a dangerous situation if the instrument malfunctions, the operator has to implement suitable measures to make sure the instrument is functioning properly.

The safety instructions in this operating instructions manual, the national installation standards as well as the valid safety regulations and accident prevention rules must be observed by the user.

For safety and warranty reasons, any invasive work on the device beyond that described in the operating instructions manual may be carried out only by personnel authorised by the manufacturer. Arbitrary conversions or modifications are explicitly forbidden. For safety reasons, only the accessory specified by the manufacturer must be used.

To avoid any danger, the safety approval markings and safety tips on the device must also be observed.

## 2.5 Safety label on the instrument

The safety approval markings and safety tips on the device must be observed.

## 2.6 Conformity

The device complies with the legal requirements of the applicable country-specific directives or technical regulations. We confirm conformity with the corresponding labelling.

The corresponding conformity declarations can be found on our homepage.

## 2.7 Installation and operation in the USA and Canada

This information is only valid for USA and Canada. Hence the following text is only available in the English language.

Installations in the US shall comply with the relevant requirements of the National Electrical Code (ANSI/NFPA 70).

Installations in Canada shall comply with the relevant requirements of the Canadian Electrical Code.

## 2.8 Environmental instructions

Protection of the environment is one of our most important duties. That is why we have introduced an environment management system with the goal of continuously improving company environmental protection. The environment management system is certified according to DIN EN ISO 14001.

Please help us fulfil this obligation by observing the environmental instructions in this manual:

- Chapter "*Packaging, transport and storage*"
- Chapter "*Disposal*"

## 3 Product description

### 3.1 Configuration

#### Scope of delivery

The scope of delivery encompasses:

- VEGASWING 53 point level switch
- Test magnet
- Documentation
  - This operating instructions manual
  - If necessary, certificates

#### Constituent parts

The VEGASWING 53 consists of the components:

- Housing with electronics
- Process fitting with tuning fork



Fig. 1: VEGASWING 53

#### Type label

The type label contains the most important data for identification and use of the instrument:

- Article number
- Serial number
- Technical data

With the serial number, you can access the delivery data of the instrument via "[www.vega.com](http://www.vega.com)", "Search". You can find the serial number on the inside of the instrument as well as on the type label on the outside.

### 3.2 Principle of operation

#### Application area

VEGASWING 53 is a point level sensor with tuning fork for point level detection.

It is designed for industrial use in all areas of process technology and can be used in liquids.

Typical applications are overflow and dry run protection. With a tuning fork of only 38 mm length, VEGASWING 53 can be also mounted e.g.

in pipelines from DN 25. The small tuning fork allows use in vessels, tanks and pipes. Thanks to its simple and robust measuring system, VEGASWING 53 is virtually unaffected by the chemical and physical properties of the liquid.

It functions even under difficult conditions such as turbulence, air bubbles, foam generation, buildup, strong external vibration or changing products.

### Function monitoring

The electronics module of VEGASWING 53 continuously monitors the following criteria via frequency evaluation:

- Strong corrosion or damage on the tuning fork
- Loss of vibration
- Line break to the piezo drive

If a malfunction is detected or in case of voltage supply, the electronics takes on a defined switching status, i.e. the output is open (safe state).

### Functional principle

The tuning fork is piezoelectrically energised and vibrates at its mechanical resonance frequency of approx. 1100 Hz. When the tuning fork is submerged in the product, the frequency changes. This change is detected by the integrated electronics module and converted into a switching command.

### Voltage supply

VEGASWING 53 is a compact instrument, i.e. it can be operated without external evaluation system. The integrated electronics evaluates the level signal and outputs a switching signal. With this switching signal, a connected device can be operated directly (e.g. a warning system, a pump etc.).

The data for power supply are specified in chapter " *Technical data*".

## 3.3 Adjustment

The switching status of VEGASWING 53 can be checked when the housing is closed (signal lamp). Products with a density  $> 0.7 \text{ g/cm}^3$  ( $0.025 \text{ lbs/in}^3$ ) or ordered optionally with a density  $> 0.5 \text{ g/cm}^3$  ( $0.018 \text{ lbs/in}^3$ ) can be detected.

## 3.4 Supplementary cleaning procedures

### 3.4.1 Oil, grease and silicone-free

The VEGASWING 53 is also available in the version " *Oil, grease and silicone-free*". These instruments have passed through a special cleaning procedure to remove oil, grease and paint-wetting impairment substances (PWIS).

The cleaning is carried out on all wetted parts as well as on surfaces accessible from outside. To keep the purity level, the instruments are immediately packed in plastic foil after the cleaning process. The purity level remains as long as the instrument is kept in the closed original packaging.

**Caution:**

The VEGASWING 53 in this version must only be used in oxygen applications.

### 3.5 Packaging, transport and storage

#### Packaging

Your instrument was protected by packaging during transport. Its capacity to handle normal loads during transport is assured by a test based on ISO 4180.

The packaging of standard instruments consists of environment-friendly, recyclable cardboard. For special versions, PE foam or PE foil is also used. Dispose of the packaging material via specialised recycling companies.

#### Transport

Transport must be carried out in due consideration of the notes on the transport packaging. Nonobservance of these instructions can cause damage to the device.

#### Transport inspection

The delivery must be checked for completeness and possible transit damage immediately at receipt. Ascertained transit damage or concealed defects must be appropriately dealt with.

#### Storage

Up to the time of installation, the packages must be left closed and stored according to the orientation and storage markings on the outside.

Unless otherwise indicated, the packages must be stored only under the following conditions:

- Not in the open
- Dry and dust free
- Not exposed to corrosive media
- Protected against solar radiation
- Avoiding mechanical shock and vibration

#### Storage and transport temperature

- Storage and transport temperature see chapter " *Supplement - Technical data - Ambient conditions*"
- Relative moisture 20 ... 85 %



## 4 Mounting

### 4.1 General instructions

#### Process conditions



#### Note:

For safety reasons, the instrument must only be operated within the permissible process conditions. You can find detailed information on the process conditions in chapter " *Technical data*" of the operating instructions or on the type label.

Hence make sure before mounting that all parts of the instrument exposed to the process are suitable for the existing process conditions.

These are mainly:

- Active measuring component
- Process fitting
- Process seal

Process conditions in particular are:

- Process pressure
- Process temperature
- Chemical properties of the medium
- Abrasion and mechanical influences

#### Suitability for the ambient conditions

The instrument is suitable for standard and extended ambient conditions acc. to DIN/EN/IEC/ANSI/ISA/UL/CSA 61010-1. It can be used indoors as well as outdoors.

#### Switching point

In general, VEGASWING 53 can be installed in any position. The instrument only has to be mounted in such a way that the tuning fork is at the height of the desired switching point.

Keep in mind that the switching point can vary dependent on the installation position.

The switching point refers to the medium water (1 g/cm<sup>3</sup>/0.036 lbs/in<sup>3</sup>). Please keep in mind that the switching point of the instrument shifts when the medium has a density differing from water.

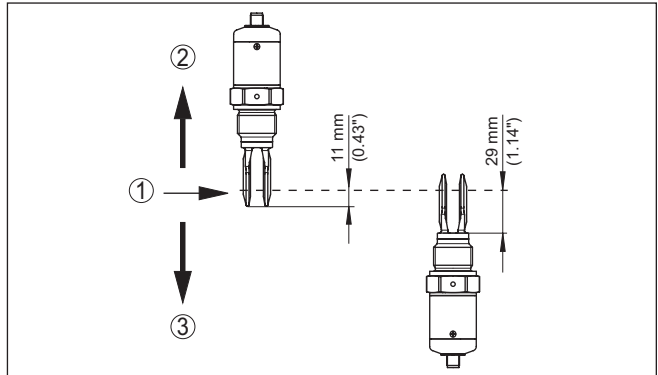

Fig. 2: Vertical mounting

- 1 Switching point in water
- 2 Switching point with lower density
- 3 Switching point with higher density

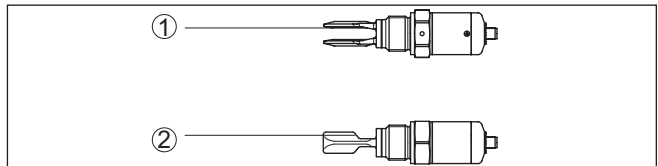

Fig. 3: Horizontal mounting

- 1 Switching point
- 2 Switching point (recommended mounting position, particularly for adhesive products)

## Moisture

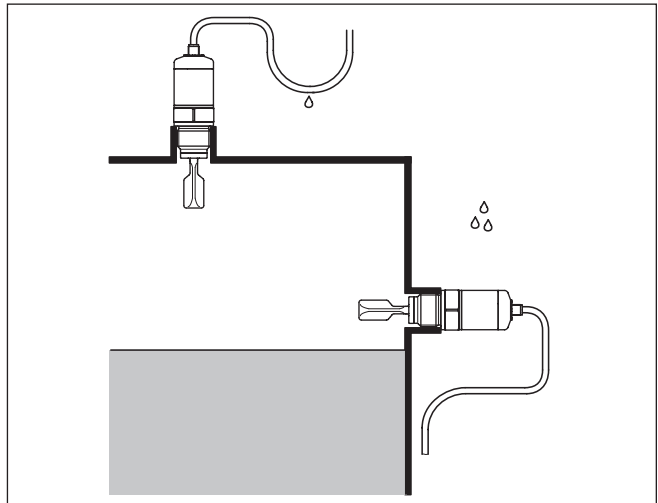

Fig. 4: Measures against moisture ingress

**Transport**

Do not hold VEGASWING 53 on the tuning fork.

**Pressure/Vacuum**

The process fitting must be sealed if there is gauge or low pressure in the vessel. Before use, check if the sealing material is resistant against the measured product and the process temperature.

The max. permissible pressure is specified in chapter " *Technical data*" or on the type label of the sensor.

**Handling**

The vibrating level switch is a measuring instrument and must be treated accordingly. Bending the vibrating element will destroy the instrument.



**Warning:**

The housing must not be used to screw the instrument in! Applying tightening force can damage internal parts of the housing.

Use the hexagon above the thread for screwing in.

**4.2 Mounting instructions**

**Welded socket**

For threaded versions of VEGASWING 53 in combination with a mounting boss with O-ring in front and welding marking.

VEGASWING 53 with thread sizes 1/2", 3/4" and 1" have a defined thread. This means that every VEGASWING 53 is in the same position after being screwed in. Remove therefore the supplied flat seal from the thread of VEGASWING 53. This flat seal is not required when using a welded socket with front-flush seal.

Before welding, unscrew VEGASWING 53 and remove the rubber ring from the welded socket.

The welded socket is provided with a marking (notch). With horizontal mounting, weld the socket with the notch facing upward or downward; in pipelines (DN 25 to DN 50) aligned with the direction of flow.

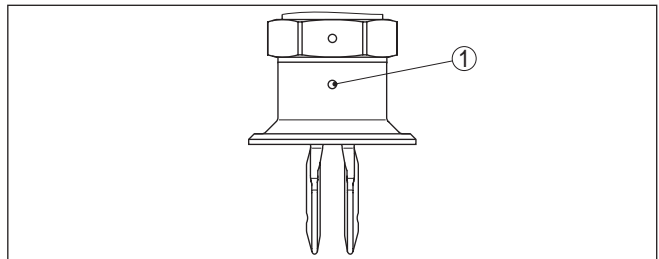

Fig. 5: Marking on the welded socket

1 Marking

**Adhesive products**

In case of horizontal mounting in adhesive and viscous media, the surfaces of the tuning fork should be vertical in order to reduce build-up on the tuning fork. The position of the tuning fork is indicated by a marking on the hexagon of VEGASWING 53. With this, you can check the position of the tuning fork when screwing it in. When the hexagon touches the seal, the thread can still be turned by approx. half a turn. This is sufficient to reach the recommended installation position.

In adhesive and viscous media, the surfaces of the tuning fork should protrude into the vessel to avoid buildup. Therefore nozzles for flanges and mountings bosses should not exceed a certain length.

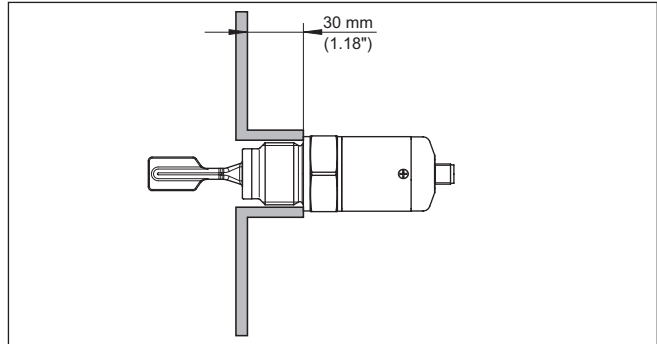

Fig. 6: Adhesive products

#### Inflowing medium

If VEGASWING 53 is mounted in the filling stream, unwanted false measurement signals can be generated. For this reason, mount VEGASWING 53 at a position in the vessel where no disturbances, e.g. from filling openings, agitators, etc., can occur.

#### Product flow

To make sure the tuning fork of VEGASWING 53 generates as little resistance as possible to product flow, mount the sensor so that the surfaces are parallel to the product movement.

#### Agitators

Due to the effects of agitators, equipment vibration or similar, the level switch can be subjected to strong lateral forces. For this reason, do not use an overly long extension tube for VEGASWING 53, but check if you can mount a short vibrating level switch on the side of the vessel in horizontal position.

Extreme vibration caused by the process or the equipment, e.g. agitators or turbulence in the vessel, can cause the extension tube of VEGASWING 53 to vibrate in resonance. This leads to increased stress on the upper weld joint. Should a longer tube version be necessary, you can provide a suitable support directly above the tuning fork to secure the extension tube.

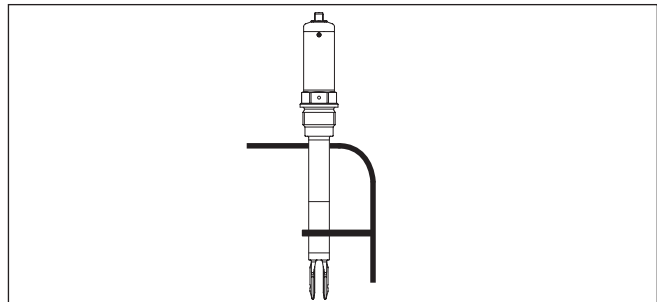

Fig. 7: Lateral support of VEGASWING 53

## 5 Connecting to power supply

### 5.1 Preparing the connection

**Note safety instructions**

Always keep in mind the following safety instructions:



**Warning:**

Connect only in the complete absence of line voltage.

- The electrical connection must only be carried out by trained, qualified personnel authorised by the plant operator.
- Always switch off power supply, before connecting or disconnecting the instrument.

**Connection cable**

The instrument is connected with standard three-wire cable without shielding. If electromagnetic interference is expected which is above the test values of EN 61326 for industrial areas, shielded cable should be used.

Make sure that the cable used has the required temperature resistance and fire safety for max. occurring ambient temperature

### 5.2 Wiring plan

**Housing overview**

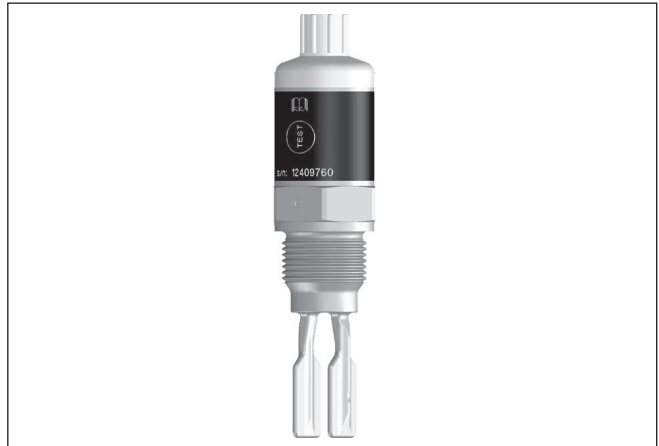

Fig. 8: Connection variant - M12 x 1 plug

**Plug versions**

**M12 x 1 plug connection**

This plug connection requires a prefabricated cable with plug. Depending on the version, protection IP66/IP67 or IP68 (0.2 bar).

**IO-Link**

For connection to binary inputs of a PLC.

For power supply, use an energy-limited circuit according to EN 61010.

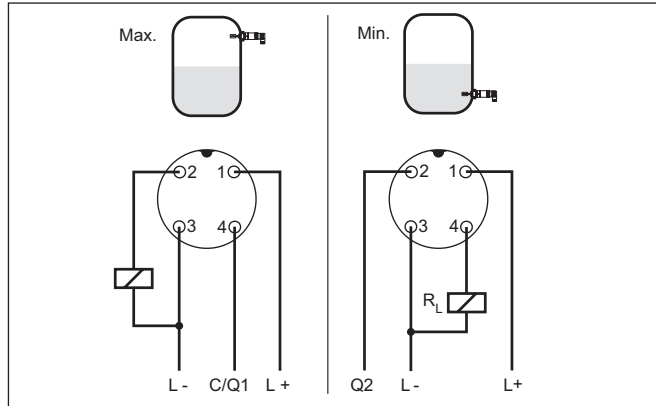

Fig. 9: Wiring plan (housing), terminal assignment IO-link output with M12 x 1 plug connection

- 1 L+ Voltage supply (brown)
  - 2 Max. level detection (white)
  - 3 L- Voltage supply (blue)
  - 4 Min. level detection/IO-Link communication (black)
- $R_L$  Load resistance (contactor, relay, etc.)

## 6 Setup

### 6.1 Indication of the switching status

The switching status of the electronics can be checked via the signal lamps (LEDs) integrated in the upper part of the housing.

The signal lamps have the following meaning:

- Green lights - voltage supply connected
- Yellow lights - vibrating element covered
- Red lights briefly - function test during instrument start (for approx. 1 s)
- Red lights - shortcircuit or overload in the load circuit (sensor output high-impedance)
- Red flashes - Error on the vibrating element or the electronics (sensor output high impedance)

### 6.2 Simulation

The VEGASWING 53 has an integrated function for simulation of the output signal which can be activated magnetically. Please proceed as follows:

- Hold the test magnet (accessory) against the circle symbol with the label "TEST" on the instrument housing

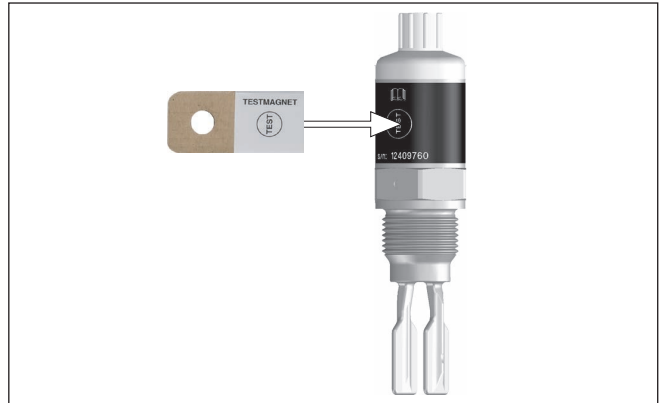

Fig. 10: Simulation of the output signal

The test magnet changes the current switching condition of the instrument. You can check the change on the signal lamp. Please note that all connected device are activated during the simulation.

If VEGASWING 53 does not switch over after several tests with the test magnet, you have to check the plug connection and the connection cable and try it again. If there is no switching function, the electronics will be defective. In this case you have to exchange the electronics or return the instrument to our repair department.

**Caution:**

It is absolutely necessary that you remove the test magnet from the instrument housing after the simulation.

**6.3 Function table**

The following table provides an overview of the switching conditions depending on the set mode and the level.

	Level	Switching status	Control lamp Yellow - coverage	Control lamp Green - voltage indication	Control lamp Red - fault signal
Max. mode of operation		closed	○		○
Max. mode of operation		open			○
Min. mode of operation		closed			○
Min. mode of operation		open	○		○
Fault	any	open	any		



## 7 Maintenance and fault rectification

### 7.1 Maintenance

**Maintenance**

If the device is used properly, no special maintenance is required in normal operation.

**Cleaning**

The cleaning helps that the type label and markings on the instrument are visible.

Take note of the following:

- Use only cleaning agents which do not corrode the housings, type label and seals
- Use only cleaning methods corresponding to the housing protection rating

### 7.2 Rectify faults

**Reaction when malfunction occurs**

The operator of the system is responsible for taking suitable measures to rectify faults.

**Causes of malfunction**

The device offers maximum reliability. Nevertheless, faults can occur during operation. These may be caused by the following, e.g.:

- Sensor
- Process
- Voltage supply
- Signal processing

**Fault rectification**

The first measure to take is to check the output signal. In many cases, the causes can be determined this way and the faults quickly rectified.

**24 hour service hotline**

Should these measures not be successful, please call in urgent cases the VEGA service hotline under the phone no. **+49 1805 858550**.

The hotline is manned 7 days a week round-the-clock. Since we offer this service worldwide, the support is only available in the English language. The service is free, only standard call charges are incurred.

**Checking the switching signal**

Error	Cause	Rectification
Green signal lamp off	Voltage supply interrupted.	Check the voltage supply and the cable connection
	Electronics defective	Exchange the instrument or send it in for repair
Red signal lamp lights (switching output high-impedance)	Error with the electrical connection	Connect the instrument according to the wiring plan
	Shortcircuit or overload	Check the electrical connection

Error	Cause	Rectification
Red signal lamp flashes (switching output high-impedance)	Vibrating frequency out of specification	Check the vibrating element on buildup and remove it
	Buildup on the vibrating element	Check the vibrating element and the sensor if there is buildup and remove it
	Vibrating element damaged	Check if the vibrating element is damaged or extremely corroded

### Reaction after fault rectification

Depending on the reason for the fault and the measures taken, the steps described in chapter "Setup" must be carried out again or must be checked for plausibility and completeness.

### 7.3 How to proceed if a repair is necessary

You can find an instrument return form as well as detailed information about the procedure in the download area of our homepage. By doing this you help us carry out the repair quickly and without having to call back for needed information.

In case of repair, proceed as follows:

- Print and fill out one form per instrument
- Clean the instrument and pack it damage-proof
- Attach the completed form and, if need be, also a safety data sheet outside on the packaging
- Ask the agency serving you to get the address for the return shipment. You can find the agency on our homepage.

## 8 Dismount

### 8.1 Dismounting steps

**Warning:**

Before dismantling, be aware of dangerous process conditions such as e.g. pressure in the vessel, high temperatures, corrosive or toxic products etc.

Take note of chapters "*Mounting*" and "*Connecting to voltage supply*" and carry out the listed steps in reverse order.

### 8.2 Disposal



Pass the instrument on to a specialised recycling company and do not use the municipal collecting points.

Remove any batteries in advance, if they can be removed from the device, and dispose of them separately.

If personal data is stored on the old device to be disposed of, delete it before disposal.

If you have no way to dispose of the old instrument properly, please contact us concerning return and disposal.

## 9 Supplement

### 9.1 Technical data

#### Note for approved instruments

The technical data in the respective safety instructions which are included in delivery are valid for approved instruments (e.g. with Ex approval). These data can differ from the data listed herein, for example regarding the process conditions or the voltage supply.

All approval documents can be downloaded from our homepage.

#### General data

Material 316L corresponds to 1.4404 or 1.4435

##### Materials, wetted parts

- Tuning fork	316L
- Extension tube $\varnothing$ 21 mm (0.84 in)	316L
- Process seal	Klingersil C-4400
- Process fittings	316L

##### Materials, non-wetted parts

- Housing	316L and plastic PEI
- Cable gland	PA, stainless steel, brass
- Sealing, cable gland	NBR
- Blind plug, cable gland	PA

##### M12 x 1 plug connector

- Contact support	PA
- Contacts	CuZn, nickel layer and 0.8 $\mu$ m gold-plated
- Plug seal	FKM

Sensor length (L) 100 ... 1000 mm (3.94 ... 39.37 in)

##### Weight

- Instrument weight (depending on process fitting)	approx. 250 g (0.55 lbs)
- Tube extension	approx. 920 g/m (0.62 lbs/ft)

##### Process fittings

- Pipe thread, cylindrical (DIN 3852-A)	G $\frac{3}{4}$ , G1, R1
- Pipe thread, conical (ASME B1.20.1)	$\frac{3}{4}$ NPT, 1 NPT

##### hygienic fittings

- Clamp (DIN 32676, ISO 2852)	1", 1 $\frac{1}{2}$ ", 2"
- Slotted nut	DN 25 PN 40, DN 40 PN 40, DN 50 PN 25
- SMS	DN 38 PN 6
- Hygienic fitting	F 40 PN 25

##### Max. torque - process fitting

- Thread G $\frac{1}{2}$ , $\frac{1}{2}$ NPT	50 Nm (37 lbf ft)
- Thread G $\frac{3}{4}$ , $\frac{3}{4}$ NPT	75 Nm (55 lbf ft)
- Thread G1, 1 NPT	100 Nm (73 lbf ft)

Surface quality

- Standard  $R_a < 3.2 \mu\text{m}$  (1.26<sup>-4</sup> in)
- Hygienic version  $R_a < 0.8 \mu\text{m}$  (3.15<sup>-5</sup> in)

**Measurement accuracy**

- Hysteresis approx. 2 mm (0.08 in) with vertical mounting
- Switching delay approx. 500 ms (on/off)  
Can be ordered as an option: 0.5 ... 60 s
- Measuring frequency approx. 1100 Hz

**Ambient conditions**

- Ambient temperature on the housing -40 ... +70 °C (-40 ... +158 °F)
- Storage and transport temperature -40 ... +80 °C (-40 ... +176 °F)

**Process conditions**

- Process pressure -1 ... 64 bar/-100 ... 6400 kPa (-14.5 ... 928 psig)
- Process temperature - Standard -40 ... +100 °C (-40 ... +212 °F)

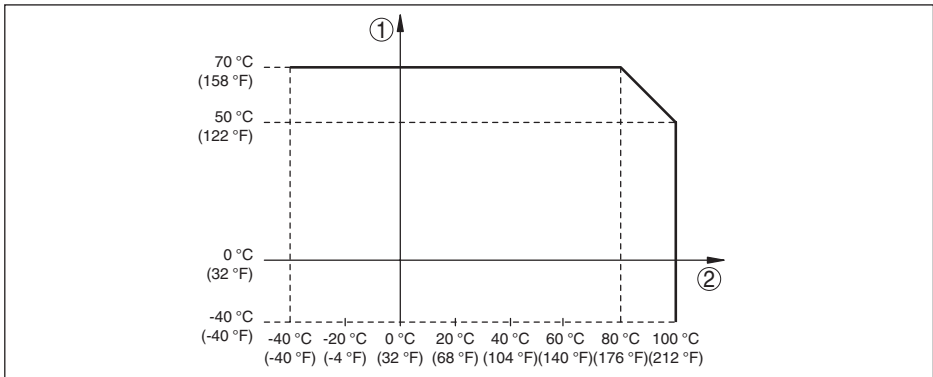

Fig. 11: Dependency ambient temperature to process temperature

- 1 Ambient temperature in °C (°F)
- 2 Process temperature in °C (°F)

Process temperature - High temperature -40 ... +150 °C (-40 ... +302 °F)  
version (option)

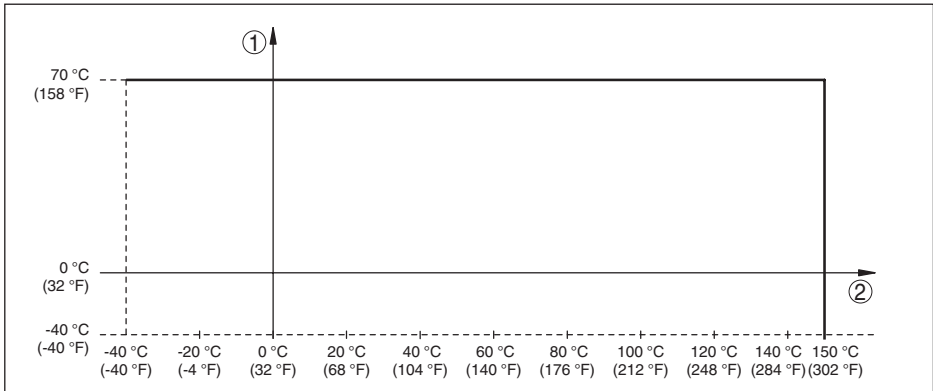

Fig. 12: Dependency ambient temperature to process temperature

- 1 Ambient temperature in °C (°F)  
2 Process temperature in °C (°F)

Viscosity - dynamic	0.1 ... 10000 mPa s
Flow velocity	max. 6 m/s (with a viscosity of 10000 mPa s)
Density	
– Standard sensitivity	0.7 ... 2.5 g/cm <sup>3</sup> (0.025 ... 0.09 lbs/in <sup>3</sup> )
– High sensitivity (can be ordered optionally)	0.5 ... 2.5 g/cm <sup>3</sup> (0.018 ... 0.09 lbs/in <sup>3</sup> )

### Adjustment

Plug connections	Specification see "Connecting to voltage supply"
Signal lamps (LEDs)	
– Green	Voltage supply on
– Yellow	Vibrating element covered
– Red	Fault

### Output variable

Output signal	IO-Link acc. to IEC 61131-9
Connection technology	Three-wire (only with M12 x 1 plug)
Max. cable length to the IO-Link master	20 m
Max. ohmic load ( $R_A$ )	≤ 0.5 kΩ
Switching output	C/Q1: PNP; IO-Link
Switching current C/Q1 (IO-Link)	100 mA
Switching current Q2	250 mA
Switching voltage	≥ operating voltage (L+) -2.7 V DC

### Voltage supply

Operating voltage	9.6 ... 35 V DC
Power consumption	max. 0.5 W

**Electromechanical data**

M12 x 1 plug connector

- Cable Fixed connected to the plug

**Electrical protective measures**

Protection rating

- M12 x 1 plug connection IP66/IP67 acc. to IEC 60529, Type 4X acc. to NEMA or IP68 (0.2 bar) acc. to IEC 60529, Type 6P acc. to NEMA

Overvoltage category

The feeding power supply unit can be connected to networks of overvoltage category III.

Protection class

II

**Approvals**

Instruments with approvals can have different technical specifications depending on the version.

For that reason the associated approval documents of these instruments have to be carefully noted. They are part of the delivery or can be downloaded by entering the serial number of your instrument into the search field under [www.vega.com](http://www.vega.com) as well as in the general download area.

**9.2 Device communication IO-Link**

In the following, the necessary device-specific details are shown. You can find further information of IO-Link on [www.io-link.com](http://www.io-link.com).

**Physical layer**

IO-Link specification: Revision 1.0

SIO mode: Yes

Speed: COM2 38.4 kBaud

Min. cycle time 2.3 ms

Length process data word: 32 Bit

IO-Link Data Storage: Yes

Block parameter adjustment: Yes

**Process data**

The process data of the devices are transmitted cyclically in a data telegram, whereby the process data size is defined by the device. Process data from 0 to 32 bytes are possible for each device (both input and output). The consistency width of the transmission is not fixed and is therefore master-dependent.

Bit 7	Bit 6	Bit 5	Bit 4	Bit 3	Bit 2	Bit 1	Bit 0
-	-	-	-	-	-	-	Q-signal

Q-signal (Bit 0): covered ☑ 1, uncovered ☐ 0

**Device data**

Device data can be parameters, identification data and diagnostic information. They are exchanged acyclically and on request of the IO-Link master. Device data can be written to the device (write) or read from the device (read). For this purpose, the ISDU (Indexed Service Data Unit) was defined

in the IO-Link specification. The ISDU determines, among other things, whether the data is read or written.

### IO-Link specific device data

Designation	ISDU (dez)	ISDU (hex)	Size (Byte)	Data type	Access	Default-Value
VendorName	16	0x0010	max. 64	String	RO	VEGA Grieshaber KG
VendorText	17	0x0011	max. 64	String	RO	www.vega.com
ProductName	18	0x0012	max. 64	String	RO	VEGASWING 51
ProductID	19	0x0013	max. 64	String	RO	SG51.XXXXXXXXXX
ProductText	20	0x0014	max. 64	String	RO	Tuning Fork
Serial Number	21	0x0015	max. 16	String	RO	-
Hardware Revision	22	0x0016	max. 64	String	RO	-
Software version	23	0x0017	max. 64	String	RO	-
Application Specific TAG	24	0x0018	20	String	R/W	Sensor
Process data input	40	0x0028	1	PD In	RO	-

### VEGA-specific device data

Designation	ISDU (dez)	ISDU (hex)	Size (Byte)	Data type	Access	Default-Value	Gradient
Max. frequency value	80	0x50	2	UInt	RW	1180	1
Min. frequency value	81	0x51	2	UInt	RW	523	1
Switching point frequency	82	0x52	2	UInt	RW	969	1
Switch back point frequency	83	0x53	2	UInt	RW	999	1
Switching delay	84	0x54	2	UInt	RW	50	0.01
Reset delay	85	0x55	2	UInt	RW	50	0.01
Delay error output	86	0x56	2	UInt	RW	50	-
Delay after error	87	0x57	2	UInt	RW	50	-
SIO mode	88	0x58	2	UInt	RW	-	-
Temperature	99	0x63	2	Int	RO	-	0.1
Frequency	100	0x64	2	UInt	RO	-	-
Amplitude	101	0x65	2	UInt	RO	-	-
Peak indicator - Min. frequency	150	0x96	2	UInt	RO	-	-
Peak indicator - Max. frequency	151	0x97	2	UInt	RO	-	-
Peak indicator - Min. amplitude	152	0x98	2	UInt	RO	-	-



Designation	ISDU (dez)	ISDU (hex)	Size (Byte)	Data type	Access	Default-Value	Gradient
Peak indicator - Max. amplitude	153	0x99	2	UInt	RO	-	-
Peak indicator - Min. temperature	154	0x9A	2	Int	RO	-	0.1
Peak indicator - Max. temperature	155	0x9B	2	Int	RO	-	0.1

Consider the respective gradient when calculating the correct values.

### System commands

Designation	ISDU (dez)	ISDU (hex)	Access
Restore factory settings	130	82	W

## 9.3 Dimensions

### VEGASWING 53, standard version, threaded fittings

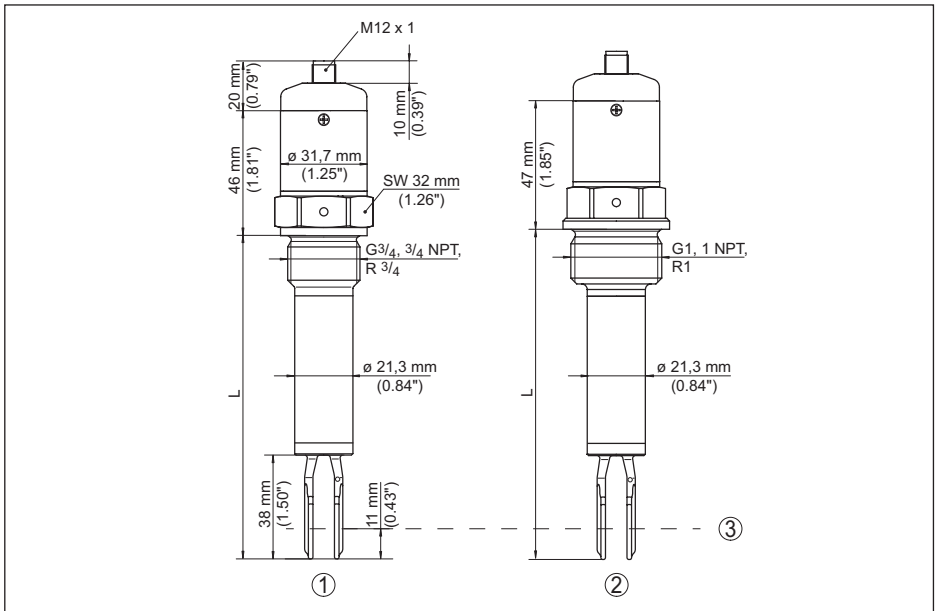

Fig. 13: VEGASWING 53, standard version, threaded fittings

- 1 M12 x 1 plug connection, thread G $\frac{3}{4}$  (DIN ISO 228/1),  $\frac{3}{4}$  NPT
- 2 M12 x 1 plug connection, thread G1 (DIN ISO 228/1), 1 NPT
- 3 Switching point
- L Sensor length

## VEGASWING 53, high temperature versions, threaded fittings

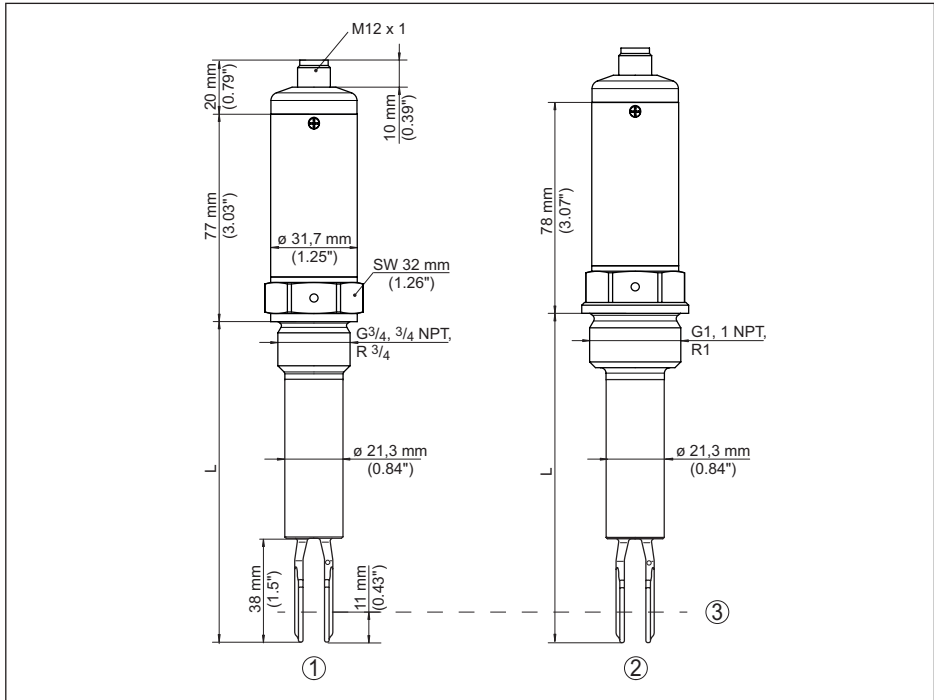

Fig. 14: VEGASWING 53, high temperature versions, threaded fittings

- 1 M12 x 1 plug connection, thread G $\frac{3}{4}$  (DIN ISO 228/1),  $\frac{3}{4}$  NPT
- 2 M12 x 1 plug connection, thread G1 (DIN ISO 228/1), 1 NPT
- 3 Switching point
- L Sensor length

**VEGASWING 53, hygienic versions, hygienic fittings**

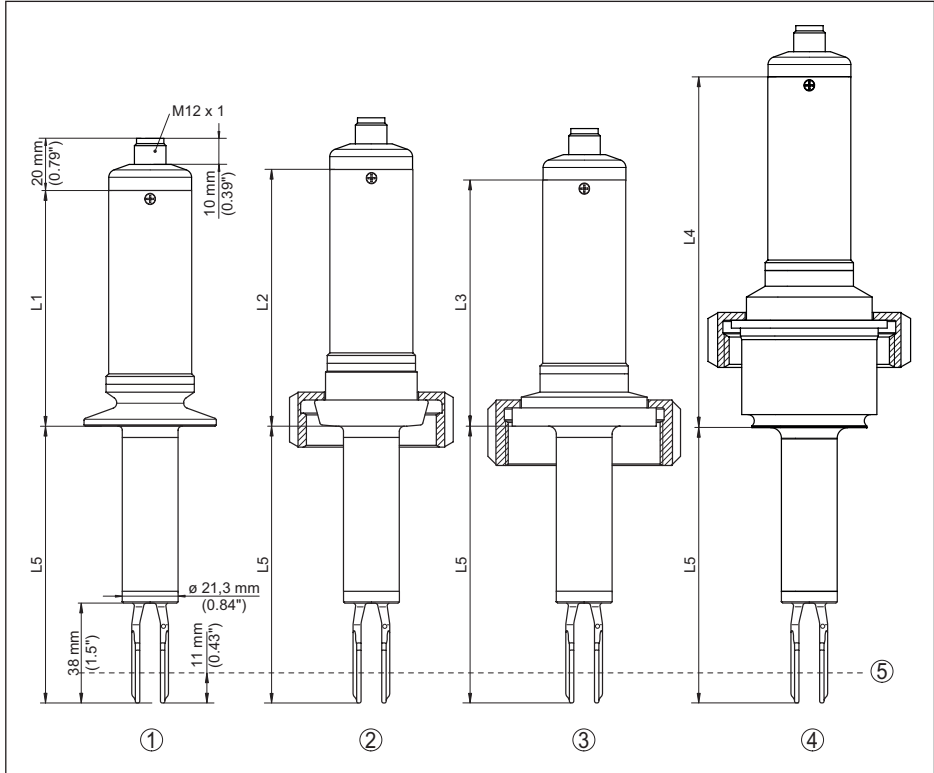

Fig. 15: VEGASWING 53, hygienic versions, hygienic fittings

- 1 M12 x 1 plug connection, Clamp
- 2 M12 x 1 plug connection, slotted nut
- 3 M12 x 1 plug connection, SMS 1145
- 4 M12 x 1 plug connection, hygienic fitting with compression nut
- 5 Switching point
- L1 Clamp 1": 90 mm (3.54 in)  
Clamp 1½": 90 mm (3.54 in)  
Clamp 2": 89 mm (3.50 in)
- L2 Slotted nut DN 25 PN 40: 98 mm (3.86 in)  
Slotted nut DN 40 PN 40: 103 mm (4.06 in)  
Slotted nut DN 50 PN 25: 104 mm (4.09 in)
- L3 SMS fitting: 94 mm (3.70 in)
- L4 Hygienic fitting: 134 mm (5.28 in)

## 9.4 Industrial property rights

VEGA product lines are global protected by industrial property rights. Further information see [www.vega.com](http://www.vega.com).

VEGA Produktfamilien sind weltweit geschützt durch gewerbliche Schutzrechte.

Nähere Informationen unter [www.vega.com](http://www.vega.com).

Les lignes de produits VEGA sont globalement protégées par des droits de propriété intellectuelle. Pour plus d'informations, on pourra se référer au site [www.vega.com](http://www.vega.com).

VEGA líneas de productos están protegidas por los derechos en el campo de la propiedad industrial. Para mayor información revise la pagina web [www.vega.com](http://www.vega.com).

Линии продукции фирмы ВЕГА защищаются по всему миру правами на интеллектуальную собственность. Дальнейшую информацию смотрите на сайте [www.vega.com](http://www.vega.com).

VEGA系列产品在全球享有知识产权保护。

进一步信息请参见网站 < [www.vega.com](http://www.vega.com)。

## 9.5 Trademark

All the brands as well as trade and company names used are property of their lawful proprietor/originator.

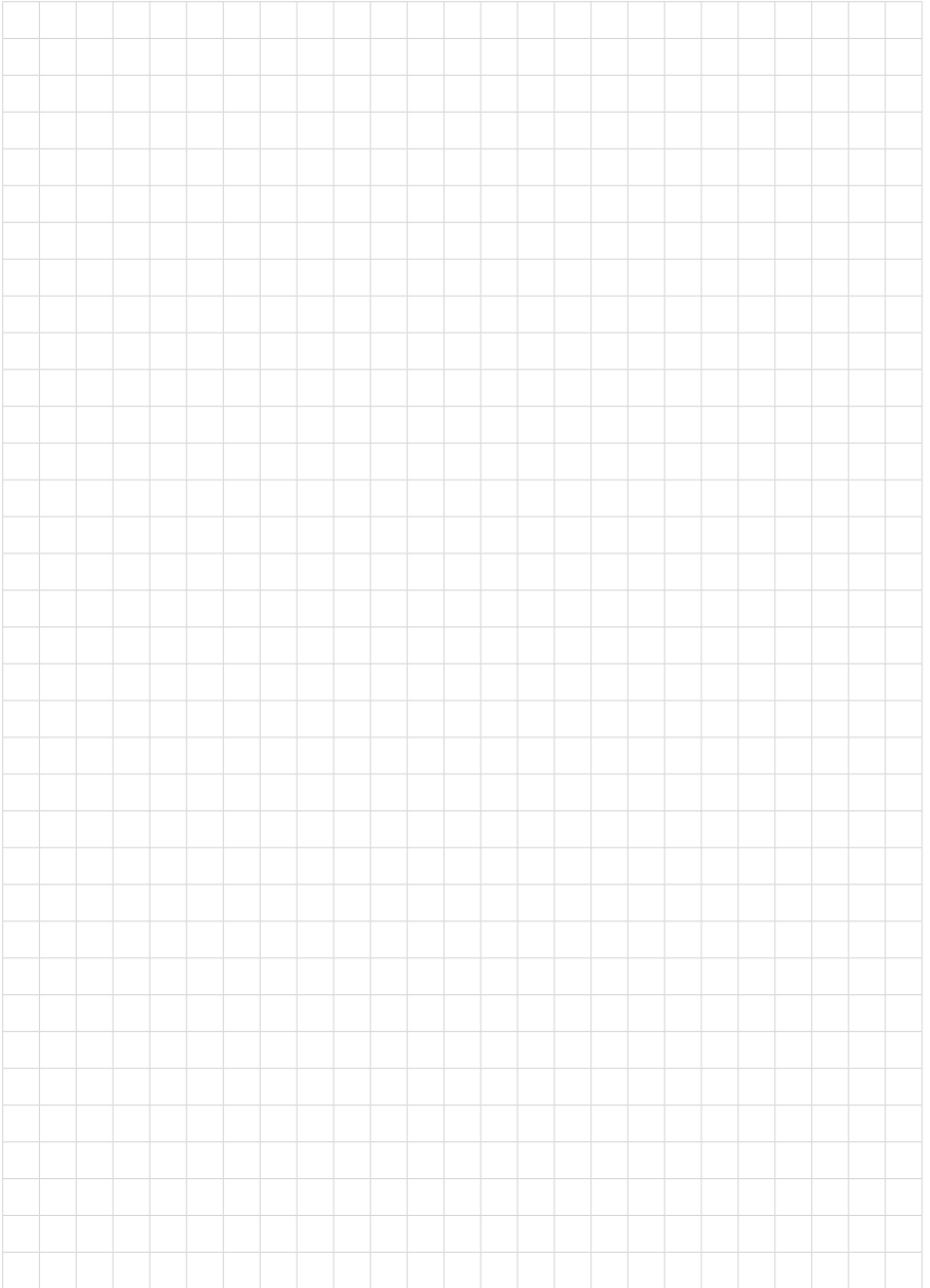





Printing date:

**VEGA**

All statements concerning scope of delivery, application, practical use and operating conditions of the sensors and processing systems correspond to the information available at the time of printing.

Subject to change without prior notice

© VEGA Grieshaber KG, Schiltach/Germany 2023



61863-EN-230208

VEGA Grieshaber KG  
Am Hohenstein 113  
77761 Schiltach  
Germany

Phone +49 7836 50-0  
E-mail: [info.de@vega.com](mailto:info.de@vega.com)  
[www.vega.com](http://www.vega.com)