

Quick setup guide

Radiometric sensor for mass flow detection

WEIGHTRAC 31

Foundation Fieldbus



Document ID: 62089



VEGA

Contents

1	For your safety	3
1.1	Authorised personnel	3
1.2	Appropriate use.....	3
1.3	Warning about incorrect use.....	3
1.4	General safety instructions	3
1.5	Conformity.....	4
1.6	NAMUR recommendations	4
1.7	Installation and operation in the USA and Canada	4
1.8	Environmental instructions	4
2	Product description	6
2.1	Configuration.....	6
2.2	Principle of operation.....	7
2.3	Corresponding source container	7
3	Mounting.....	9
3.1	General instructions	9
3.2	Mounting instructions	10
4	Connecting to power supply.....	20
4.1	Preparing the connection	20
4.2	Connection - Mass flow determination	22
4.3	Connection - Summation.....	24
4.4	Connection - Tachometer	26
5	Adjustment with the display and adjustment module.....	29
5.1	Insert display and adjustment module	29
5.2	Display and adjustment module - Indication of system parameters	29
6	Supplement	31
6.1	Technical data	31



Information:

This quick setup guide enables quick setup and commissioning of your instrument.

You can find supplementary information in the corresponding, more detailed Operating Instructions Manual as well as the Safety Manual that comes with instruments with SIL qualification. These manuals are available on our homepage.

**Operating instructions WEIGHTRAC 31, Foundation Fieldbus:
Document-ID 42375**

Editing status of the quick setup guide: 2022-11-22

1 For your safety

1.1 Authorised personnel

All operations described in this documentation must be carried out only by trained, qualified personnel authorised by the plant operator. During work on and with the device, the required personal protective equipment must always be worn.

1.2 Appropriate use

WEIGHTRAC 31 is a sensor for continuous mass flow detection on conveyor belts as well as screw or chain conveyors.

You can find detailed information about the area of application in chapter "*Product description*".

Operational reliability is ensured only if the instrument is properly used according to the specifications in the operating instructions manual as well as possible supplementary instructions.

1.3 Warning about incorrect use

Inappropriate or incorrect use of this product can give rise to application-specific hazards, e.g. vessel overfill through incorrect mounting or adjustment. Damage to property and persons or environmental contamination can result. Also, the protective characteristics of the instrument can be impaired.

1.4 General safety instructions

This is a state-of-the-art instrument complying with all prevailing regulations and directives. The instrument must only be operated in a technically flawless and reliable condition. The operator is responsible for the trouble-free operation of the instrument. When measuring aggressive or corrosive media that can cause a dangerous situation if the instrument malfunctions, the operator has to implement suitable measures to make sure the instrument is functioning properly.

The safety instructions in this operating instructions manual, the national installation standards as well as the valid safety regulations and accident prevention rules must be observed by the user.

For safety and warranty reasons, any invasive work on the device beyond that described in the operating instructions manual may be carried out only by personnel authorised by the manufacturer. Arbitrary conversions or modifications are explicitly forbidden. For safety reasons, only the accessory specified by the manufacturer must be used.

To avoid any danger, the safety approval markings and safety tips on the device must also be observed.

This measuring system uses gamma rays. Therefore take note of the instructions for radiation protection in chapter "*Product description*". Any work on the source container may only be carried out under the supervision of a qualified radiation protection officer.

1.5 Conformity

The device complies with the legal requirements of the applicable country-specific directives or technical regulations. We confirm conformity with the corresponding labelling.

The corresponding conformity declarations can be found on our homepage.

Electromagnetic compatibility

Instruments with plastic housing are designed for use in an industrial environment. Nevertheless, electromagnetic interference from electrical conductors and radiated emissions must be taken into account, as is usual with class A instruments according to EN 61326-1. If the instrument is used in a different environment, the electromagnetic compatibility to other instruments must be ensured by suitable measures.

1.6 NAMUR recommendations

NAMUR is the automation technology user association in the process industry in Germany. The published NAMUR recommendations are accepted as the standard in field instrumentation.

The device fulfils the requirements of the following NAMUR recommendations:

- NE 21 – Electromagnetic compatibility of equipment
- NE 43 – Signal level for fault information from measuring transducers
- NE 53 – Compatibility of field devices and display/adjustment components
- NE 107 – Self-monitoring and diagnosis of field devices

For further information see www.namur.de.

1.7 Installation and operation in the USA and Canada

This information is only valid for USA and Canada. Hence the following text is only available in the English language.

Installations in the US shall comply with the relevant requirements of the National Electrical Code (ANSI/NFPA 70).

Installations in Canada shall comply with the relevant requirements of the Canadian Electrical Code.

1.8 Environmental instructions

Protection of the environment is one of our most important duties. That is why we have introduced an environment management system with the goal of continuously improving company environmental protection. The environment management system is certified according to DIN EN ISO 14001.

Please help us fulfil this obligation by observing the environmental instructions in this manual:

- Chapter " *Packaging, transport and storage* "

- Chapter " *Disposal* "

2 Product description

2.1 Configuration

Type label

The type label contains the most important data for identification and use of the instrument:

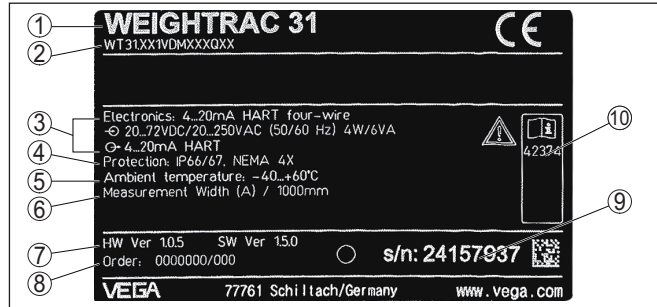

Fig. 1: Layout of the type label (example)

- 1 Instrument type
- 2 Product code
- 3 Electronics
- 4 Protection rating
- 5 Ambient temperature
- 6 Measurement width
- 7 Hardware and software version
- 8 Order number
- 9 Serial number of the instrument
- 10 ID numbers, instrument documentation

Stainless steel type label

Adhesive labels can peel off or become illegible under harsh ambient conditions or the influence of aggressive materials.

The optional stainless steel type label is screwed tightly to the housing and the labelling is permanently resistant.

The stainless steel type label cannot be retrofitted.

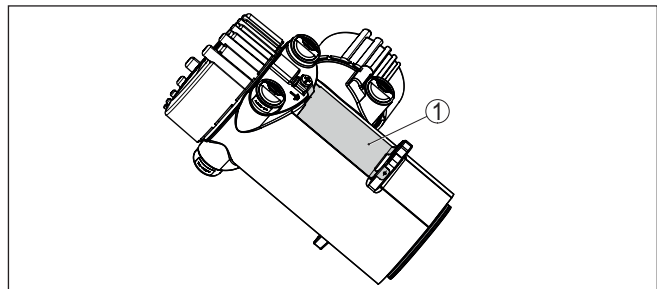

Fig. 2: Position of the stainless steel type label

- 1 Stainless steel type label

Serial number - Instrument search

The type label contains the serial number of the instrument. With it you can find the following instrument data on our homepage:

- Product code (HTML)
- Delivery date (HTML)
- Order-specific instrument features (HTML)
- Operating instructions and quick setup guide at the time of shipment (PDF)
- Test certificate (PDF) - optional

Move to "www.vega.com" and enter in the search field the serial number of your instrument.

Alternatively, you can access the data via your smartphone:

- Download the VEGA Tools app from the "*Apple App Store*" or the "*Google Play Store*"
- Scan the QR-code on the type label of the device or
- Enter the serial number manually in the app

2.2 Principle of operation

Application area

The instrument is suitable for bulk solid applications on conveyor belts and screw conveyors. There are application possibilities in nearly all areas of industry.

Functional principle

In radiometric measurement, a Caesium-137 or Cobalt-60 isotope emits focussed gamma rays that are attenuated when penetrating the conveyor belt and the medium. The PVT detector on the lower side of the conveyor belt receives the radiation, whose strength is proportional to the density. The measuring principle has proven to be very reliable in conjunction with extreme process conditions because it measures contactlessly from outside through the conveyor belt. The measuring system ensures maximum safety, reliability and plant availability, independently of the medium and its properties.

2.3 Corresponding source container

An isotope in a suitable source container (e.g. SHLD-1) is the prerequisite for a radiometric measurement setup.

The handling of radioactive substances is regulated by law. The radiation protection rules of the country in which the system is operated apply first and foremost.

In Germany, for example, the current radiation protection ordinance (StrlSchV) based on the Atomic Energy Law (AtG) applies.

The following points are important for measurement with radiometric methods:

Handling permit

A handling permit is required for operation of a system using gamma rays. This permit is issued by the respective government office or the responsible authority (in Germany, for example, offices for environmental protection, trade supervisory boards, etc.)

You can find further instructions in the operating instructions manual of the source container.

General instructions for radiation protection

When handling radioactive substances, unnecessary radiation exposure must be avoided. An unavoidable radiation exposure must

be kept as low as possible. Take note of the following three important measures:

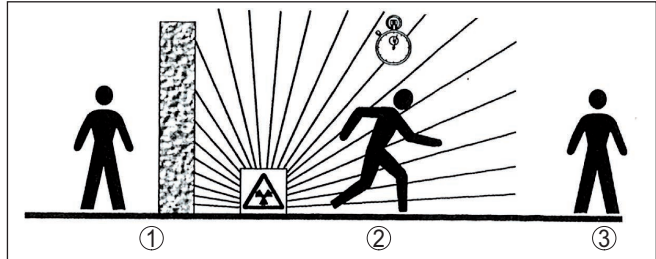

Fig. 3: Measures for protection against radioactive radiation

- 1 Shielding
- 2 Time
- 3 Distance

Shielding: Provide good shielding between the source and yourself as well as all other persons. Special source containers (e.g. SHLD-1) as well as all materials with high density (e.g. lead, iron, concrete, etc.) provide effective shielding.

Time: Stay as short a time as possible in radiation exposed areas.

Distance: Your distance to the source should be as large as possible. The local dose rate of the radiation decreases in proportion to the square of the distance to the radiation source.

Radiation safety officer

The plant operator must appoint a radiation safety officer with the necessary expert knowledge. He is responsible for ensuring that the radiation protection ordinance is complied with and for implementing all radiation protection measures.

Control area

Control areas are areas in which the local dose rate exceeds a certain value. Only persons who undergo official dose monitoring are allowed into these control areas. You can find the respectively valid limit values for control areas in the guideline of the respective authority (in Germany, for example, the radiation protection ordinance).

We are at your disposal for further information concerning radiation protection and regulations in other countries.

3 Mounting

3.1 General instructions

Switch off source

The source container is part of the measuring system. In case the source container is already equipped with an active isotope, the source container must be locked before mounting.



Danger:

Before mounting; make sure that the source is securely closed. Use a padlock to secure the source container in the closed condition and prevent it from being inadvertently opened.

Protection against moisture

Protect your instrument against moisture ingress through the following measures:

- Use a suitable connection cable (see chapter " *Connecting to power supply* ")
- Tighten the cable gland or plug connector
- Lead the connection cable downward in front of the cable entry or plug connector

This applies mainly to outdoor installations, in areas where high humidity is expected (e.g. through cleaning processes) and on cooled or heated vessels.



Note:

Make sure that during installation or maintenance no moisture or dirt can get inside the instrument.

To maintain the housing protection, make sure that the housing lid is closed during operation and locked, if necessary.

Process conditions



Note:

For safety reasons, the instrument must only be operated within the permissible process conditions. You can find detailed information on the process conditions in chapter " *Technical data* " of the operating instructions or on the type label.

Hence make sure before mounting that all parts of the instrument exposed to the process are suitable for the existing process conditions.

These are mainly:

- Active measuring component
- Process fitting
- Process seal

Process conditions in particular are:

- Process pressure
- Process temperature
- Chemical properties of the medium
- Abrasion and mechanical influences

Cable glands**Metric threads**

In the case of instrument housings with metric thread, the cable glands are screwed in at the factory. They are sealed with plastic plugs as transport protection.

You have to remove these plugs before electrical connection.

NPT thread

In the case of instrument housings with self-sealing NPT threads, it is not possible to have the cable entries screwed in at the factory. The free openings for the cable glands are therefore covered with red dust protection caps as transport protection.

Prior to setup you have to replace these protective caps with approved cable glands or close the openings with suitable blind plugs.

The suitable cable glands and blind plugs come with the instrument.

3.2 Mounting instructions**Installation position****Note:**

During the planning, our specialists will analyse the conditions of the measurement loop to dimension the isotope accordingly.

You get a "Source Sizing" document specifying the required source activity and containing all relevant mounting information for your measuring point.

You must follow the instructions in this "Source Sizing" document in addition to the following mounting instructions.

The following mounting information is applicable as long as there is nothing else specified in the "Source Sizing" document.

You can position and mount WEIGHTRAC 31 in the measuring frame from both sides.

Direct the exit angle of the source container to the WEIGHTRAC 31.

Mount the source container at the specified distance to the conveyor belt. Secure the area with a safety fence and protective grating so that no one can reach into the dangerous area.

You can find information on protective barriers and the mounting of the corresponding source container in the operating instructions manual of the source container.

Basic mounting set

If you have ordered WEIGHTRAC 31 without measuring frame, a basic mounting set is enclosed with the instrument.

Determine the mounting position of the sensor in advance.

1. Fasten the mounting bracket (6) to your conveyor belt.

You can either weld the mounting bracket (6) to your system or fasten it with screws through the two $\varnothing 9$ mm (0.35 in) holes.

2. Place two clamp collars (4) onto the premounted mounting brackets (6).

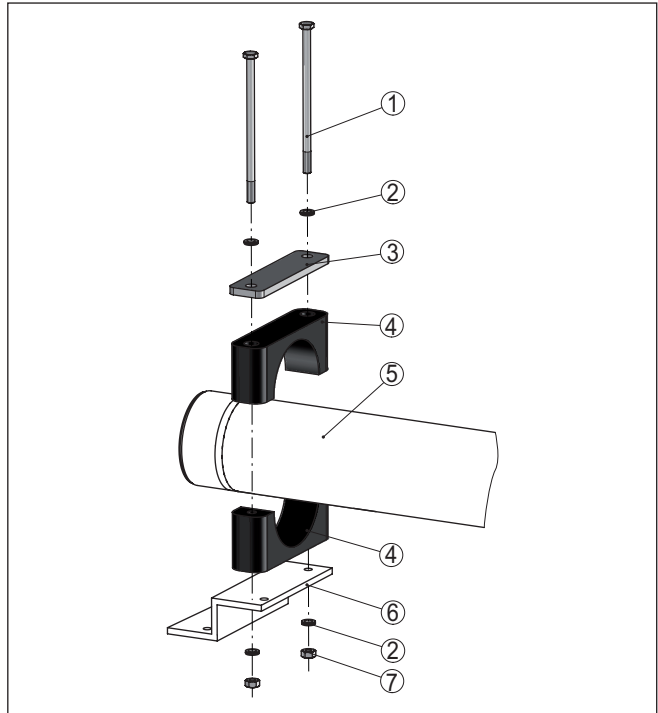

Fig. 4: Mounting of the sensor with the basic mounting set

- 1 Screws M6 x 120 (4 pieces)
- 2 Wedge lock washer M6 Nordlock (8 pieces)
- 3 Cover plate (2 pieces)
- 4 Clamp collar (4 pieces) PA
- 5 Sensor
- 6 Mounting bracket
- 7 Nut M6 (4 pieces)



Note:

Mount the instrument housing of the sensor on an easily accessible side of the conveyor belt so that the instrument is easily accessible for operation and service.

- 3. Move the sensor (5) laterally beneath the conveyor belt and place the sensor in the two clamp collars (4).

Position the measuring width of the sensor below the conveyor belt as close as possible to the center. Make sure that there is sufficient distance between sensor and conveyor belt when the belt is loaded.

- 4. Place the other two clamp collars (4) according to the illustration above the clamp collars that are already in place (4).
- 5. Place a metallic cover plate (3) according to the illustration on each upper clamp collar (4).

6. Insert the screws (1), each with one wedge lock washer (2), through the clamp collars (4).
7. Place a wedge lock washer (2) from below on each screw (1) and screw one nut (7) onto each screw.
8. Align the clamp collars (4) and tighten the nuts (7) evenly with 8 Nm (5.9 lb ft).
9. Check if the sensor (5) is fastened correctly.

Measuring frame (optional)

- Conveyor belts

Mount the measuring frame in such a way that the measurement tube of WEIGHTRAC 31 is below the conveyor belt (tight span).

Keep a distance of at least 10 mm (0.4 in) between the conveyor belt and the measurement tube of WEIGHTRAC 31.

- Screw conveyors

Mount the measuring frame at a position on the spiral conveyor where the product is transported steadily. Avoid places where the product accumulates or falls back over the worm shaft.

- Chain conveyors

When mounting the WEIGHTRAC 31 on a chain conveyor, the installation angle is very important for optimal irradiation.

Follow the instructions in the "Source Sizing" document.

Mounting of the measuring frame (optional)

The measuring frame with mounting accessories can be selected as an option. If you have ordered WEIGHTRAC 31 with measuring frame, then proceed as follows.

Mounting - Crossbeam

Before fastening the support stands, we recommend premounting the measuring frame. By doing this you can easily lay out the holes for fastening the unit to the conveyor belt.

To mount the measuring frame you need a torque wrench (45 Nm or 8 Nm) and two socket wrenches of size 16 and 10.

1. Place the crossbeam (4) on the upper holding fixtures of the two support stands (6).

Make sure that the crossbeam (4) has an excess length of approx. 30 mm on both sides.

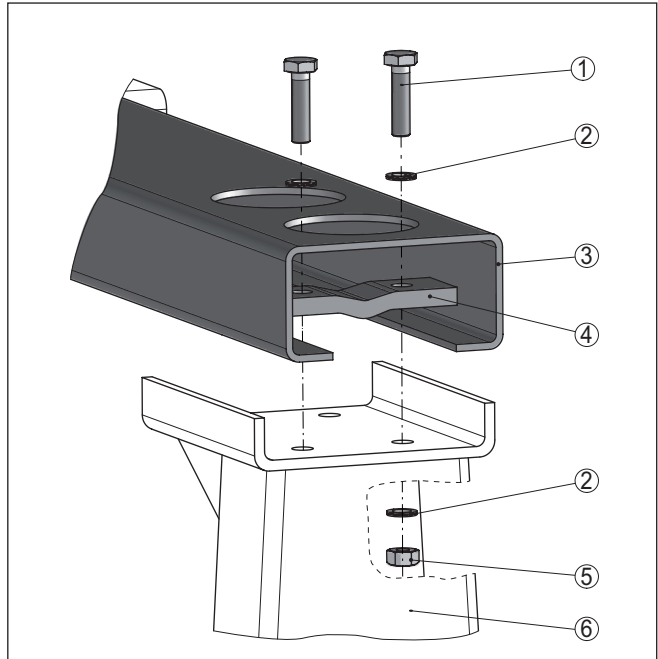

Fig. 5: Mounting the crossbeam

- 1 Screws M10 x 40 (12 pcs.)
- 2 Wedge lock washer M10 Nordlock (24 pieces)
- 3 Crossbeam (1 piece)
- 4 Toe clamps (4 pieces)
- 5 Nut M10 (12 pieces)
- 6 Support stand (2 pieces)

2. Place the four clamping claws (4) with the corrugation downwards into the crossbeam (3).
3. Insert the screws (1) with one wedge lock washer (2) through the clamping claws (4).
4. Place a wedge lock washer (2) from below on each screw (1) and screw one nut (5) onto each screw.
5. Align the crossbeam (3) with the upper holding fixtures of the support stands (6) and tighten the nuts (5) evenly with 45 Nm (33.2 lb ft).

Mounting - Support stand

1. Place the premounted measuring frame above the conveyor belt and determine a suitable position for mounting the support stands (6).

Mount the measuring frame as well centered as possible and at an angle of 90° above the conveyor belt. Keep enough lateral distance to the conveyor belt.

- Drill the through-holes for the support stands (6) according to the following drilling plan.

The through-holes in the support stands (6 in each) are suitable for screws of size M10.

The screws (14) and the washers (15) for fastening on the conveyor belt are not included in the scope of delivery.

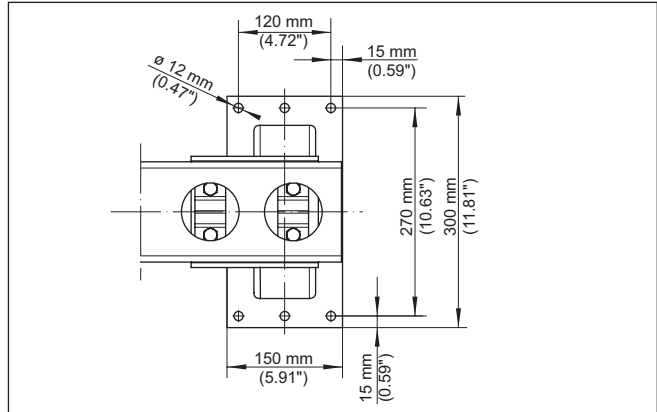

Fig. 6: Drilling plan for support stands

- Use suitable washers (15) for mounting the support stands (6).

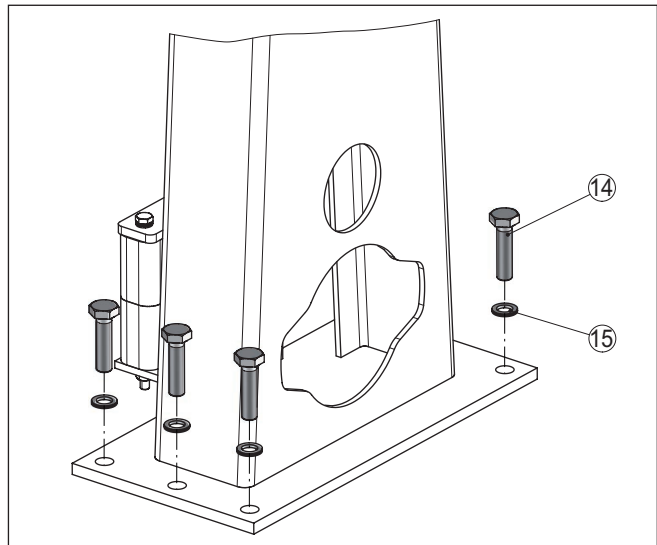

Fig. 7: Mounting the support stands

- 14 Screw M10 (24 pieces) - provided by the customer
 15 Washer M10 (24 pieces) - provided by the customer

- Tighten the screws (14) evenly with 45 Nm (33.2 lb ft).

Mounting - Sensor

1. Place two of the clamp collars (11) on the fastening brackets of the support stands (6).

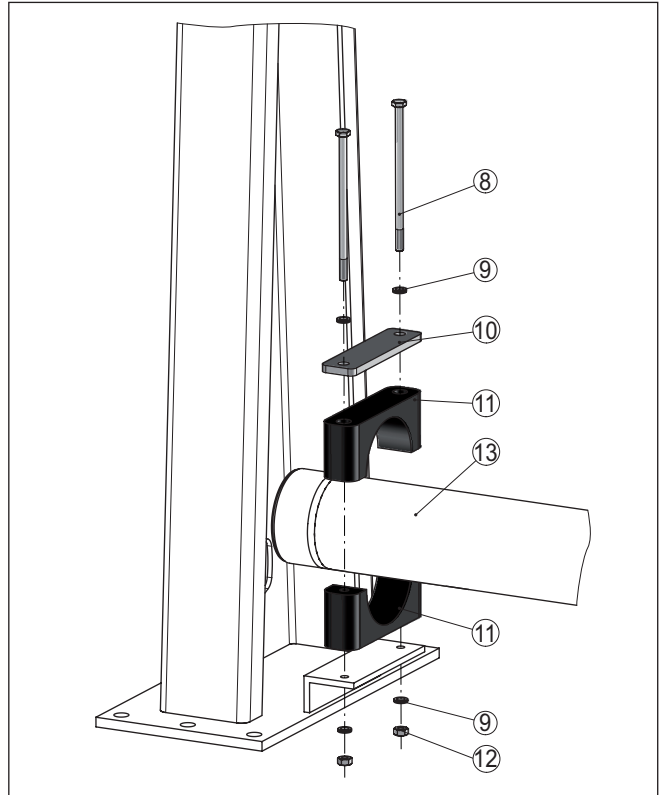

Fig. 8: Mounting the sensor in the measuring frame

- 8 Screws M6 x 120 (4 pieces)
- 9 Wedge lock washer M6 Nordlock (8 pieces)
- 10 Cover plate (2 pieces)
- 11 Clamp collar (4 pieces)
- 12 Nut M6 (4 pieces)
- 13 Sensor



Note:

Mount the instrument housing of the sensor on an easily accessible side of the conveyor belt so that the instrument is easily accessible for operation and service.

2. Insert the sensor (13) laterally into the measuring frame beneath the conveyor belt and place the sensor in the two clamp collars (11).

Position the measuring width of the sensor below the conveyor belt as close as possible to the center. Make sure that there is

sufficient distance between sensor and conveyor belt when the belt is loaded.

3. Place the other two clamp collars (11) according to the illustration above the clamp collars that are already in place (11).
4. Place a metallic cover plate (10) according to the illustration on each upper clamp collar (11).
5. Insert the screws (8), each with one wedge lock washer (9), through the clamp collars (11).
6. Place a wedge lock washer (9) from below on each screw (8) and screw one nut (12) on each of the screws.
7. Align the clamp collars (11) and tighten the nuts (12) evenly with 8 Nm (5.9 lb ft).
8. Check if the sensor (13) is fastened correctly.

Mounting - Source container

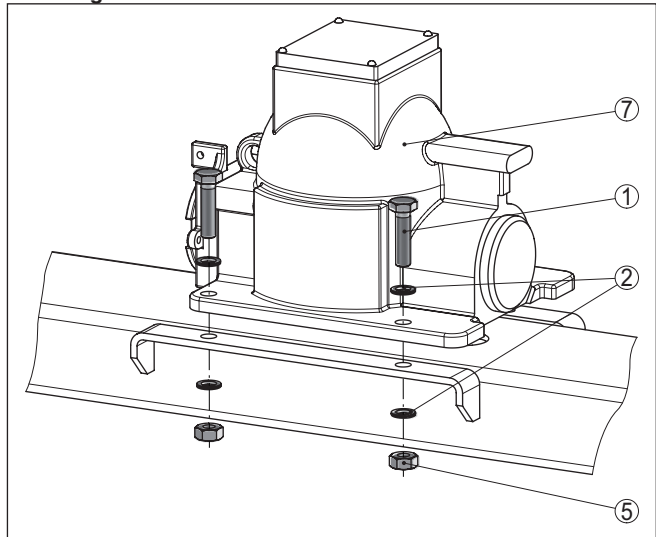

Fig. 9: Mounting the source container on the measuring frame

- 1 Screw M10 x 65 (4 pieces)
- 2 Wedge lock washer M10 Nordlock (8 pieces)
- 5 Nut M10 (4 pieces)
- 7 Source holder (SHLD-1)

1. Place the closed and locked source container (7) from above onto the measuring frame.

The source container is very heavy. Therefore use a suitable lifting device. For this purpose the source container is equipped with a suitable eye-bolt for a lifting hook, etc.



Note:

Select the alignment of the source holder so that the rotary mechanism of the source holder is located on the easily accessible side of the conveyor belt. This makes the rotary mechanism easily accessible

for operation and service at all times. This only applies to source holders with symmetrical beam exit angle.

2. Align the source container (7) with the holes.

Make sure that the source container is placed in the correct direction on the crossbeam.

3. Insert the screws (1) with one wedge lock washer (2) through the flange of the source container (7).
4. Place a wedge lock washer (2) from below on each screw (1) and screw one nut (5) onto each screw.
5. Align the source container (7) and tighten the nuts (5) evenly with 45 Nm (33.2 lb ft).

The mounting of the measuring frame is finished.

Strain the measuring frame

Large measuring frames can deflect when subjected to strong vibration or strong winds.

Therefore, measuring frames used on conveyor belts with widths over 1600 mm (63 in) should be strained with steel cables.

For this there are two fastening straps on the side of the support stand of the measuring frame.

Determine the fastening points on your conveyor belt according to the local conditions.

Provide the straining screws (1) for each cable to ensure reliable straining of the measuring frame.

Make sure that the measuring frame is perfectly vertical after straining.

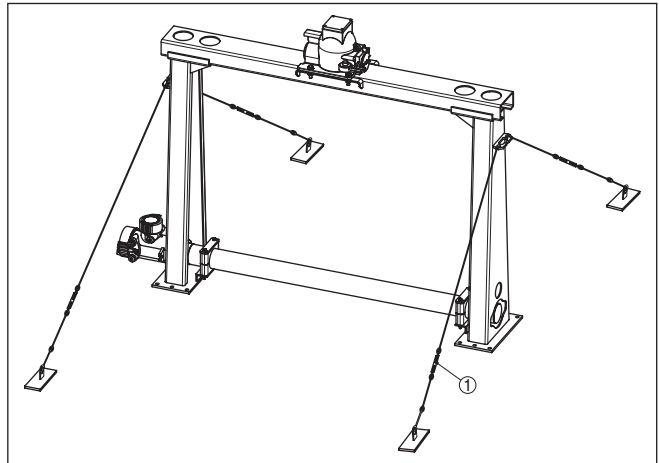

Fig. 10: Straining the measuring frame

1 Straining screw

Protection against heat

If the max. ambient temperature is exceeded, you must take suitable measures to protect the instrument against overheating.

You can protect the instrument by providing a suitable insulation against the heat or mounting the instrument further away from the heat source.

Make sure these measures are taken into account already in the planning stage. If you want to carry out such measures later on, contact our specialists to ensure that the accuracy of the application is not impaired.

If these measures are not sufficient to maintain the max. ambient temperature, you could consider using the water or air cooling system we offer for WEIGHTRAC 31.

The cooling system must also be included in the calculations for the measuring point. Contact our specialists regarding the dimensioning of the cooling.

Mounting of the tachometer

The speed value of the conveyor belt, the conveyor belt is absolutely necessary for mass flow determination.

Apart from other possibilities, a tachometer can be used.

Positioning of the tachometer

Load applied only to one side can cause damage of the tachometer. To avoid this, you should select a position underneath the conveyor belt where the impeller is nearly vertical to the conveyor belt.

The holder of the tachometer is thus premounted to carrier plate with an angle of 115°

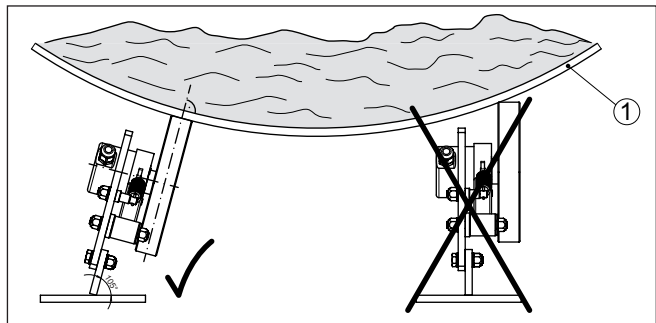

Fig. 11: Impeller of the tachometer, vertically to the conveyor belt

1 Conveyor belt

Direction of rotation

Mount the tachometer according to the following illustration. The correct orientation of the impeller is important. In case of fluctuations, e.g. by alternating load, the impeller can draw aside.

If possible, mount the tachometer close to a support wheel because in these positions the conveyor belt runs evenly.

For height adjustment, the angle bracket of the tachometer is provided with several holes.

Select the height adjustment so that the spring of the impeller is slightly pre-loaded with empty conveyor belt.

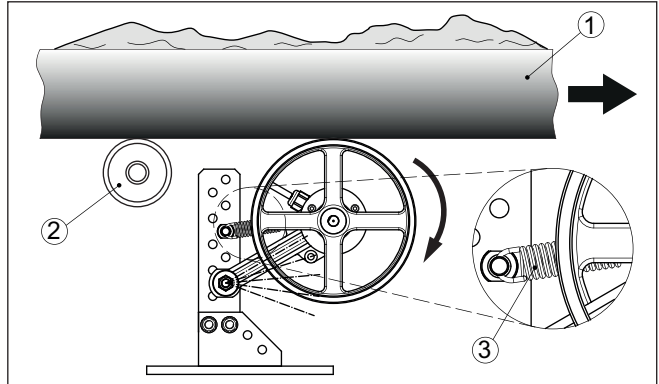

Fig. 12: Direction of rotation of the tachometer

- 1 Conveyor belt
- 2 Support wheel of the conveyor belt
- 3 Spring for pre-loading the impeller

4 Connecting to power supply

4.1 Preparing the connection

Safety instructions

Always keep in mind the following safety instructions:

- The electrical connection must only be carried out by trained, qualified personnel authorised by the plant operator.
- If overvoltage surges are expected, overvoltage arresters should be installed.



Warning:

Only connect or disconnect in de-energized state.



Note:

Install a disconnecting device for the instrument which is easy to access. The disconnecting device must be marked for the instrument (IEC/EN 61010).

Connection technology

The voltage supply and signal output are connected via the spring-loaded terminals in the housing.

Connection to the display and adjustment module or to the interface adapter is carried out via contact pins in the housing.

Connection procedure

Proceed as follows:

The procedure applies to instruments without explosion protection.

1. Unscrew the big housing cover
2. Loosen compression nut of the cable gland and remove blind plug
3. Remove approx. 10 cm (4 in) of the cable mantle, strip approx. 1 cm (0.4 in) of insulation from the ends of the individual wires
4. Insert the cable into the sensor through the cable entry

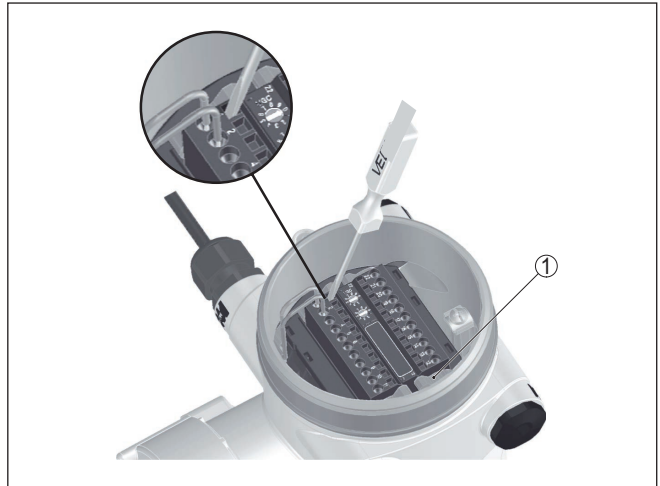

Fig. 13: Connection steps 4 and 5

1 Locking of the terminal blocks

5. Insert a small slotted screwdriver firmly into the rectangular lock openings of the respective connection terminal
6. Insert the wire ends into the round openings of the terminals according to the wiring plan

i **Information:**

Solid cores as well as flexible cores with cable end sleeves are inserted directly into the terminal openings. In case of flexible cores without end sleeves, press the rectangular lock opening with a small screwdriver; the terminal opening is freed. When the screwdriver is released, the terminal opening closes again.

7. Check the hold of the wires in the terminals by lightly pulling on them

To loosen a line, insert a small slotted screwdriver firmly into the rectangular lock opening according to the illustration
8. Connect the shielding to the internal ground terminal, connect the external ground terminal to potential equalisation
9. Tighten the compression nut of the cable entry gland. The seal ring must completely encircle the cable
10. Screw the housing lid back on

The electrical connection is finished.

i **Information:**

The terminal blocks are pluggable and can be detached from the electronics. To do this, loosen the two lateral locking levers of the terminal block with a small screwdriver. When loosening the locking, the terminal block is automatically squeezed out. It must snap in place when re-inserted.

4.2 Connection - Mass flow determination

Non-Ex instruments and instruments with non-intrinsically safe signal output

Electronics and connection compartment - Non-Ex instruments and instruments with non-intrinsically safe signal output

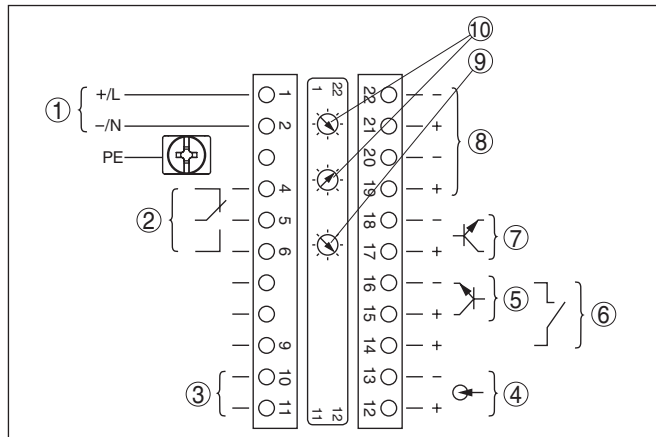

Fig. 14: Electronics and connection compartment with non-Ex instruments and instruments with non-intrinsically safe signal output

- 1 Voltage supply
- 2 Relay output
- 3 Signal output FF bus
- 4 Signal input 4 ... 20 mA (active sensor)
- 5 Switching input for NPN transistor
- 6 Switching input floating
- 7 Transistor output
- 8 Interface for sensor-sensor communication (MGC)
- 9 Simulation switch (1 = simulation on)
- 10 Setting the bus address for sensor-sensor communication (MGC)¹⁾

Adjustment and connection compartment - Non-Ex instruments and instruments with non-intrinsically safe signal output

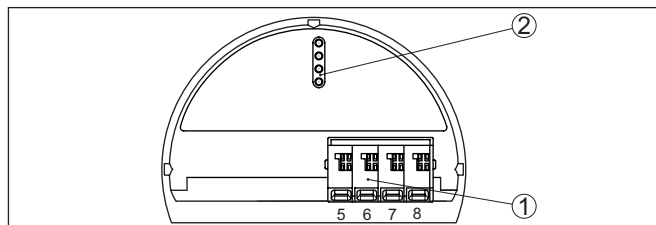

Fig. 15: Adjustment and connection compartment with non-Ex instruments and instruments with non-intrinsically safe signal output

- 1 Terminals for the external display and adjustment unit
- 2 Contact pins for the display and adjustment module or interface adapter

Instruments with intrinsically safe signal output



You can find detailed information on the explosion-protected versions (Ex ia, Ex d) in the Ex-specific safety instructions. These safety

¹⁾ MGC = Multi Gauge Communication

instructions are part of the scope of delivery and come with the Ex-approved instruments.

Electronics and connection compartment - Instruments with intrinsically safe signal output

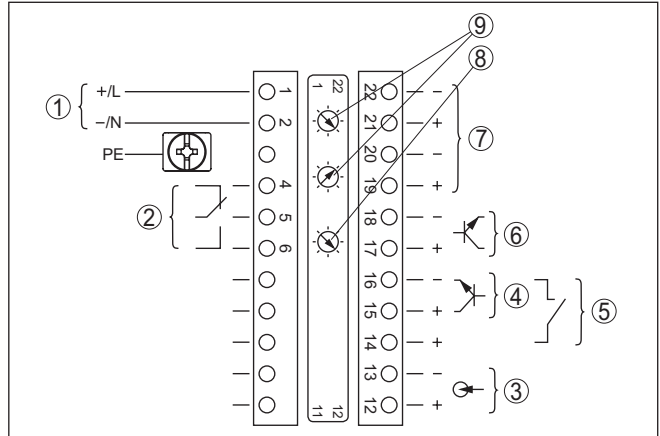

Fig. 16: Electronics and connection compartment (Ex d) with instruments with intrinsically safe signal output

- 1 Voltage supply
- 2 Relay output
- 3 Signal input 4 ... 20 mA (active sensor)
- 4 Switching input for NPN transistor
- 5 Switching input floating
- 6 Transistor output
- 7 Interface for sensor-sensor communication (MGC)
- 8 Simulation switch (1 = simulation on)
- 9 Setting the bus address for sensor-sensor communication (MGC)²⁾

Adjustment and connection compartment - Instruments with intrinsically safe signal output

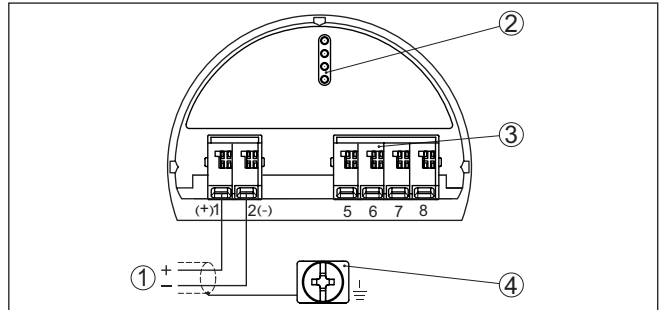

Fig. 17: Adjustment and connection compartment (Ex ia) with instruments with intrinsically safe signal output

- 1 Terminals for intrinsically safe signal output FF bus
- 2 Contact pins for the display and adjustment module or interface adapter
- 3 Terminals for the external display and adjustment unit
- 4 Ground terminal

²⁾ MGC = Multi Gauge Communication

Electronics and connection compartment - summation

4.3 Connection - Summation

Several instruments can be cascaded to measure also broad conveyor belts. The measuring ranges of the instruments must overlap.

Cascading means that two or several instruments are connected which can together cover a longer measuring range.

The instrument acts as Primary and all other instruments operate as Secondaries.

The pulse rates of all instruments are summed in the Primary instrument and converted into a common signal.

The Primary instrument must have the function "Mass flow detection". For this purpose, select under the menu item " *Setup - Application*" the function "Mass flow detection".

Set the address setting (MGC) on the Primary instrument to "99".

For this, the Secondary instruments must be defined as "Summation Secondary". Select under the menu item " *Setup - Application*" the function "Summation Secondary".

The address setting (MGC) on the Secondary instruments can be freely selected. Only the address "99" is reserved for the Primary instrument.

**Note:**

Make sure that all instruments are using the same software version. Software version 2.0 is not downward-compatible.

Connect the instruments according to the following wiring plan:

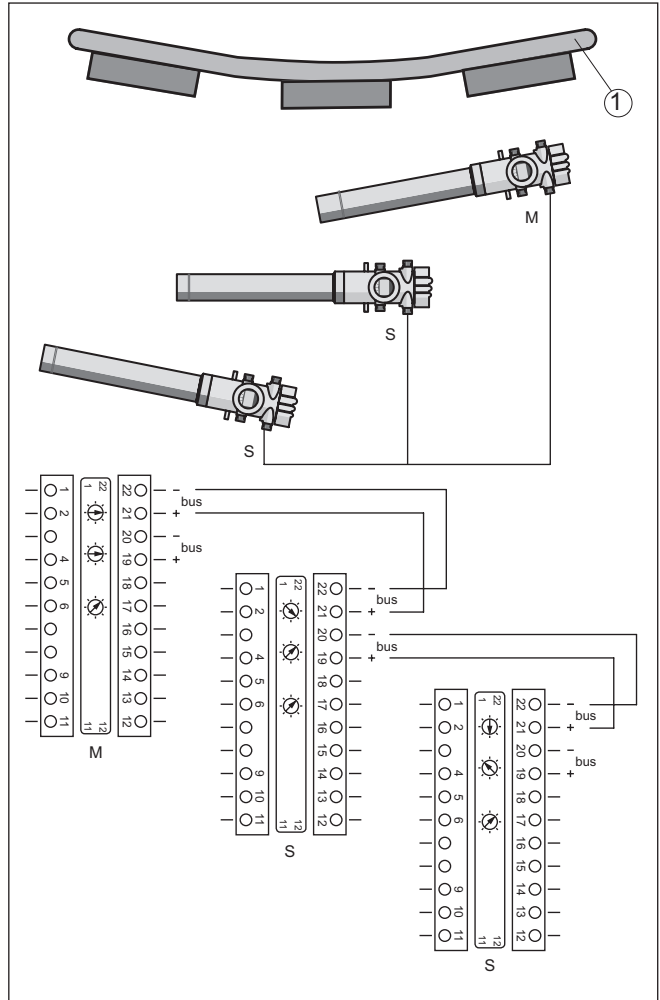

Fig. 18: Electronics and connection compartment with cascading of several instruments.

- 1 Conveyor belt
- M Primary instrument
- S Secondary instrument



Information:

For example, a radial connection would be also possible as an alternative. Take note of the polarity.

The selection of the two terminal pairs is individual.

4.4 Connection - Tachometer

The speed of the conveyor belt, the chain conveyor or the feed screw are absolutely necessary for mass flow determination.

There are three different possibilities:

- Entering a constant speed
- Accepting a speed value from the plant control system (e.g. PLC)
- Connecting a tachometer (analogue or digital)

Constant belt speed

If a constant speed is entered, fluctuations in the speed are not taken into account. This can cause measurement errors. We recommend using a real value from the plant control system or the optional tachometer.

See "*Parameter adjustment - Mass flow detection*".

If you have entered a constant belt speed, we recommend using a belt stop signal.

If the belt stops, measurement is also halted for this period. Without a belt stop signal, WEIGHTRAC 31 would continue summing the delivery rate.

You can implement the belt stop signal with a switching relay or a signal from the plant control system (PLC).

Connect a switching relay to terminals 14 and 16.

Connect the digital output signal (open collector) from the plant control system (PLC) to terminals 14 and 15.

Tachometer (digital)

Digital tachometers enable reliable measurement results through exact detection of the belt speed.

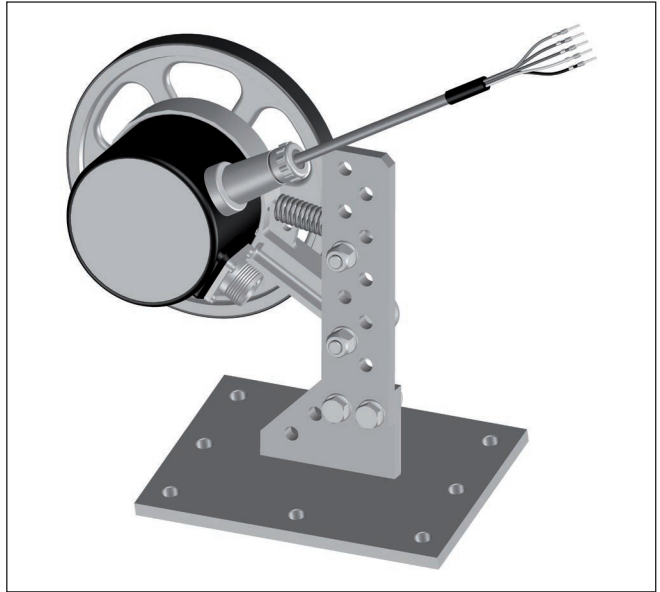

Fig. 19: Digital tachometer

The digital tachometer can be powered by WEIGHTRAC 31. This is only possible if you power WEIGHTRAC 31 with max. 24 V.

Output digital tachometer: Open Collector output

The following cable colours are valid for the fix connected cable.

5 Adjustment with the display and adjustment module

Mount/dismount display and adjustment module

5.1 Insert display and adjustment module

The display and adjustment module can be inserted into the sensor and removed again at any time. It is not necessary to interrupt the voltage supply.

Proceed as follows:

1. Unscrew the small housing cover
2. Place the display and adjustment module in the desired position on the electronics (you can choose any one of four different positions - each displaced by 90°)
3. Press the display and adjustment module onto the electronics and turn it to the right until it snaps in
4. Screw housing lid with inspection window tightly back on

Disassembly is carried out in reverse order.

The display and adjustment module is powered by the sensor, an additional connection is not necessary.

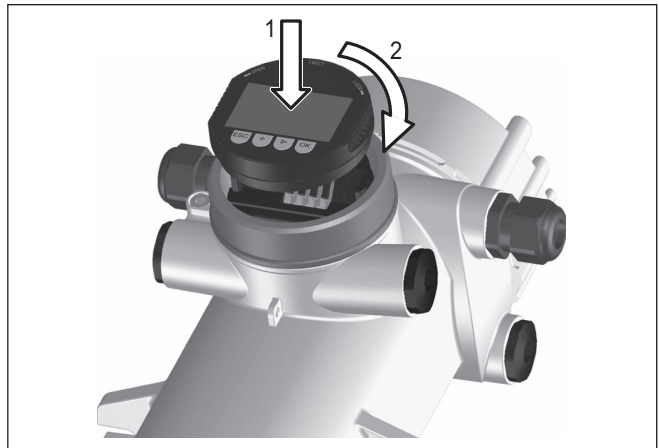

Fig. 21: Insert display and adjustment module



Note:

If you intend to retrofit the instrument with a display and adjustment module for continuous measured value indication, a higher lid with an inspection glass is required.

5.2 Display and adjustment module - Indication of system parameters



Note:

During the first setup or after an instrument reset the instrument starts with an error message (F025 - Invalid linearization table). This is quite

normal because the sensor doesn't yet have any reference points for correct operation. Push the button "OK" to acknowledge the error message. Carry out the adjustment with PACTware.

With the display and adjustment module you can only read out the parameters of the WEIGHTRAC 31. Carry out the parameter adjustment of the instrument with the adjustment software PACTware.

You can find the parameter adjustment in the next chapter.

5.2.1 Setup

Application

In this menu item you can read out the set application.

The application can only be selected in PACTware.

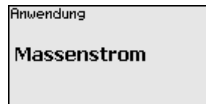

5.2.2 Diagnostics

Device status

In this menu item, you can enquire the status of your sensor. In normal operation, the sensor displays the message "OK". In case of fault, you will find the corresponding fault code here.

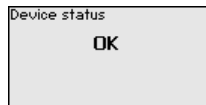

Adjustment data

Here you can retrieve the adjustment value of the sensor. This is the percentage value of the difference of the min. and max. adjustment points (Delta I). The value is an indication for the reliability and non-repeatability of the measurement.

The higher the difference between the two adjustment points, the higher the differential value (Delta I) and the more reliable the measurement. A Delta I value below 10 % is an indication for a critical measurement.

To increase the Delta I value, you have to increase the distance of the min. and max. adjustment points in the linearization.

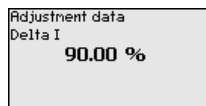

6 Supplement

6.1 Technical data

Note for approved instruments

The technical data in the respective safety instructions which are included in delivery are valid for approved instruments (e.g. with Ex approval). These data can differ from the data listed herein, for example regarding the process conditions or the voltage supply.

All approval documents can be downloaded from our homepage.

Electromechanical data - version IP66/IP67

Options of the cable entry

- Cable entry M20 x 1.5; ½ NPT
- Cable gland M20 x 1.5; ½ NPT (cable diameter see below table)
- Blind plug M20 x 1.5; ½ NPT
- Closing cap ½ NPT

Material cable gland	Material seal insert	Cable diameter				
		4.5 ... 8.5 mm	5 ... 9 mm	6 ... 12 mm	7 ... 12 mm	10 ... 14 mm
PA	NBR	-	●	●	-	●
Brass, nickel-plated	NBR	●	●	●	-	-
Stainless steel	NBR	-	●	●	-	●

Flammability class - Supply lines at least VW-1

Wire cross-section (spring-loaded terminals)

- Massive wire, stranded wire 0.2 ... 2.5 mm² (AWG 24 ... 14)
- Stranded wire with end sleeve 0.2 ... 1.5 mm² (AWG 24 ... 16)

Voltage supply

Operating voltage

- Sensor power supply 24 ... 65 V DC (-15 ... +10 %) or 24 ... 230 V AC (-15 ... +10 %), 50/60 Hz
- FF bus 9 ... 32 V DC

Printing date:

VEGA

All statements concerning scope of delivery, application, practical use and operating conditions of the sensors and processing systems correspond to the information available at the time of printing.

Subject to change without prior notice

© VEGA Grieshaber KG, Schiltach/Germany 2022



62089-EN-221207

VEGA Grieshaber KG
Am Hohenstein 113
77761 Schiltach
Germany

Phone +49 7836 50-0
E-mail: info.de@vega.com
www.vega.com