

Operating Instructions

Capacitive level switch

VEGAPOINT 11

Transistor (PNP)



Document ID: 56622



VEGA

Contents

1	About this document	4
1.1	Function	4
1.2	Target group	4
1.3	Symbols used	4
2	For your safety	5
2.1	Authorised personnel	5
2.2	Appropriate use	5
2.3	Warning about incorrect use	5
2.4	General safety instructions	5
2.5	Installation and operation in the USA and Canada	5
3	Product description	7
3.1	Configuration	7
3.2	Principle of operation	8
3.3	Adjustment	9
3.4	Packaging, transport and storage	9
3.5	Accessories	10
4	Mounting	11
4.1	General instructions	11
4.2	Mounting instructions	12
5	Connecting to power supply	14
5.1	Preparing the connection	14
5.2	Connecting	15
5.3	Wiring plan	15
5.4	Switch-on phase	15
6	Setup	16
6.1	Indication of the switching status	16
6.2	Function table	16
7	Diagnostics and servicing	17
7.1	Maintenance	17
7.2	Rectify faults	17
7.3	Diagnosis, fault messages	17
7.4	How to proceed if a repair is necessary	19
8	Dismount	20
8.1	Dismounting steps	20
8.2	Disposal	20
9	Certificates and approvals	21
9.1	Food and pharmaceutical certificates	21
9.2	Conformity	21
9.3	Environment management system	21
10	Supplement	22
10.1	Technical data	22
10.2	Dimensions	24
10.3	Industrial property rights	26
10.4	Licensing information for open source software	26

10.5 Trademark 26

1 About this document

1.1 Function

This instruction provides all the information you need for mounting, connection and setup as well as important instructions for maintenance, fault rectification, the exchange of parts and the safety of the user. Please read this information before putting the instrument into operation and keep this manual accessible in the immediate vicinity of the device.

1.2 Target group

This operating instructions manual is directed to trained personnel. The contents of this manual must be made available to the qualified personnel and implemented.

1.3 Symbols used



Document ID

This symbol on the front page of this instruction refers to the Document ID. By entering the Document ID on www.vega.com you will reach the document download.



Information, note, tip: This symbol indicates helpful additional information and tips for successful work.



Note: This symbol indicates notes to prevent failures, malfunctions, damage to devices or plants.



Caution: Non-observance of the information marked with this symbol may result in personal injury.



Warning: Non-observance of the information marked with this symbol may result in serious or fatal personal injury.



Danger: Non-observance of the information marked with this symbol results in serious or fatal personal injury.



Ex applications

This symbol indicates special instructions for Ex applications.



List

The dot set in front indicates a list with no implied sequence.



Sequence of actions

Numbers set in front indicate successive steps in a procedure.



Disposal

This symbol indicates special instructions for disposal.

2 For your safety

2.1 Authorised personnel

All operations described in this documentation must be carried out only by trained, qualified personnel authorised by the plant operator.

During work on and with the device, the required personal protective equipment must always be worn.

2.2 Appropriate use

The VEGAPOINT 11 is a sensor for point level detection.

You can find detailed information about the area of application in chapter " *Product description*".

Operational reliability is ensured only if the instrument is properly used according to the specifications in the operating instructions manual as well as possible supplementary instructions.

2.3 Warning about incorrect use

Inappropriate or incorrect use of this product can give rise to application-specific hazards, e.g. vessel overfill through incorrect mounting or adjustment. Damage to property and persons or environmental contamination can result. Also, the protective characteristics of the instrument can be impaired.

2.4 General safety instructions

This is a state-of-the-art instrument complying with all prevailing regulations and directives. The instrument must only be operated in a technically flawless and reliable condition. The operator is responsible for the trouble-free operation of the instrument. When measuring aggressive or corrosive media that can cause a dangerous situation if the instrument malfunctions, the operator has to implement suitable measures to make sure the instrument is functioning properly.

The safety instructions in this operating instructions manual, the national installation standards as well as the valid safety regulations and accident prevention rules must be observed by the user.

For safety and warranty reasons, any invasive work on the device beyond that described in the operating instructions manual may be carried out only by personnel authorised by the manufacturer. Arbitrary conversions or modifications are explicitly forbidden. For safety reasons, only the accessory specified by the manufacturer must be used.

To avoid any danger, the safety approval markings and safety tips on the device must also be observed.

2.5 Installation and operation in the USA and Canada

This information is only valid for USA and Canada. Hence the following text is only available in the English language.

Installations in the US shall comply with the relevant requirements of the National Electrical Code (ANSI/NFPA 70).

Installations in Canada shall comply with the relevant requirements of the Canadian Electrical Code

A Class 2 power supply unit has to be used for the installation in the USA and Canada.

3 Product description

3.1 Configuration

Scope of delivery

The scope of delivery encompasses:

- VEGAPOINT 11 point level switch
- Information sheet " Documents and software" with:
 - Instrument serial number
 - QR code with link for direct scanning



Information:

Optional instrument features are also described in this operating instructions manual. The respective scope of delivery results from the order specification.

Scope of this operating instructions

This operating instructions manual applies to the following instrument versions:

- Hardware version from 1.0.1
- Software version from 1.2.5

Constituent parts

The VEGAPOINT 11 consists of the components:

- Housing with integrated electronics
- Process fitting
- Plug

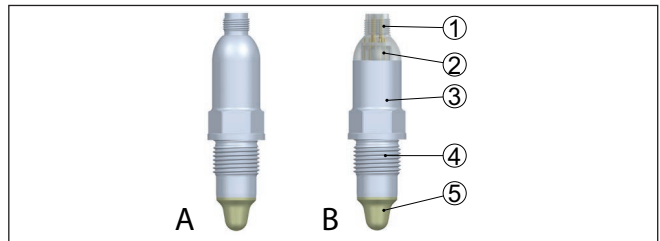

Fig. 1: VEGAPOINT 11

- A Device version with full metal housing 316L
- B Device version with housing 316L and plastic
- 1 Plug connection
- 2 360° status indication
- 3 Instrument housing
- 4 Process fitting
- 5 Sensor

Type label

You will find the type plate on the sensor housing.

The type label contains the most important data for identification and use of the instrument.

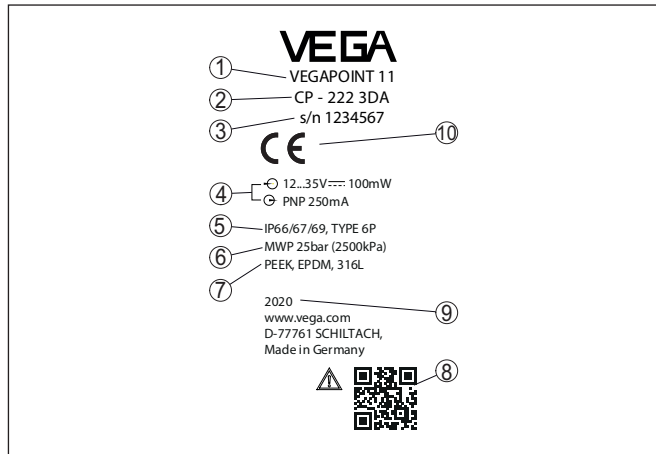

Fig. 2: Layout of the type label (example)

- 1 Order number
- 2 Product name
- 3 Serial number
- 4 Voltage supply and signal output
- 5 Protection rating
- 6 Permissible process pressure
- 7 Material wetted parts
- 8 QR code for device documentation
- 9 Fabrication year
- 10 Approvals

Documents and software Move to "www.vega.com" and enter in the search field the serial number of your instrument.

There you can find the following information about the instrument:

- Order data
- Documentation
- Software

Alternatively, you can find all via your smartphone:

- Scan the QR-code on the type label of the device or
- Enter serial number manually in the VEGA Tools app (available free of charge in the respective stores)

3.2 Principle of operation

Application area

The VEGAPOINT 11 is a capacitive point level sensor for point level detection

It is designed for industrial use in all areas of process technology and can be used in water-based liquids.

Typical applications are overfill and dry run protection. With a the small sensor unit, VEGAPOINT 11 can be also mounted e.g. in thin pipelines. The sensor allows use in vessels, tanks and pipes. Thanks

to its simple and robust measuring system, VEGAPOINT 11 is virtually unaffected by the chemical and physical properties of the medium. It functions even under difficult conditions such as turbulence, air bubbles, buildup, strong external vibration or changing products.

If a malfunction is detected or in case of voltage supply, the electronics takes on a defined switching status, i.e. the output is open (safe state).

Functional principle

An alternating electric field is generated at the tip of the measuring electrode. If the sensor is covered with medium, the resonance frequency changes. This change is detected by the electronics and converted into a switching command.

Buildup is ignored to a certain degree and therefore has no influence on the measurement.

3.3 Adjustment

The switching status of VEGAPOINT 11 can be checked from outside (360° status indication).



Note:

The LED illuminated ring is not available for device versions with full metal housing.

3.4 Packaging, transport and storage

Packaging

Your instrument was protected by packaging during transport. Its capacity to handle normal loads during transport is assured by a test based on ISO 4180.

The packaging consists of environment-friendly, recyclable cardboard. For special versions, PE foam or PE foil is also used. Dispose of the packaging material via specialised recycling companies.

Transport

Transport must be carried out in due consideration of the notes on the transport packaging. Nonobservance of these instructions can cause damage to the device.

Transport inspection

The delivery must be checked for completeness and possible transit damage immediately at receipt. Ascertained transit damage or concealed defects must be appropriately dealt with.

Storage

Up to the time of installation, the packages must be left closed and stored according to the orientation and storage markings on the outside.

Unless otherwise indicated, the packages must be stored only under the following conditions:

- Not in the open
- Dry and dust free
- Not exposed to corrosive media
- Protected against solar radiation
- Avoiding mechanical shock and vibration

Storage and transport temperature

- Storage and transport temperature see chapter " *Supplement - Technical data - Ambient conditions*"
- Relative moisture 20 ... 85 %

3.5 Accessories

The instructions for the listed accessories can be found in the download area on our homepage.

Threaded and hygienic socket

Various threaded and hygienic sockets are available for devices with threaded version.

You can find further information in chapter " *Technical Data*".

4 Mounting

4.1 General instructions

Ambient conditions

The instrument is suitable for standard and extended ambient conditions acc. to DIN/EN/IEC/ANSI/ISA/UL/CSA 61010-1. It can be used indoors as well as outdoors.

Process conditions



Note:

For safety reasons, the instrument must only be operated within the permissible process conditions. You can find detailed information on the process conditions in chapter " *Technical data* " of the operating instructions or on the type label.

Hence make sure before mounting that all parts of the instrument exposed to the process are suitable for the existing process conditions.

These are mainly:

- Active measuring component
- Process fitting
- Process seal

Process conditions in particular are:

- Process pressure
- Process temperature
- Chemical properties of the medium
- Abrasion and mechanical influences

Switching point

The VEGAPOINT 11 can be mounted in any position. The instrument must be mounted in such a way that the sensor is at the height of the requested switching point.

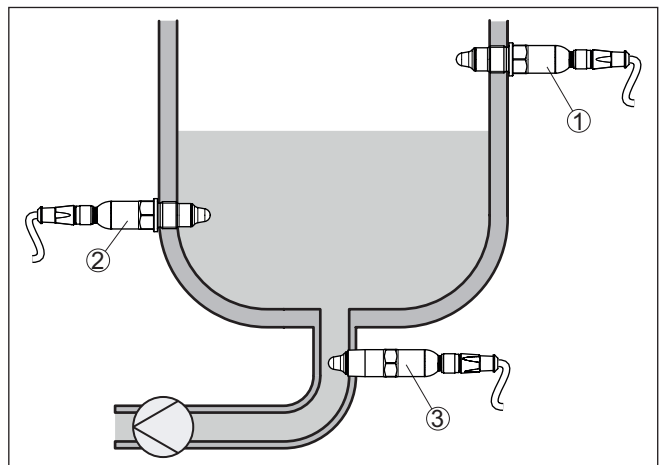

Fig. 3: Installation examples

- 1 Upper level detection (max.) as overflow protection
- 2 Lower level detection (min.) as dry run protection
- 3 Dry run protection (min.) for a pump

Note that the switching point varies depending on the type of medium and the mounting position of the sensor.

Protection against moisture

Protect your instrument against moisture ingress through the following measures:

- Firmly tighten the plug connector
- Lead the connection cable downwards in front of the plug connector

This applies mainly to outdoor installations, in areas where high humidity is expected (e.g. through cleaning processes) and on cooled or heated vessels.

Handling

The level switch is a measuring device for stationary screw mounting and must be treated accordingly. Damage to the measuring tip will destroy the instrument.

Use the hexagon above the thread for screwing in.

After mounting, make sure that the process fitting is screwed in correctly and thus securely seals even at maximum process pressure.

Adhesive products

4.2 Mounting instructions

In adhesive and viscous media, the surfaces of the sensor should protrude into the vessel to avoid buildup. Therefore mounting bosses should not exceed a certain length.

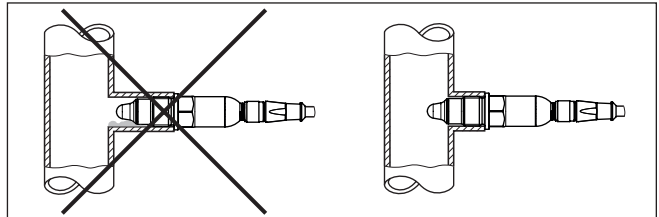

Fig. 4: Adhesive products

In horizontal pipelines, avoid mounting in the upper or lower area of the pipe.

In the upper part of the pipe cavities can form due to air inclusions.

Solids can settle in the lower pipe area. Both can lead to measurement errors.

In horizontal pipelines, lateral installation is therefore recommended.

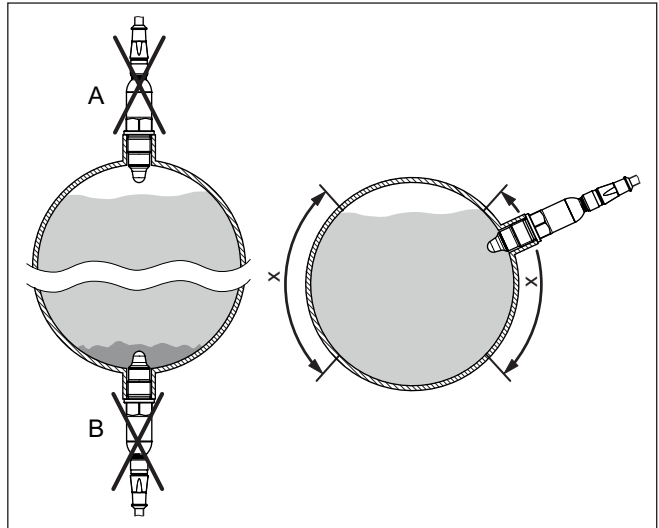

Fig. 5: Installation in horizontal pipelines

x Recommended mounting area

A Not recommended - danger of air inclusions

B Not recommended - Danger of buildup

Inflowing medium

If VEGAPOINT 11 is mounted in the filling stream, unwanted false measurement signals can be generated. For this reason, mount VEGAPOINT 11 at a position in the vessel where no disturbances, e.g. from filling openings, agitators, etc., can occur.

5 Connecting to power supply

5.1 Preparing the connection

Safety instructions

Always keep in mind the following safety instructions:

- Carry out electrical connection by trained, qualified personnel authorised by the plant operator
- If overvoltage surges are expected, overvoltage arresters should be installed



Warning:

Only connect or disconnect in de-energized state.

Voltage supply

The data for power supply are specified in chapter " *Technical data*".



Note:

Power the instrument via an energy-limited circuit (power max. 100 W) acc. to IEC 61010-1, e.g.

- Class 2 power supply unit (acc. to UL1310)
- SELV power supply unit (safety extra-low voltage) with suitable internal or external limitation of the output current

Keep in mind the following additional factors that influence the operating voltage:

- Lower output voltage of the power supply unit under nominal load
- Influence of additional instruments in the circuit (see load values in chapter " *Technical data*")

Connection cable

The instrument is connected with standard four-wire cable. If electromagnetic interference is expected which is above the test values of EN 61326-1 for industrial areas, shielded cable should be used.

Plug connections

Make sure that the cable and the plug used have the required temperature resistance and fire safety for max. occurring ambient temperature.

When mounting outdoors, on cooled vessels or in moist areas in which cleaning is made with steam or high pressure, it is very important that the plug is screwed on correctly.

5.2 Connecting

Instrument versions

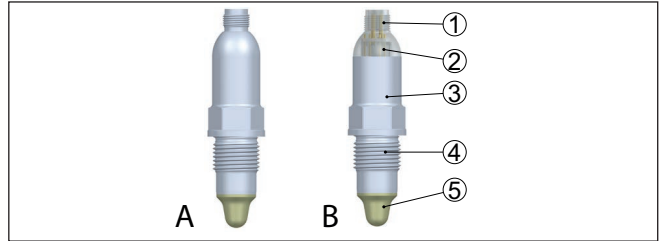

Fig. 6: VEGAPOINT 11 - M12 x 1 plug

- A Device version with full metal housing 316L
- B Device version with housing 316L and plastic
- 1 Plug connection
- 2 360° status indication
- 3 Instrument housing
- 4 Process fitting
- 5 Sensor

M12 x 1 plug connection

This plug connection requires a prefabricated cable with plug. Depending on the version, protection IP66/IP67 or IP69.

5.3 Wiring plan

For connection to binary inputs of a PLC.

M12 x 1 plug

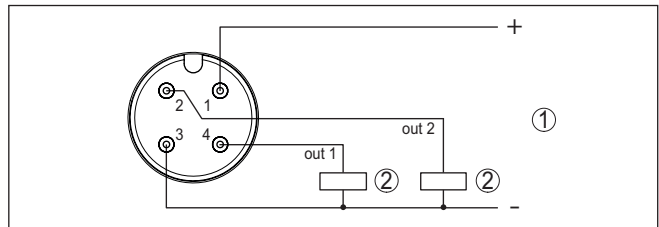

Fig. 7: Wiring plan M12 x 1 plug - Transistor output, three-wire

- 1 Voltage supply
- 2 PNP switching

Contact, plug connector	Function/Polarity
1	Voltage supply/+
2	Transistor output 2
3	Voltage supply/-
4	Transistor output 1

5.4 Switch-on phase

After switching on, the device first carries out a self-check.

The current measured value is then output on the signal cable.

6 Setup

6.1 Indication of the switching status



The switching status of the electronics can be checked via the 360° status indication (LEDs) integrated in the upper part of the housing.

The colours of the 360° status indication have the following meaning:
1)

- Green lights up - power supply connected, sensor output high-impedance
- Green flashing - Maintenance required
- Yellow lights up - power supply connected, sensor output low impedance
- Red lights - shortcircuit or overload in the load circuit (sensor output high-impedance)
- Red flashing - Error at sensor or electronics (sensor output high impedance) or device is in simulation

6.2 Function table

The following table provides an overview of the switching conditions depending on the set mode and the level (factory setting).

Coverage	Switching status ²⁾ Output 1	Switching status ³⁾ Output 2	Control lamp ⁴⁾
Covered 	open	closed	Green
Uncovered 	closed	open	Yellow
Covered/Uncovered	open	open	Red

- 1) Default setting
2) Default setting
3) Default setting
4) Output 1

7 Diagnostics and servicing

7.1 Maintenance

Maintenance

If the device is used properly, no special maintenance is required in normal operation.

Cleaning

The cleaning helps that the type label and markings on the instrument are visible.

Take note of the following:

- Use only cleaning agents which do not corrode the housings, type label and seals
- Use only cleaning methods corresponding to the housing protection rating

7.2 Rectify faults

Reaction when malfunction occurs

The operator of the system is responsible for taking suitable measures to rectify faults.

Causes of malfunction

The device offers maximum reliability. Nevertheless, faults can occur during operation. These may be caused by the following, e.g.:

- Sensor
- Process
- Voltage supply
- Signal processing

Fault rectification

The first measure to take is to check the output signal. In many cases, the causes can be determined this way and the faults quickly rectified.

Reaction after fault rectification

Depending on the reason for the fault and the measures taken, the steps described in chapter " *Setup* " must be carried out again or must be checked for plausibility and completeness.

24 hour service hotline

Should these measures not be successful, please call in urgent cases the VEGA service hotline under the phone no. **+49 1805 858550**.

The hotline is also available outside normal working hours, seven days a week around the clock.

Since we offer this service worldwide, the support is provided in English. The service itself is free of charge, the only costs involved are the normal call charges.

7.3 Diagnosis, fault messages

Checking the switching signal

The 360° status indication on the device indicates the operating status of the device. At the same time it indicates the switching state of the output. This enables simple on-site diagnosis without the need for tools.

Error	Cause	Rectification
Green signal lamp off	Voltage supply interrupted.	Check voltage supply and cable connection
	Electronics defective	Exchange the instrument or send it in for repair
Green signal lamp flashes	Maintenance required	Carry out maintenance
Red signal lamp lights (switching output high-impedance)	Error with the electrical connection	Connect device according to wiring plan
	Shortcircuit or overload	Check electrical connection
	Measuring tip damaged	Check whether the measuring tip is damaged
Red signal lamp flashes (switching output high-impedance)	Sensor outside the specification	Check sensor adjustment Switching points may be interchanged
	Sensor is in simulation mode	Terminate simulation mode

Error messages



Information:

You can read out the error codes from the IO-Link data.

Under " *Device Status*" (ISDU 36) you can find the status of the device.

Failure/Error		
Red control lamp lights up		
Error	Cause	Rectification
F013	no measured value available	Error in the electronics Restart instrument If the error occurs again, replace the device
F080	General software error	Restart instrument
F105	Measured value is determined	Device is still in the switch-on phase Wait until the device is ready for operation
F111	Switching points interchanged	Repeat sensor adjustment The switching point (SP) must be smaller than the reset point (RP)
F260	Error in the calibration	Repeat device adjustment If the error occurs again, replace the device
F261	Error in the instrument settings	Carry out device reset Reset device to delivery status

Out of specification		
Red signal lamp flashes		
Error	Cause	Rectification
S600	Electronics temperature too high	Error in the electronics Allow device to cool down and restart If the error occurs again, check the ambient temperature

Out of specification		
Red signal lamp flashes		
Error	Cause	Rectification
S604	Overload on output	Switching output overloaded Check electrical connection Reduce switching load

Function check		
Red signal lamp flashes		
Error	Cause	Rectification
C700	Simulation active	Terminate simulation mode

7.4 How to proceed if a repair is necessary

You can find an instrument return form as well as detailed information about the procedure in the download area of our homepage. By doing this you help us carry out the repair quickly and without having to call back for needed information.

Proceed as follows in case of repair:

- Print and fill out one form per instrument
- Clean the instrument and pack it damage-proof
- Attach the completed form and, if need be, also a safety data sheet outside on the packaging
- Ask the agency serving you to get the address for the return shipment. You can find the agency on our homepage.

8 Dismount

8.1 Dismounting steps

To remove the device, carry out the steps in chapters "*Mounting*" and "*Connecting to power supply*" in reverse.



Warning:

When dismantling, pay attention to the process conditions in vessels or pipelines. There is a risk of injury, e.g. due to high pressures or temperatures as well as aggressive or toxic media. Avoid this by taking appropriate protective measures.

8.2 Disposal



Pass the instrument on to a specialised recycling company and do not use the municipal collecting points.

Remove any batteries in advance, if they can be removed from the device, and dispose of them separately.

If personal data is stored on the old device to be disposed of, delete it before disposal.

If you have no way to dispose of the old instrument properly, please contact us concerning return and disposal.

9 Certificates and approvals

9.1 Food and pharmaceutical certificates

Versions for use in the food and pharmaceutical industries are available or in preparation for the device or the device series.

The corresponding certificates can be found on our homepage.

9.2 Conformity

The device complies with the legal requirements of the applicable country-specific directives or technical regulations. We confirm conformity with the corresponding labelling.

The corresponding conformity declarations can be found on our homepage.

Electromagnetic compatibility

The instruments are designed for use in an industrial environment. Nevertheless, electromagnetic interference from electrical conductors and radiated emissions must be taken into account, as is usual with a class A instrument according to EN 61326-1.

When the device is mounted in metal containers or tubes, the interference resistance requirements of IEC/EN 61326 for "Industrial environment" and the NAMUR recommendation EMC (NE21) are met.

If the device is to be used in other environments, the electromagnetic compatibility to other devices must be ensured by suitable measures.

9.3 Environment management system

Protection of the environment is one of our most important duties. That is why we have introduced an environment management system with the goal of continuously improving company environmental protection. The environment management system is certified according to DIN EN ISO 14001.

Help us to meet these requirements and observe the environmental instructions in the chapters "*Packaging, transport and storage*", "*Disposal*" of this operating instructions.

10 Supplement

10.1 Technical data

Note for approved instruments

The technical data in the respective safety instructions which are included in delivery are valid for approved instruments (e.g. with Ex approval). These data can differ from the data listed herein, for example regarding the process conditions or the voltage supply.

All approval documents can be downloaded from our homepage.

Materials and weights

Material 316L corresponds to 1.4404

Materials, wetted parts

- | | |
|----------------------------------|-------------------|
| - Sensor tip | PEEK, polished |
| - Device seal - Standard version | FKM |
| - Device seal - Hygienic version | EPDM |
| - Process seal | Klingersil C-4400 |
| - Process fittings | 316L |

Materials, non-wetted parts

- | | |
|---|--|
| - Housing | 316L and plastic (Polycarbonate) or 316L |
| - Device seal - Hygienic design AC and AM ⁵⁾ | EPDM |

Weight approx. 200 g (0.441 lbs)

General data

Process fittings

- | | |
|--|---------------------|
| - Pipe thread, cylindrical (DIN 3852-A) or ISO 228-1 | G½, G¾, G1 |
| - Pipe thread, conical (ASME B1.20.1) | ½ NPT, ¾ NPT, 1 NPT |
| - Metric fine thread, cylindrical | M24 x 1.5 |

Threaded and hygienic adapter

- | | |
|-----------------------------|---|
| - Standard hygienic adapter | G½, G1 |
| | Other connections via hygiene adapters possible |

Max. torque - process fitting

- | | |
|--------------------|--|
| - Thread G½, ½ NPT | 50 Nm (37 lbf ft) |
| - Thread G¾, ¾ NPT | 75 Nm (55 lbf ft) |
| - Thread G1, 1 NPT | 100 Nm (73 lbf ft) |
| - Hygienic adapter | 20 Nm (15 lbf ft) |
| Surface quality | R _a < 0.76 µm (3.00 ⁻⁵ in) |

Measurement accuracy

Hysteresis approx. 1 mm (0.04 in)

5) not in contact with the medium

Switching delay	approx. 500 ms (on/off) Adjustable: 0.5 ... 60 s
Repetitive accuracy	± 1 mm (± 0.04 in)

Ambient conditions

Ambient temperature on the housing	-40 ... +70 °C (-40 ... +158 °F)
Storage and transport temperature	-40 ... +80 °C (-40 ... +176 °F)

Mechanical environmental conditions

Sinusoidal vibrations	4M8 (5 g) at 4 ... 200 Hz according to EN 60068-2-6 (vibration with resonance)
Impacts	50 g, 2.3 ms according to EN 60068-2-27 (mechanical shock)
Impact resistance	IK05 acc. to IEC 62262

Process conditions

Process pressure	-1 ... 25 bar/-100 ... 2500 kPa (-14.5 ... 363 psig)
Process temperature	-20 ... +100 °C (-4 ... +212 °F)

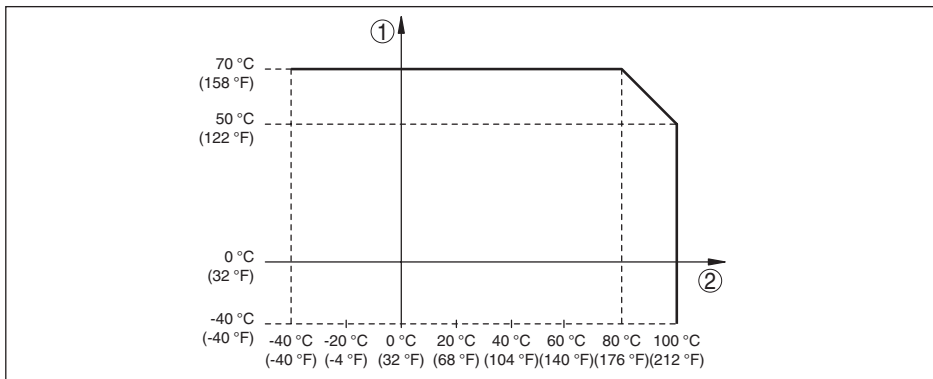

Fig. 8: Dependency ambient temperature to process temperature

- 1 Ambient temperature in °C (°F)
- 2 Process temperature in °C (°F)

SIP process temperature (SIP = Sterilization in place)

Vapour stratification up to 1 h	+135 °C (+275 F)
Dielectric constant	≥ 2.0

Indication (NE 107)

360° status indication (LED)

- Green	Power supply on - Output 1 open
- Yellow	Power supply on - Output 1 closed
- Red	Voltage supply on - failure/simulation

Output variable - Transistor output

Output	Transistor (PNP/NPN)
Load current	max. 250 mA (output, permanently short-circuit proof)
Voltage loss	< 3 V
Switching voltage	< 34 V DC
Blocking current	< 10 μ A

Voltage supply

Operating voltage	12 ... 35 V DC
Max. power consumption	1 W
Reverse voltage protection	Integrated
Max. power consumption	1 W

Electrical protective measures

Potential separation	Electronics potential free up to 500 V AC
Protection rating	

Connection technology	Protection according to EN 60529/IEC 529	Protection according to UL 50
M12 x 1 plug	IP66/IP67/IP69	NEMA 6P

Altitude above sea level	up to 5000 m (16404 ft)
Overvoltage category	I
Protection rating (IEC 61010-1)	III
Pollution degree	4

10.2 Dimensions**VEGAPOINT 11, standard version - thread**

Fig. 9: VEGAPOINT 11, standard version - thread

- 1 Thread G $\frac{1}{2}$, G $\frac{3}{4}$, G1 (DIN ISO 228/1) with M12 x 1 plug connection (Housing: 316L and plastic)
- 2 Thread $\frac{1}{2}$ NPT, $\frac{3}{4}$ NPT, 1 NPT with M12 x 1 plug connection (full metal housing: 316L)

VEGAPOINT 11, hygienic version - Thread

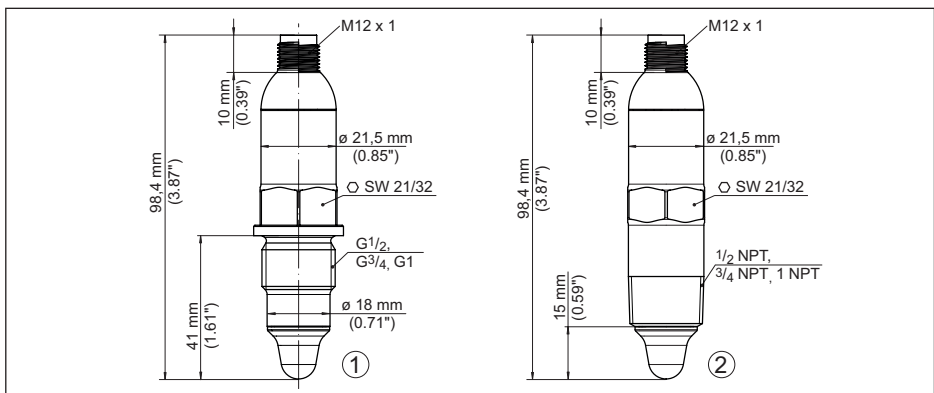
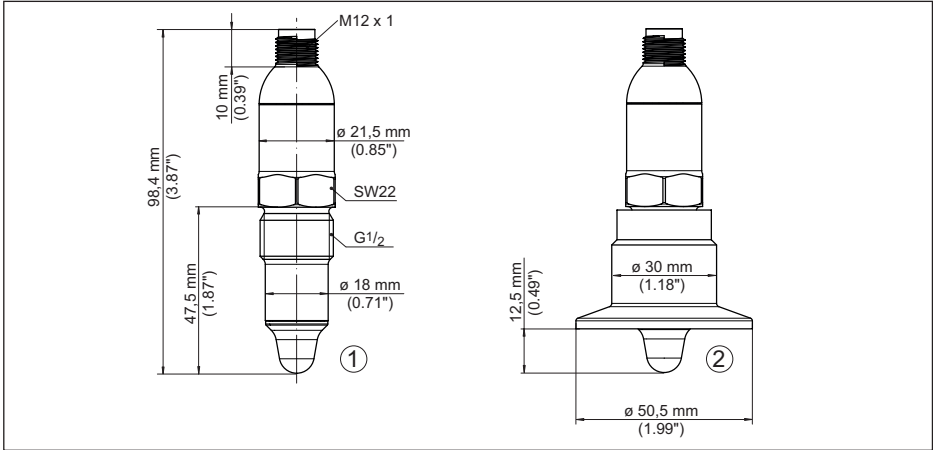

Fig. 10: VEGAPOINT 11, hygienic version - Thread

- 1 Thread G $\frac{1}{2}$ for hygienic threaded adapter (DIN ISO 228/1) with M12 x 1 plug connection
- 2 VEGAPOINT 11, hygienic version in threaded adapter, Clamp

Keep in mind that the total length is extended by the plug connection.

10.3 Industrial property rights

VEGA product lines are global protected by industrial property rights. Further information see www.vega.com.

VEGA Produktfamilien sind weltweit geschützt durch gewerbliche Schutzrechte.

Nähere Informationen unter www.vega.com.

Les lignes de produits VEGA sont globalement protégées par des droits de propriété intellectuelle. Pour plus d'informations, on pourra se référer au site www.vega.com.

VEGA líneas de productos están protegidas por los derechos en el campo de la propiedad industrial. Para mayor información revise la pagina web www.vega.com.

Линии продукции фирмы ВЕГА защищаются по всему миру правами на интеллектуальную собственность. Дальнейшую информацию смотрите на сайте www.vega.com.

VEGA系列产品在全球享有知识产权保护。

进一步信息请参见网站 < www.vega.com。

10.4 Licensing information for open source software

Open source software components are also used in this device. A documentation of these components with the respective license type, the associated license texts, copyright notes and disclaimers can be found on our homepage.

10.5 Trademark

All the brands as well as trade and company names used are property of their lawful proprietor/originator.



Printing date:

VEGA

All statements concerning scope of delivery, application, practical use and operating conditions of the sensors and processing systems correspond to the information available at the time of printing.

Subject to change without prior notice

© VEGA Grieshaber KG, Schiltach/Germany 2022



56622-EN-221012

VEGA Grieshaber KG
Am Hohenstein 113
77761 Schiltach
Germany

Phone +49 7836 50-0
E-mail: info.de@vega.com
www.vega.com