

Safety instructions

VEGACAL 62, 63, 64, 65, 66

Flameproof enclosures

Intrinsic safety

4 ... 20 mA/HART - two-wire

Profibus PA

Foundation Fieldbus



Document ID: 56480



VEGA

Contents

1	Area of applicability.....	3
2	Important specification in the type code.....	3
3	General information.....	4
4	Application area.....	4
5	Specific conditions of use ("X" identification)	5
6	Important information for mounting and maintenance.....	6
7	Safe operating mode	8
8	Instructions for zone 0 applications	8
9	Potential equalization/Grounding	9
10	Electrostatic charging (ESD).....	9
11	Electrical data.....	9
12	Thermal data	10

Supplementary documentation:

- Operating Instructions VEGACAL 62, 63, 64, 65, 66
- 56481 - Certificate of Conformity IECEx TUN 05.0018 X

Editing status: 2017-07-27

1 Area of applicability

These safety instructions apply to the level sensors VEGACAL of type series:

- VEGACAL CL62.DJ***H/P/F****
- VEGACAL CL63.DJ***H/P/F****
- VEGACAL CL64.DJ***H/P/F****
- VEGACAL CL65.DJ***H/P/F****
- VEGACAL CL66.DJ***H/P/F****

with the electronics versions

- H - 4 ... 20 mA/HART - two-wire
- P - Profibus PA
- F - Foundation Fieldbus

according to Certificate of Conformity IECEx TUN 05.0018 X (certificate number on the type label) and for all instruments with safety instruction 56480.

The classification as well as the respective standards are stated in the IECEx Certificate of Conformity:

- IEC 60079-0: 2011, edition 6.0
- IEC 60079-1: 2014, edition 7.0
- IEC 60079-11: 2011, edition 6.0
- IEC 60079-26: 2014, edition 3.0
- Ex ia/db ia IIC T6 ... T1 Ga/Gb
- Ex db ia IIC T6 ... T1 Gb

The above mentioned versions have different approval areas and probably further approvals to ignition protection type Flameproof enclosure "d" and intrinsic safety "i".

These additional certifications for further ignition protection types, different regions and special use are **not** subject of the assessment and evaluation acc. to the Certificate of Conformity IECEx TUN 05.0018 X.

DI - Ex db ia

In the following, all above mentioned versions are called VEGACAL CL62/3/4/5/6. If parts of these safety instructions refer only to certain versions, then these will be mentioned explicitly with their type code.

2 Important specification in the type code

VEGACAL CL6*(*)**.a**abccdefgh

Position	Feature	Description	
a	Approval	DX	ATEX II 1/2G, 2G Ex d ia IIC T6
		DM	ATEX II 1/2G, 2G Ex d ia IIC T6 + Ship approval
		DI	IEC Ex d ia IIC T6
d	Electronics	H	Two-wire 4 ... 20 mA/HART
		P	Two-wire Profibus PA
		F	Two-wire Foundation Fieldbus
e	Housing / Protection	D	Aluminium double chamber / IP 66/IP 68 (0.2 bar)
		Y	Aluminium double chamber / IP 66/IP 67 with M12 x 1 for VEGADIS 61
		W	Stainless steel double chamber / IP 66/IP 68 (0.2 bar)

Position		Feature	Description
f	Cable entry / Cable gland / Plug connection	M	M20 x 1.5 / with / without
		6	M20 x 1.5 / for shielded cable (9 ... 13 mm) with strain relief / without
		7	M20 x 1.5 / approved for cable (6 ... 12 mm) / without
		N	½ NPT / without / without
		8	½ NPT / for shielded cable (9 ... 13 mm) with strain relief / without
		9	½ NPT / approved for cable (6 ... 12 mm) / without
g	Display and adjustment module PLICSCOM	X	without
		A	mounted
		K	mounted; with Bluetooth, magnetic pen operation
		F	without; lid with inspection window
		U	mounted; with Bluetooth (US version), battery, magnetic pen operation

3 General information

The capacitive probes VEGACAL CL62/3/4/5/6 in ignition protection type flameproof enclosure "d" and intrinsic safety "i" are used for gauge measurement of liquids and bulk solids (depending on the type).

The VEGACAL CL62/3/4/5/6 consist of an electronic housing, a probe and process fittings.

The display and adjustment module PLICSCOM can be mounted optionally.

The VEGACAL CL62/3/4/5/6 are suitable for applications in hazardous atmospheres of all combustible materials of explosion groups IIA, IIB and IIC.

The VEGACAL CL62/3/4/5/6 are suitable for applications requiring category 1/2G (EPL Ga/Gb) or 2G (EPL Gb) instruments.

4 Application area

Category 1/2G or 1/3G (EPL Ga/Gb or EPL Ga/Gc instruments)











The VEGACAL CL62/3/4/5/6 with the mechanical fixing element are installed in hazardous areas of zone 1 or zone 2 requiring category 2G (EPL Gb) or 3G (EPL Gc) instruments.

The mechanical fixing element, process connection element is erected as separating wall, separating the areas where instruments of category 2G (EPL Gb) are required.

The sensor measuring system is installed in hazardous areas of zone 0 requiring a category 1G (EPL Ga) instrument.

Category 2G (EPL Gb instruments)

The VEGACAL CL62/3/4/5/6 with the mechanical fixing element are installed in hazardous areas of zone 1 requiring category 2G (EPL Gb) instruments.

VEGA Instrument	3G, EPL Gc	2G, EPL Gb	1/2G, EPL Ga/Gb
			
Ex Zone 2 			
Ex Zone 1 			
Ex Zone 0 			

Note: Sensor image, exemplary

5 Specific conditions of use ("X" identification)

The following overview is listing the properties of VEGACAL CL62/3/4/5/6, which make a labelling with the symbol "X" behind the certificate number necessary.

Ambient temperature

You can find the details in chapter "Thermal data" of these safety instructions.

Impact and friction sparks

The VEGACAL CL62/3/4/5/6 in light metal versions (e.g. aluminium, titanium, zircon) must be mounted in such a way that sparks from impact and friction between light metals and steel (except stainless steel, if the presence of rust particles can be excluded) cannot occur.

The respective parts of the capacitive probes must be effectively secured against swinging and resonating.

When used as Ga/Gb or Ga/Gc instrument

For versions with standard process fittings, the installation must be made in such a way that at least protection rating IP 67 acc. to IEC/EN 60529 is reached on the process fittings.

Electrostatic charging (ESD)

You can find the details in chapter "*Electrostatic charging (ESD)*" of these safety instructions.

Non-grounded, metallic parts

The capacitance of the metal measurement loop label was measured with 15 pF.

VEGACAP CL66 with metal gravity weight: C (gravity weight) = 15 pF

Media resistance

The wetted materials must be resistant against the measured media.

6 Important information for mounting and maintenance

General instructions

The following requirements must be fulfilled for mounting, electrical installation, setup and maintenance of the instrument:

- The staff must be qualified according the respective tasks
- The staff must be trained in explosion protection
- The staff must be familiar with the respectively valid regulations, e.g. planning and installation acc. to IEC/EN 60079-14
- Make sure when working on the instrument (mounting, installation, maintenance) that there is no explosive atmosphere present.
- The instrument has to be mounted according to the manufacturer specifications and the valid regulations and standards
- Modifications on the instrument can influence the explosion protection and hence the safety
- Modifications must only be carried out by authorized employees
- Use only approved spare parts

Cable and wire entries

- The red thread or/dust covers screwed in when the instruments are shipped (depending on the version) must be removed before setup and replaced by cable entries or closing screws suitable for the respective ignition protection type and IP protection.
- Note type and size of the thread: A label with the respective thread name is in the area of the respective thread
- Threads must have no damages
- Cable entries and closing screws should be mounted correctly and according to the safety instructions of the manufacturer to ensure the specified ignition protection type and IP protection rating. When using certified or suitable cable glands, closing screws or plug connections, it is absolutely necessary to note the corresponding certificates/documents. Supplied cable entries or closing screws meet these requirements.
- Unused openings must be closed with plugs suitable for the ignition protection type and IP protection. Supplied plugs meet these requirements.
- Cable or wire entries resp. the closing screws must be tightly screwed into the housing
- The connection cables resp. pipeline sealing facilities must be suitable for the housing temperature range
- The connection cable of VEGACAL CL62/3/4/5/6 has to be wired fix and in such a way that damages can be excluded

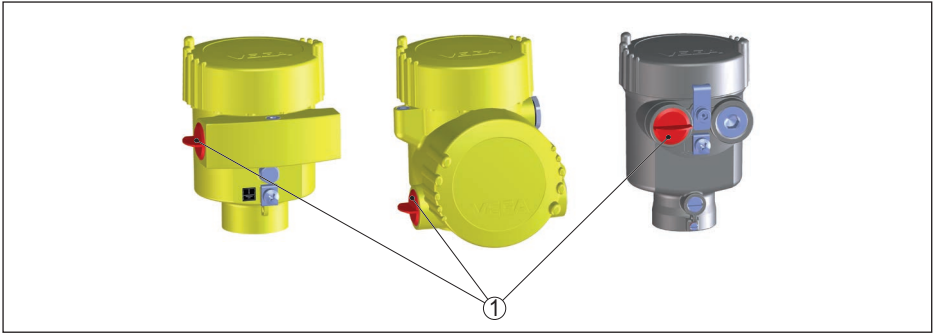

1 Red threaded or dust protection cap

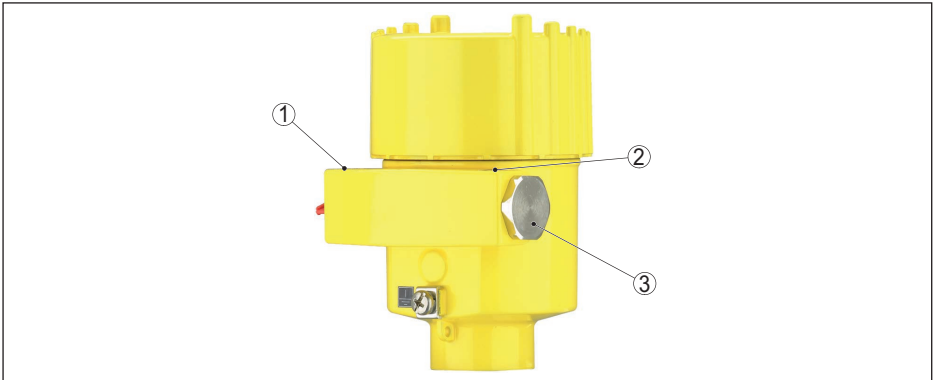

1 Label: Type and size of the thread ½-14 NPT or M20 x 1.5

2 Label: Type and size of the thread ½-14 NPT or M20 x 1.5

3 Screw plug

Mounting

Keep in mind for instrument mounting

- Mechanical damage on the instrument must be avoided
- Mechanical friction must be avoided
- Vessel installations and probable flow must be taken into account
- Close the housing lid (s) up to the stop before starting operating, to ensure the IP protection rating specified on the type label
- Protect the lid against unauthorized opening by unscrewing the locking screw up to the stop. With double chamber housing, you have to protect both lids.
- The instruments must be mounted/installed in such a way that the following can be ruled out:
 - electrostatic charges during operation, maintenance and cleaning.
 - process-related electrostatic charges, e.g. by measuring media flowing past

Maintenance

To ensure the functionality of the device, periodic visual inspection is recommended for:

- Secure mounting
- Mechanical damage or corrosion
- Worn or otherwise damaged cables

- The potential equalization terminal must be secured against loosening
- Correct and clearly marked cable connections

The parts of the VEGACAL CL62/3/4/5/6 being in contact with flammable media during operation must be included in the periodic overpressure test of the plant.

Flameproof enclosure "d"

- The terminals for connecting the operating voltage or signal circuits are integrated in the terminal compartment with ignition protection type flameproof enclosure "d"
- The thread gaps between housing and cover as well as between threaded fitting and container are flameproof joints
- It is not allowed to repair the flameproof joints.
- Cable, wire entries and closing screws must be certified acc. to ignition protection type "Flameproof enclosures Ex-d". Cable, wire entries and closing screws of simple design must not be used.
- Separately certified cable and wire entries can determine the permissible ambient temperature range or the temperature classes
- For connection to a "Conduit" system the corresponding sealing facility must be attached directly to the "Ex-d" connection compartment
- Unused openings must be sealed according to ignition protection type "Flameproof enclosures Ex-d"
- Only one threaded adapter is allowed per thread, when using a closing screw, threaded adapters are not allowed

7 Safe operating mode

General operating conditions

- Do not operate the instrument outside the electrical, thermal and mechanical specifications of the manufacturer
- Use the instrument only in media against which the wetted parts are sufficiently resistant
- Note the relation between process temperature on the sensor/antenna and the permissible ambient temperature on the electronics housing. For permissible temperatures, see the respective temperature tables. See chapter "*Thermal data*".
- If necessary, a suitable overvoltage arrester can be connected in front of the VEGACAL CL62/3/4/5/6
- When used in hybrid mixtures (gas and dust at the same time) additional measures for explosion protection must be taken
- Lids must not be opened if there is a hazardous atmosphere. The housing lids are marked with the warning label:

**WARNING- DO NOT OPEN WHEN AN
EXPLOSIVE ATMOSPHERE IS PRESENT**

8 Instructions for zone 0 applications

In hazardous areas, the instrument should only operated under atmospheric conditions:

- Temperature: -20 ... +60 °C.
- Pressure: 80 ... 110 kPa (0.8 ... 1.1 bar)
- Air with normal oxygen content, normally 21 %

If there are no explosive mixtures or supplementary measures, e.g. according to ISO/EN 1127-1, then the instruments can be also operated according to the manufacturer specifications outside

atmospheric conditions.

If there is a risk of dangerous potential differences inside zone 0, then suitable measures for circuits in zone 0 must be taken, e.g. according to the requirements of IEC/EN 60079-14.

Process fittings between an area requiring category 1G (EP Ga) and less endangered areas must show a tightness in accordance with protection rating IP 67 acc. to IEC/EN 60529.

9 Potential equalization/Grounding

- The instruments with non-galvanically separating barriers P2-2LH and KLEMP2-2LPAFFD must be integrated into the local potential equalisation, e.g. via the internal or external earth terminal
- The potential equalization terminal must be secured against loosening
- If grounding of the cable screening is necessary, this must be carried out acc. to the valid standards and regulations, e.g. acc. to IEC/EN 60079-14
- When using the non-galvanically separating barriers P2-2LH and KLEMP2-2LPAFFD potential equalization must exist in the complete course of the intrinsically safe display and adjustment circuit

10 Electrostatic charging (ESD)

In case of instrument versions with electrostatically chargeable plastic parts, the danger of electrostatic charging and discharging must be taken into account!

The following parts can charge and discharge:

- Lacquered housing version or alternative special lacquering
- Plastic housing
- Metal housing with inspection window
- Plastic process fittings
- Plastic-coated process fittings and/or plastic-coated sensors
- Connection cable for separate versions
- Type label
- Measurement loop identification label

Take note in case of danger of electrostatic charges:

- Avoid friction on the surfaces
- Do not dry clean the surfaces

The instruments must be mounted/installed in such a way that the following can be ruled out:

- electrostatic charges during operation, maintenance and cleaning.
- process-related electrostatic charges, e.g. by measuring media flowing past

The warning label indicates danger:

WARNING- POTENTIAL ELECTROSTATIC CHARGING HAZARD - SEE INSTRUCTIONS

11 Electrical data

VEGACAL CL62-66.DI***H****

Supply and signal circuit: VEGACAL CL62-66.****HD/Y/W*** Terminal 1[+], 2[-] in terminal compartment of the double chamber housing	U = 14 ... 36 V DC U _m = 253 V AC
---	---

VEGACAL CL62-66.DI*P/F*****

Supply and signal circuit: VEGACAL CL62-66.***P/FD/Y/W*** Terminal 1[+], 2[-] in terminal compartment of the double chamber housing	U = 14 ... 32 V DC U _m = 253 V AC
--	---

VEGACAL CL62-66.DI*H/P/F*****

Display and adjustment circuit: VEGACAL CL62-66.***H/P/FD/Y/W*** Terminals 5, 6, 7, 8 in electronics compartment of the double chamber housing	In ignition protection type intrinsic safety Ex ia IIC. Only for connection to the associated VEGA display unit VEGADIS 61/81 according to PTB 02 ATEX 2136X, IECEx PTB 06.0048. The interconnection of the two intrinsically safe circuits was taken into account. Max. values of the connection cable: C _o = 2.4 μF L _o = 160 μH
Display and adjustment circuit: VEGACAL CL62-66.***H/P/FD/Y/W*** Spring contacts in electronics compartment of the double chamber housing	In ignition protection type intrinsic safety Ex ia IIC. Only for connection to the display and adjustment module PLICSCOM.
When using the connection cable supplied by VEGA, the following values must be also taken into consideration:	L _i = 0.62 μH/m C _{i wire/wire} = 150 pF/m C _{i wire/screen} = 270 pF/m

12 Thermal data

Electronics version "H" for category 1/2G (EPL Ga/Gb) instruments

Temperature class	Ambient temperature (Ta)	Product temperature (Tp) on the sensor
T6	-40 ... +46 °C	-20 ... +60 °C
T5	-40 ... +60 °C	
T4		
T3		
T2		
T1		

Electronics version "H" for category 2G (EPL Gb) instruments

Temperature class	Ambient temperature (Ta)	Product temperature (Tp) on the sensor		
		PE insulation	PTFE insulation	PTFE insulation and adapter
T6	-40 ... +46 °C	-40 ... +80 °C	-50 ... +85 °C	-50 ... +85 °C
T5			-50 ... +100 °C	-50 ... +100 °C
T4			-50 ... +135 °C	-50 ... +135 °C
T3			-50 ... +150 °C	-50 ... +200 °C
T2				
T1				

Electronics version "P/F" for category 1/2G (EPL Ga/Gb) instruments

Temperature class	Ambient temperature (Ta)	Product temperature (Tp) on the sensor
T6	-40 ... +38 °C	-20 ... +60 °C
T5	-40 ... +53 °C	
T4	-40 ... +60 °C	
T3		
T2		
T1		

Electronics version "P/F" for category 2G (EPL Gb) instruments

Temperature class	Ambient temperature (Ta)	Product temperature (Tp) on the sensor		
		PE insulation	PTFE insulation	PTFE insulation and adapter
T6	-40 ... +38 °C	-40 ... +80 °C	-50 ... +85 °C	-50 ... +85 °C
T5	-40 ... +53 °C		-50 ... +100 °C	-50 ... +100 °C
T4	-40 ... +60 °C		-50 ... +135 °C	-50 ... +135 °C
T3			-50 ... +150 °C	-50 ... +200 °C
T2				
T1				

Printing date:

VEGA

All statements concerning scope of delivery, application, practical use and operating conditions of the sensors and processing systems correspond to the information available at the time of printing.

Subject to change without prior notice

© VEGA Grieshaber KG, Schiltach/Germany 2017



56480-EN-170818

VEGA Grieshaber KG
Am Hohenstein 113
77761 Schiltach
Germany

Phone +49 7836 50-0
Fax +49 7836 50-201
E-mail: info.de@vega.com
www.vega.com