

Safety instructions

VEGACAL 62, 63, 64, 65, 66

Protection by enclosure

4 ... 20 mA/HART - two-wire

For connection to signal conditioning instrument



CE 0044



Document ID: 55750



VEGA

Contents

1	Area of applicability.....	3
2	Important specification in the type code.....	3
3	General information.....	4
4	Application area.....	4
5	Specific conditions of use ("X" identification)	5
6	Important information for mounting and maintenance.....	5
7	Safe operating mode	7
8	Instructions for zone 0/20 applications	8
9	Potential equalization/Grounding	8
10	Electrostatic charging (ESD)	8
11	Electrical data.....	9
12	Thermal data	10

Supplementary documentation:

- Operating Instructions VEGACAL 62, 63, 64, 65, 66
- 55751 - Certificate of Conformity IECEx TUN 17.0006 X

Editing status: 2017-07-03

1 Area of applicability

These safety instructions apply to the level sensors VEGACAL of type series:

- VEGACAL CL62.GI***H/X****
- VEGACAL CL63.GI***H/X****
- VEGACAL CL64.GI***H/X****
- VEGACAL CL65.GI***H/X****
- VEGACAL CL66.GI***H/X****

with the electronics versions

- H - 4 ... 20 mA/HART - two-wire
- X - for connection to signal conditioning instrument

according to Certificate of Conformity IECEx TUN 17.0006 X (certificate number on the type label) and for all instruments with safety instruction 55750.

The classification as well as the respective standards are stated in the EU type approval certificate:

- IEC 60079-0: 2011
- IEC 60079-11: 2011
- IEC 60079-31: 2013
- Ex ia/tb, ia tb IIIC T65 °C ... T150 °C Da/Db, Db
- Ex ia/tb, ia tb IIIC T65 °C ... T200 °C Da/Db, Db

The above mentioned versions can have further approvals apart from ignition protection type "protection by enclosure t".

These further approvals are **not** subject of the assessment and evaluation acc. to the Certificate of Conformity IECEx TUN 17.0006 X.

VEGACAL CL6*	Approval area			Approvals		
	ATEX	IECEx	Combination ¹⁾	Ex t	+ Ex ia	+ Ex d
GI		x		x		

In the following, all above mentioned versions are called VEGACAL CL62/3/4/5/6. If parts of these safety instructions refer only to certain versions, then these will be mentioned explicitly with their type code.

2 Important specification in the type code

VEGACAL CL6*(*).aabccfgh*

Position		Feature	Description
a	Approval	GI	IEC Ex ia/tb, ia tb IIIC T***°C Da/Db, Db
e	Electronics	H	Two-wire 4 ... 20 mA/HART
		X	For connection to signal conditioning instrument
f	Housing / Protection	A	Aluminium single chamber / IP 66/IP 68 (0.2 bar)
		D	Aluminium double chamber / IP 66/IP 68 (0.2 bar)
		V	Stainless steel single chamber (precision casting) / IP 66/IP 68 (0.2 bar)
		W	Stainless steel double chamber (precision casting) / IP 66/IP 68 (0.2 bar)

¹⁾ Approval area "Combination": Combination of approval Ex ia acc. to ATEX, IECEx, FM and CSA.

Position		Feature	Description
g	Cable entry / Cable gland / Plug connection	M	M20 x 1.5 / with / without
		N	½ NPT / without / without
h	Display and adjustment module PLICSCOM	X	without
		A	mounted
		F	without; lid with inspection window
		B	Laterally mounted
		K	mounted; with Bluetooth, magnetic pen operation
		L	laterally mounted; with Bluetooth, magnetic pen operation
		U	mounted; with Bluetooth (US version), battery, magnetic pen operation
		S	laterally mounted; with Bluetooth (US version), battery, magnetic pen operation

3 General information

The capacitive probes VEGACAL are used for gauge measurement of liquids and bulk solids (depending on the type).

The VEGACAL consist of an electronic housing, a probe and process fittings.

The display and adjustment module PLICSCOM can be mounted optionally.

The VEGACAL are suitable for use in areas with combustible, dust generating bulk solids of group IIIA, IIIB and IIIC. These sensors are suitable for applications requiring category EPL Da/Db or EPL Db instruments.

4 Application area

EPL Da/Db instrument

The electronics housing is installed in hazardous areas of zone 21 requiring EPL Db instruments. The process connection element is installed in the separating wall, which separates areas requiring EPL Db or EPL Da instruments. The probe with the mechanical fixing element is installed in hazardous areas of zone 20 requiring EPL Da instruments.

EPL Db instrument

The electronics housing and the probe with the mechanical fixing element are installed in explosion-endangered areas of zone 21 requiring instruments of EPL Db.

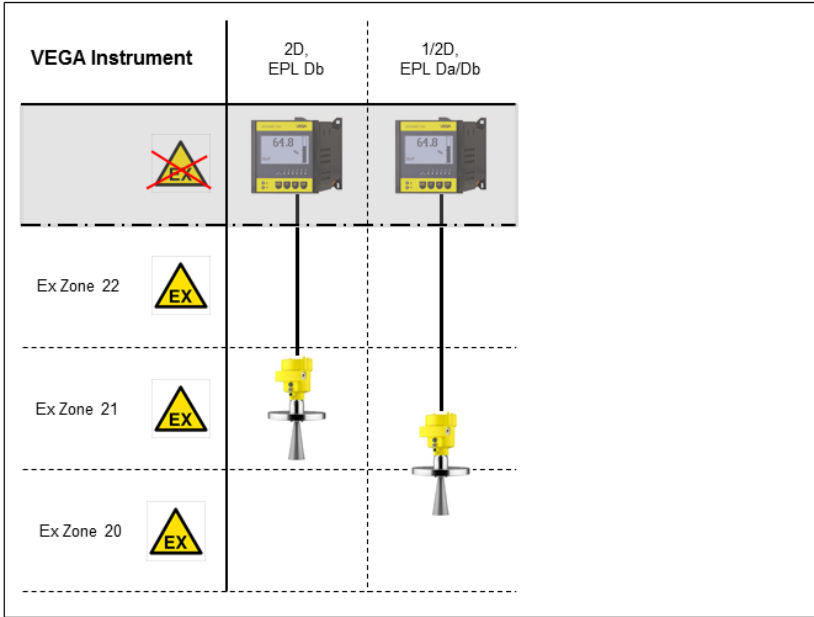

Note: Sensor image, exemplary

5 Specific conditions of use ("X" identification)

The following overview is listing the properties of VEGACAL CL62/3/4/5/6, which make a labelling with the symbol "X" behind the certificate number necessary.

Ambient temperature

You can find the details in chapter "Thermal data" of these safety instructions.

Impact and friction sparks

The VEGACAL CL62/3/4/5/6 in light metal versions (e.g. aluminium, titanium, zircon) must be mounted in such a way that sparks from impact and friction between light metals and steel (except stainless steel, if the presence of rust particles can be excluded) cannot occur.

The respective parts of the capacitive probes must be effectively secured against swinging and resonating.

When used as Da/Db or Da/Dc instrument

For versions with standard process fittings, the installation must be made in such a way that at least protection rating IP 67 acc. to IEC/EN 60529 is reached on the process fittings.

6 Important information for mounting and maintenance

General instructions

The following requirements must be fulfilled for mounting, electrical installation, setup and maintenance of the instrument:

- The staff must qualified according the respective tasks
- The staff must be trained in explosion protection

- The staff must be familiar with the respectively valid regulations, e.g. planning and installation acc. to IEC/EN 60079-14
- Make sure when working on the instrument (mounting, installation, maintenance) that there is no explosive atmosphere present.
- The instrument has to be mounted according to the manufacturer specifications and the valid regulations and standards
- Modifications on the instrument can influence the explosion protection and hence the safety
- Modifications must only be carried out by authorized employees
- Use only approved spare parts

Cable and wire entries

- The red thread or/dust covers screwed in when the instruments are shipped (depending on the version) must be removed before setup and replaced by cable entries or closing screws suitable for the respective ignition protection type and IP protection.
- Note type and size of the thread: A label with the respective thread name is in the area of the respective thread
- Threads must have no damages
- Cable entries and closing screws should be mounted correctly and according to the safety instructions of the manufacturer to ensure the specified ignition protection type and IP protection rating. When using certified or suitable cable glands, closing screws or plug connections, it is absolutely necessary to note the corresponding certificates/documents. Supplied cable entries or closing screws meet these requirements.
- Unused openings must be closed with plugs suitable for the ignition protection type and IP protection. Supplied plugs meet these requirements.
- Cable or wire entries resp. the closing screws must be tightly screwed into the housing
- The connection cables resp. pipeline sealing facilities must be suitable for the housing temperature range
- The connection cable of VEGACAL CL62/3/4/5/6 has to be wired fix and in such a way that damages can be excluded

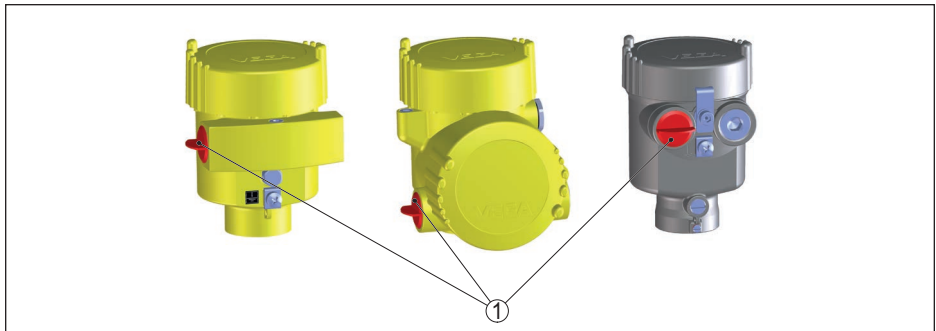

1 Red threaded or dust protection cap

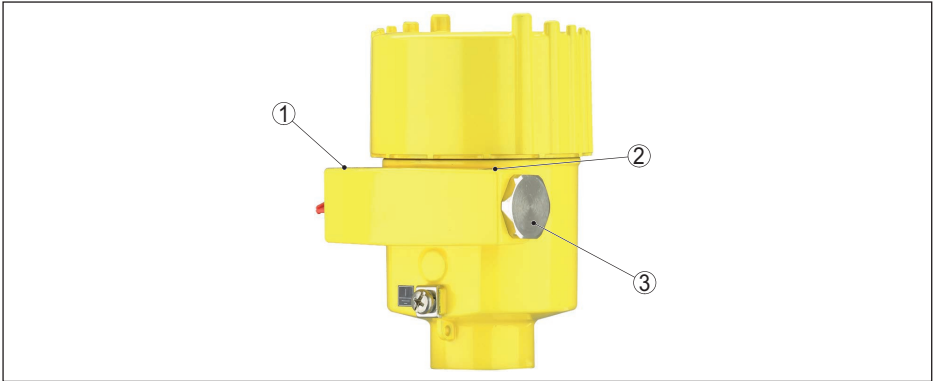

- 1 Label: Type and size of the thread ½-14 NPT or M20 x 1.5
- 2 Label: Type and size of the thread ½-14 NPT or M20 x 1.5
- 3 Screw plug

Mounting

Keep in mind for instrument mounting

- Mechanical damage on the instrument must be avoided
- Mechanical friction must be avoided
- Vessel installations and probable flow must be taken into account
- Close the housing lid (s) up to the stop before starting operating, to ensure the IP protection rating specified on the type label
- Protect the lid against unauthorized opening by unscrewing the locking screw up to the stop. With double chamber housing, you have to protect both lids.
- The instruments must be mounted/installed in such a way that the following can be ruled out:
 - electrostatic charges during operation, maintenance and cleaning.
 - process-related electrostatic charges, e.g. by measuring media flowing past

7 Safe operating mode

General operating conditions

- Do not operate the instrument outside the electrical, thermal and mechanical specifications of the manufacturer
- Use the instrument only in media against which the wetted parts are sufficiently resistant
- Note the relation between process temperature on the sensor/antenna and the permissible ambient temperature on the electronics housing. For permissible temperatures, see the respective temperature tables. See chapter "Thermal data".
- If necessary, a suitable overvoltage arrester can be connected in front of the VEGACAL CL62/3/4/5/6
- Lids must not be opened if there is a hazardous atmosphere. The housing lids are marked with the warning label:

**WARNING- DO NOT OPEN WHEN AN
EXPLOSIVE ATMOSPHERE IS PRESENT**

8 Instructions for zone 0/20 applications

In hazardous areas, the instrument should only be operated under atmospheric conditions:

- Temperature: -20 ... +60 °C.
- Pressure: 80 ... 110 kPa (0.8 ... 1.1 bar)
- Air with normal oxygen content, normally 21 %

If there are no explosive mixtures or supplementary measures, then the instruments can be also operated according to the manufacturer specifications outside atmospheric conditions.

Process fittings between an area requiring EPL Da and less endangered areas must show a tightness in accordance with protection rating IP 67 acc. to IEC/EN 60529.

The operator must ensure that the medium temperature in the EPL Da range within the process vessel is not higher than 80 % of the self-ignition temperature of the concerned medium (in °C) and does not exceed the max. permissible flange temperature depending on the temperature class. The parts of the capacitive probe which during operation are in contact with flammable products, must be integrated in the periodic overpressure test of the plant.

When used as EPL Ga/Gb or EPL Da/Db instrument, a suitable overvoltage arrester must be provided acc. to IEC/EN 60079-14 as protection against overvoltages.

9 Potential equalization/Grounding

- Integrate the instruments into the local potential equalisation, e.g. via the internal or external earth terminal
- If grounding of the cable screening is necessary, this must be carried out acc. to the valid standards and regulations, e.g. acc. to IEC/EN 60079-14
- The intrinsically safe input and the intrinsically safe output circuits are ground-free. The voltage resistance against ground is min. 500 Veff.

10 Electrostatic charging (ESD)

In case of instrument versions with electrostatically chargeable plastic parts, the danger of electrostatic charging and discharging must be taken into account!

The following parts can charge and discharge:

- Lacquered housing version or alternative special lacquering
- Plastic housing
- Metal housing with inspection window
- Plastic process fittings
- Plastic-coated process fittings and/or plastic-coated sensors
- Connection cable for separate versions
- Type label
- Measurement loop identification label

Take note in case of danger of electrostatic charges:

- Avoid friction on the surfaces
- Do not dry clean the surfaces

The instruments must be mounted/installed in such a way that the following can be ruled out:

- electrostatic charges during operation, maintenance and cleaning.
- process-related electrostatic charges, e.g. by measuring media flowing past

The warning label indicates danger:

WARNING- POTENTIAL ELECTROSTATIC CHARGING HAZARD - SEE INSTRUCTIONS

11 Electrical data

VEGACAL CL62-66.GI***X****

<p>Supply and signal circuit: VEGACAL CL62-66.*****XA/V***</p> <p>Terminal 1[+], 2[-] in electronics compartment of the single chamber housing</p> <p>VEGACAL CL62-66.*****XD/W***</p> <p>Terminal 1[+], 2[-] in terminal compartment of the double chamber housing</p>	<p>In ignition protection type intrinsic safety Ex ia IIC.</p> <p>For connection to a certified, intrinsically safe circuit.</p> <p>$U_i = 30\text{ V DC}$</p> <p>$I_i = 131\text{ mA}$</p> <p>$P_i = 983\text{ mW}$</p> <p>$C_i = 3\text{ nF}$</p> <p>$L_i = 5\text{ }\mu\text{H}$ (only with connected electronics PLICSZEKX, otherwise negligible)</p> <p>Characteristics: linear</p>
--	---

VEGACAL CL62-66.GI***H****

<p>Supply and signal circuit: VEGACAL CL62-66.*****HA/V***</p> <p>Terminal 1[+], 2[-] in electronics compartment of the single chamber housing</p> <p>VEGACAL CL62-66.*****HD/W***</p> <p>Terminal 1[+], 2[-] in terminal compartment of the double chamber housing</p>	<p>In ignition protection type intrinsic safety Ex ia IIC.</p> <p>For connection to a certified, intrinsically safe circuit.</p> <p>$U_i = 30\text{ V DC}$</p> <p>$I_i = 131\text{ mA}$</p> <p>$P_i = 983\text{ mW}$</p> <p>C_i negligibly small</p> <p>$L_i = 5\text{ }\mu\text{H}$ (only with connected electronics PLICSZEKX, otherwise negligible)</p> <p>Characteristics: linear</p>
--	--

VEGACAL CL62-66.GI***H/X****

<p>Display and adjustment circuit: VEGACAL CL62-66.*****H/XA/V***</p> <p>Terminals 5, 6, 7, 8 in electronics compartment of the single chamber housing</p> <p>VEGACAL CL62-66.*****H/XD/W***</p> <p>Terminals 5, 6, 7 in terminal compartment of the double chamber housing</p>	<p>In ignition protection type intrinsic safety Ex ia IIC.</p> <p>Only for connection to the associated VEGA display unit VEGADIS 61/81 according to BVS 05 ATEX E 023, IECEx BVS 06.0014.</p>
--	--

<p>Display and adjustment circuit: VEGACAL CL62-66.*****H/XA/V*** Spring contacts in electronics compartment of the single chamber housing</p> <p>VEGACAL CL62-66.*****H/XD/W*** Spring contacts in electronics compartment of the double chamber housing</p>	<p>In ignition protection type intrinsic safety Ex ia IIC. Only for connection to the display and adjustment module PLICSCOM.</p>
<p>When using the connection cable supplied by VEGA, the following values must be also taken into consideration:</p>	<p>$L_i = 0.62 \mu\text{H/m}$ $C_{i \text{ wire/wire}} = 150 \text{ pF/m}$ $C_{i \text{ wire/screen}} = 270 \text{ pF/m}$</p>

12 Thermal data

The following temperature tables apply to all housing and electronic versions and for the use of the VEGACAL CL62/3/4/5/6 as instruments of instrument category 1/2D and 2D.

Version of the probe	Product temperature (Tp) on the sensor	Ambient temperature (Ta)
with PE insulation	-40 ... +80 °C	-40 ... +60 °C
with PTFE insulation	-50 ... +150 °C	-40 ... +60 °C
with PTFE insulation and additional temperature adapter	-50 ... +200 °C	-40 ... +60 °C

For $T_a = 60 \text{ °C}$ and $T_p = 65 \text{ °C}$, the maximum surface temperature of the device is $T_{65 \text{ °C}}$.

For product temperatures above 65 °C , the maximum surface temperature T of the device corresponds to the product temperature T_p .

A large grid of graph paper for taking notes, consisting of 20 columns and 30 rows of small squares.

Printing date:

VEGA

All statements concerning scope of delivery, application, practical use and operating conditions of the sensors and processing systems correspond to the information available at the time of printing.

Subject to change without prior notice

© VEGA Grieshaber KG, Schiltach/Germany 2017



55750-EN-170717

VEGA Grieshaber KG
Am Hohenstein 113
77761 Schiltach
Germany

Phone +49 7836 50-0
Fax +49 7836 50-201
E-mail: info.de@vega.com
www.vega.com