

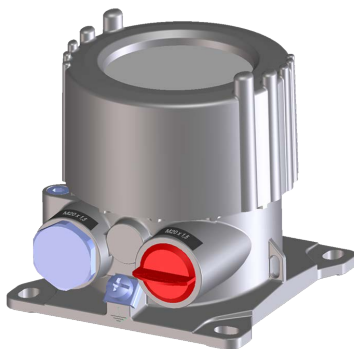

## Safety instructions

### VEGADIS 81

Dust ignition protection by enclosure



CE 0044



Document ID: 55131



**VEGA**

## Contents

<b>1</b>	<b>Area of applicability.....</b>	<b>4</b>
<b>2</b>	<b>Different ignition protection types .....</b>	<b>4</b>
<b>3</b>	<b>Important specification in the type code.....</b>	<b>5</b>
<b>4</b>	<b>General information.....</b>	<b>5</b>
<b>5</b>	<b>Application area.....</b>	<b>6</b>
<b>6</b>	<b>Special operating conditions.....</b>	<b>6</b>
<b>7</b>	<b>Important information for mounting and maintenance.....</b>	<b>6</b>
<b>8</b>	<b>Safe operating mode .....</b>	<b>9</b>
<b>9</b>	<b>Potential equalization/Grounding .....</b>	<b>9</b>
<b>10</b>	<b>Electrostatic charging (ESD) .....</b>	<b>9</b>
<b>11</b>	<b>Electrical data.....</b>	<b>10</b>
<b>12</b>	<b>Thermal data .....</b>	<b>10</b>

Supplementary documentation:

- Operating Instructions VEGADIS 81
- EU type approval certificate BVS 05 ATEX E 023 (Document ID: 55137)
- EU declaration of conformity (Document ID: 43830)

Editing status: 2021-06-21

DE	Sicherheitshinweise für den Einsatz in explosionsgefährdeten Bereichen
EN	Safety instructions for the use in hazardous areas
FR	Consignes de sécurité pour une application en atmosphères explosibles
IT	Normative di sicurezza per l'impiego in luoghi con pericolo di esplosione
ES	Instrucciones de seguridad para el empleo en áreas con riesgo de explosión
PT	Normas de segurança para utilização em zonas sujeitas a explosão
NL	Veiligheidsaanwijzingen voor gebruik op plaatsen waar ontploffingsgevaar kan heersen
SV	Säkerhetsanvisningar för användning i explosionsfarliga områden
DA	Sikkerhedsforskrifter til anvendelse i explosionsfarlig atmosfære
FI	Turvallisuusohjeet räjähdysvaarallisissa tiloissa käyttöä varten
EL	Υποδείξεις ασφαλείας για τη χρησιμοποίηση σε περιοχές που υπάρχει κίνδυνος έκρηξης

DE	Die vorliegenden Sicherheitshinweise sind im Download unter <a href="http://www.vega.com">www.vega.com</a> standardmäßig in den Sprachen deutsch, englisch, französisch und spanisch verfügbar. Weitere EU-Landessprachen stellt VEGA nach Anforderungen zur Verfügung.
EN	These safety instructions are available as a standard feature in the download area under <a href="http://www.vega.com">www.vega.com</a> in the languages German, English, French and Spanish. Further EU languages will be made available by VEGA upon request.
FR	Les présentes consignes de sécurité sont disponibles au téléchargement sous <a href="http://www.vega.com">www.vega.com</a> en standard en allemand, en anglais, en français et en espagnol. VEGA met à disposition d'autres langues de l'Union Européenne selon les exigences.
ES	Las indicaciones de seguridad presentes están disponibles en la zona de descarga de <a href="http://www.vega.com">www.vega.com</a> de forma estándar en los idiomas inglés, francés y español. VEGA pone a disposición otros idiomas de la UE cuando son requeridos.

# 1 Area of applicability

These safety instructions apply to the display and adjustment unit VEGADIS 81 of type series:

- DIS81(\*).AR\*\*\*\*\*
- DIS81(\*).AH\*\*\*\*\*
- DIS81(\*).AJ\*\*\*\*\*

According to EU type approval certificate BVS 05 ATEX E 023 (certificate number on the type label) and for all instruments with safety instruction 55131.

The classification as well as the respective standards are stated in the EU type approval certificate:

- EN IEC 60079-0: 2018
- EN 60079-31: 2014

Type of protection marking:

- II 2D Ex tb IIIC T75°C Db

The above mentioned versions have different approval areas and probably further approvals to ignition protection type "Dust ignition protection by enclosure Ex t".

VEGADIS	Approval area			Approvals		
	ATEX	IECEX	Combination <sup>1)</sup>	Ex t	+ Ex ia	+ Ex db
AR	x			x		
AJ	x			x		x
AH	x			x	x	

Other ignition protection types, the certification for different regions and special use (e.g. ships) are **not** subject of the assessment and evaluation acc. to the EU type approval certificate BVS 05 ATEX E 023.

In the following, all above mentioned versions are called VEGADIS 81. If parts of these safety instructions refer only to certain versions, then these will be mentioned explicitly with their type code.

# 2 Different ignition protection types

The VEGADIS 81 can be either used in explosive dust atmospheres or in explosive gas atmospheres.

The operator must specify the selected ignition protection type before installation. The selected ignition protection must be determined by marking it firmly on the identification label of the type plate.

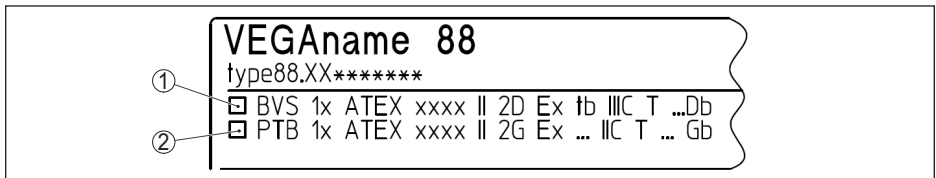

- 1 Identification label: Ignition protection type "Protection by enclosure Ex t"
- 2 Identification label: Ignition protection type "Flameproof enclosure Ex db"

<sup>1)</sup> Approval area "Combination": Combination of approval Ex ia acc. to ATEX, IECEX, FM and CSA.

### 3 Important specification in the type code

#### VEGADIS 81 model DIS81(\*).abcdefghi

Position		Feature	Description
a	Scope	A	ATEX / Europa
b	Approval	R	II 2D Ex tb IIIC T... Db
		H	II 1G, 2G Ex ia IIC T6...T1 Ga, Gb or II 2D Ex tb IIIC T... Db
		J	II 2G Ex db IIC T6...T1 Gb or II 2D Ex tb IIIC T... Db
c	Electronics	I	Digital (I <sup>2</sup> C communication)
d	Housing	A	Aluminium
		H	Special colour, Aluminium
		V	Stainless steel (precision casting)
e	Protection rating	N	IP66/IP68 NEMA 6P (0.2 bar)
f	Cable entry / Connection	1	M20 x 1.5 / without
		D	M20 x 1.5 / Blind plug
		O	M20 x 1.5 / Cable gland brass nickel-plated (ø 6 ... 12 mm), Ex db + Ex ta
		6	M20 x 1.5 / Cable gland brass nickel-plated (ø 9 ... 13 mm), for shielded cable, Ex db + Ex ta
		Q	½ NPT / without
		N	½ NPT / Blind plug
		P	½ NPT / Cable gland brass nickel-plated (ø 6 ... 12 mm), Ex db + Ex ta
		8	½ NPT / Cable gland brass nickel-plated (ø 9 ... 13 mm), for shielded cable, Ex db + Ex ta
g	Display and adjustment module PLICSCOM	X	without
		A	mounted
		K	mounted; with Bluetooth, magnetic pen operation
		U	mounted; with Bluetooth (US version), battery, magnetic pen operation
h	Mounting type	A	Wall mounting with Aluminium or stainless steel housing
		D	Carrier rail with Aluminium or stainless steel housing
		E	Tube mounting (26 ... 60 mm)
i	Certificates	X	without
		M	with

### 4 General information

The VEGADIS 81 with ignition protection type "Dust ignition protection by enclosure Ex t" is used for



spatially separated scaling, parameter adjustment and visualization of measured values

The VEGADIS 81 are suitable for use in hazardous atmospheres of all combustible substances of explosion group IIIA, IIIB and IIIC. The VEGADIS 81 are suitable for applications requiring category 2D (EPL Db) instruments.

## 5 Application area

### Category 2D (EPL Db instruments)

The VEGADIS 81 with the mechanical fixing element are installed in hazardous areas of zone 21 requiring category 2D (EPL Db) instruments.

VEGA Instrument	2D (EPL Db)
Ex Zone 21 	

## 6 Special operating conditions

The following overview lists all special features of VEGADIS 81.

### Ambient temperature

You can find the details in chapter " *Thermal data*" of these safety instructions.

### Impact and friction sparks

The VEGADIS 81 in light metal versions (e.g. aluminium, titanium, zircon) must be mounted in such a way that sparks from impact and friction between light metals and steel (except stainless steel, if the presence of rust particles can be excluded) cannot occur.

### Non-grounded, metallic parts

The resistance between aluminium housing to metal measuring point identification plate is  $> 10^9$  Ohm.

The capacitance of the metal measuring point identification plate was measured as follows:

Measurement loop identification label	Capacitance
45 x 23 mm (standard)	21 pF
100 x 30 mm	52 pF
73 x 47 mm	61 pF

## 7 Important information for mounting and maintenance

### General instructions

The following requirements must be fulfilled for mounting, electrical installation, setup and maintenance of the instrument:

- The staff must be qualified according the respective tasks
- The staff must be trained in explosion protection
- The staff must be familiar with the respectively valid regulations, e.g. planning and installation acc. to IEC/EN 60079-14
- Make sure when working on the instrument (mounting, installation, maintenance) that there is no explosive atmosphere present, the supply circuits should be voltage-free, if possible.

- The instrument has to be mounted according to the manufacturer specifications, the EU type approval certificate and the valid regulations and standards
- Modifications on the instrument can influence the explosion protection and hence the safety, therefore repairs are not permitted to be conducted by the end user
- Modifications must only be carried out by employees authorized by VEGA company
- Use only approved spare parts
- Components for installation and connection not included in the approval documents are only permitted if these correspond technically to the latest standard mentioned on the cover sheet. They must be suitable for the application conditions and have a separate certificate. The special conditions of the components must be noted and if necessary, the components must be integrated in the type test. This applies also to the components already mentioned in the technical description.
- Vessel installations and probable flow must be taken into account

### **Cable and wire entries**

- The VEGADIS 81 must be connected via suitable cable gland or conduit systems that are in conformity with the requirements of the flame proofing and the IP protection and provided with a separate type approval certificate. When connecting VEGADIS 81 to conduit systems, the corresponding sealing facility must be connected directly to the housing.
- The red thread or/dust covers screwed in when the instruments are shipped (depending on the version) must be removed before setup and replaced by cable entries or closing screws suitable for the respective ignition protection type and IP protection.
- Note type and size of the thread: A label with the respective thread name is in the area of the respective thread
- Threads must have no damages
- Cable entries and closing screws should be mounted correctly and according to the safety instructions of the manufacturer to ensure the specified ignition protection type and IP protection rating. When using certified or suitable cable glands, closing screws or plug connections, it is absolutely necessary to note the corresponding certificates/documents. Supplied cable entries or closing screws meet these requirements.
- Unused openings must be closed with plugs suitable for the ignition protection type and IP protection. Supplied plugs meet these requirements.
- Cable or wire entries resp. the closing screws must be tightly screwed into the housing
- The connection cables resp. pipeline sealing facilities must be suitable for the application conditions (e.g. temperature range) of the application
- With surface temperatures > 70 °C, the cables must be suitable for the higher application conditions
- The connection cable of VEGADIS 81 has to be wired fix and in such a way that damages can be excluded.

Aluminium/Stainless steel "Ex t" housing

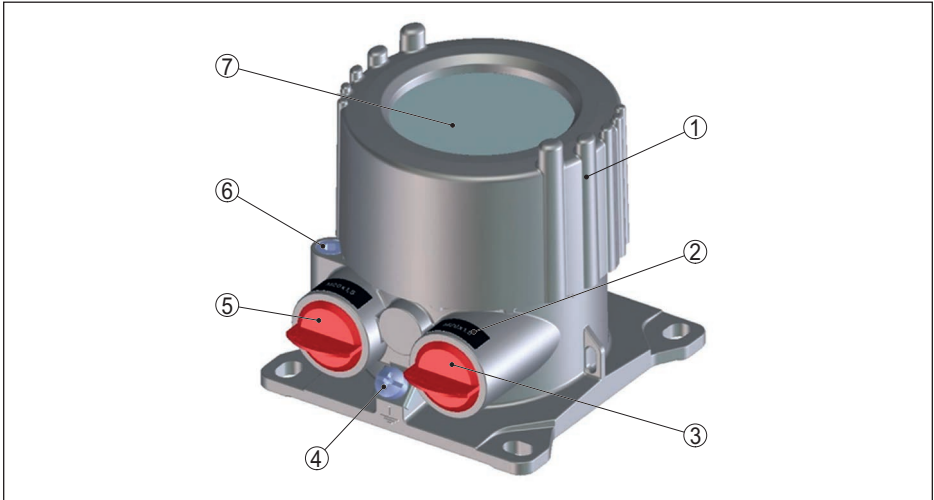

- 1 "Ex t" connection compartment with electronics module
- 2 Type of thread
- 3 Red threaded or dust protection cap
- 4 External ground terminal
- 5 Red threaded or dust protection cap
- 6 Locking screw of the lid
- 7 Inspection window of glass

**Mounting**

Keep in mind for instrument mounting

- Mechanical damage on the instrument must be avoided
- Mechanical friction must be avoided
- Vessel installations and probable flow must be taken into account
- Process connections separating two areas of different Ex-zones must comply to valid regulations and standards and the protection rating must be in conformity to IEC/EN 60529
- Close the housing lid (s) up to the stop before starting operating, to ensure the IP protection rating specified on the type label
- Protect the lid against unauthorized opening by unscrewing the locking screw up to the stop. With double chamber housing, you have to protect both lids.

**Maintenance**

To ensure the functionality of the device, periodic visual inspection is recommended for:

- Secure mounting
- No mechanical damages or corrosion
- Worn or otherwise damaged cables
- No loose connections of the line connections, equipotential bonding connections
- Correct and clearly marked cable connections

The parts of the VEGADIS 81 being in contact with flammable media during operation must be included in the periodic overpressure test of the plant.



## Dust ignition protection by enclosure "t"

- The terminals for connecting the operating voltage or signal circuits are integrated in the connection compartment with type of protection dust explosion protection by housing "t"
- Cable, wire entries and the closing screws must be certified acc. to ignition protection type dust ignition protection by enclosure "t"
- Cable, wire entries resp. the closing screws in simple construction must not be used
- Separately certified cable and wire entries can determine the permissible ambient temperature range or the temperature classes

## 8 Safe operating mode

### General operating conditions

- Do not operate the instrument outside the electrical, thermal and mechanical specifications of the manufacturer
- Use the instrument only in media against which the wetted parts are sufficiently resistant
- Note the relation between process temperature on the sensor/antenna and the permissible ambient temperature on the electronics housing. For permissible temperatures, see the respective temperature tables. See chapter " *Thermal data*".
- If necessary, a suitable overvoltage arrester can be connected in front of the VEGADIS 81
- For assessment and reduction of the explosion risk, valid standards such as for example ISO/EN 1127-1 must be taken into account
- Lids must not be opened if there is a hazardous atmosphere. The housing lids are marked with the warning label:

WARNING - DO NOT OPEN WHEN AN  
EXPLOSIVE ATMOSPHERE IS PRESENT

## 9 Potential equalization/Grounding

- Integrate the instruments into the local potential equalisation, e.g. via the internal or external earth terminal
- If grounding of the cable screening is necessary, this must be carried out acc. to the valid standards and regulations, e.g. acc. to IEC/EN 60079-14
- The potential equalization terminal must be secured against loosening and twisting.
- Make sure that you connect a ground cable. For external grounding, use M5 Crimp connections ( $\geq 4 \text{ mm}^2$ ) with spring, lock washer and clamp bracket to avoid loosening and twisting. The ground cable ( $\geq 1.5 \text{ mm}^2$ ,  $\leq \text{AWG } 16$ ) should be dismantled at the end over a length of 10 mm and fastened to the M5 Crimp connection (with a suitable Crimp tool).

## 10 Electrostatic charging (ESD)

In case of instrument versions with electrostatically chargeable plastic parts, the danger of electrostatic charging and discharging must be taken into account!

The following parts can charge and discharge:

- Lacquered housing version or alternative special lacquering
- Plastic housing, plastic housing parts
- Metal housing with inspection window
- Plastic process fittings
- Plastic-coated process fittings and/or plastic-coated sensors
- Connection cable for separate versions
- Type label

- Isolated metallic labels (measuring point identification plate)

Take note in case of danger of electrostatic charges:

- Avoid friction on the surfaces
- Do not dry clean the surfaces

The instruments must be mounted/installed in such a way that the following can be ruled out:

- in the case of extremely flammable dusts with a minimum ignition energy of less than 3 mJ, the device must not be used in areas where intensive electrostatic charging processes can be expected
- electrostatic charges during operation, maintenance and cleaning.
- process-related electrostatic charges, e.g. by measuring media flowing past

The warning label indicates danger:

**WARNING - POTENTIAL ELECTROSTATIC CHARGING HAZARD - SEE INSTRUCTIONS**

## 11 Electrical data

<p><b>Supply and signal circuit:</b> Terminals 5, 6, 7, 8</p>	<p><math>U \leq 6,4 \text{ V DC}</math> <math>P \leq 332 \text{ mW}</math> For connection to the indicating and adjustment circuit, terminal 5, 6, 7, 8 of the certified VEGAPULS, VEGAFLEX, VEGASON, VEGACAL, VEGABAR, VEGADIF and PROTRAC instruments in the ignition protection type "Dust ignition protection by enclosure Ex t".</p>
<p><b>Display and adjustment circuit:</b> Spring contacts in the connection compartment</p>	<p>Only for connection to the display and adjustment module PLICSCOM or for service purposes the interface adapter VEGACONNECT (PTB 07 ATEX 2013 X), if it is ensured that no explosive atmosphere is present!</p>

The circuits of VEGADIS 81 are galvanically separated from ground.

## 12 Thermal data

### Category 2D (EPL Db instruments)

Permissible ambient temperature	-40 ... +60 °C (-40 ... +140 °F)
Max. surface temperature	Ambient temperature +12 K
Housing protection rating	IP66
Ground terminal (connection cross-section)	$\geq 4 \text{ mm}^2$

The application conditions during operation without explosion-endangered atmosphere are mentioned in the respective manufacturer instructions, e.g. operating instructions manuals.



Printing date:

# VEGA

All statements concerning scope of delivery, application, practical use and operating conditions of the sensors and processing systems correspond to the information available at the time of printing.

Subject to change without prior notice

© VEGA Grieshaber KG, Schiltach/Germany 2021



55131-EN-211124

VEGA Grieshaber KG  
Am Hohenstein 113  
77761 Schiltach  
Germany

Phone +49 7836 50-0  
E-mail: [info.de@vega.com](mailto:info.de@vega.com)  
[www.vega.com](http://www.vega.com)