

Supplementary instructions

Mounting adapter PTB 9

For mounting on the existing mounting bracket (GM-16™)

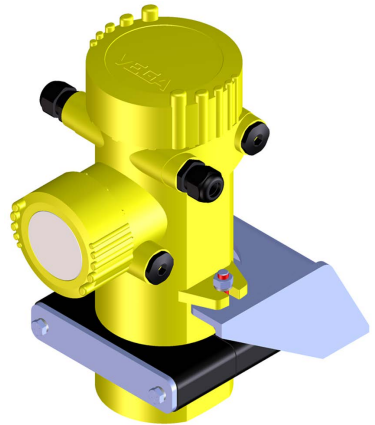

Document ID: 55642



VEGA

Contents

- 1 Product description**
- 2 Mounting**
 - 2.1 Mounting the mounting adapter..... 4
 - 2.2 Mounting of the anti-vibration clamp..... 5
- 3 Supplement**
 - 3.1 Technical data 8
 - 3.2 Dimensions 9
 - 3.3 Industrial property rights..... 11
 - 3.4 Trademark 11

1 Product description

The PTB 9 is a mounting adapter for the radiation-based measuring system MINITRAC 31 or POINTRAC 31 (short version with 46 mm/1.8 in). The PTB 9 can be mounted on an existing mounting bracket of GM-16.

Mounting adapter PTB 9, standard version

The standard version of PTB 9 for mounting on an existing mounting bracket GM-16.

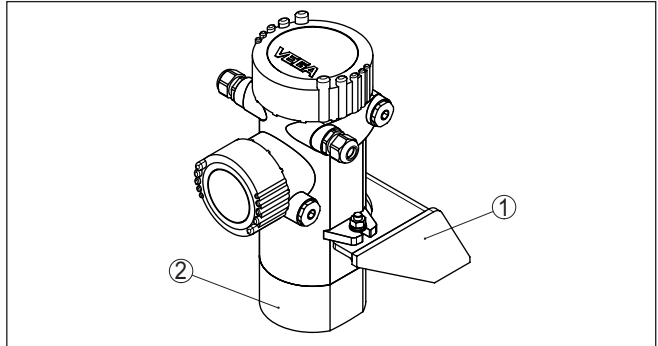

Fig. 1: Mounting adapter PTB 9 in mounted state

- 1 Mounting adapter PTB 9
- 2 Radiation-based sensor MINITRAC 31 or POINTRAC 31 (version with 46 mm/1.8 in)

Mounting adapter PTB 9, vibration resistant version

In applications where strong vibration can occur, you can equip the mounting adapter PTB 9 with an additional anti-vibration clamp.

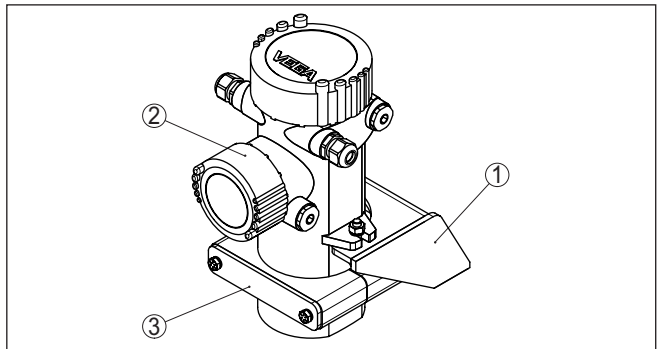

Fig. 2: Mounting adapter PTB 9 with anti-vibration clamp in mounted state

- 1 Mounting adapter PTB 9
- 2 Radiation-based sensor MINITRAC 31 or POINTRAC 31 (version with 46 mm/1.8 in)
- 3 Anti-vibration clamp

2 Mounting

2.1 Mounting the mounting adapter

Mounting adapter PTB 9, standard version

Mount the mounting adapter and the sensor according to the following assembly drawing:

As far as not otherwise stated, all parts are in the scope of delivery.

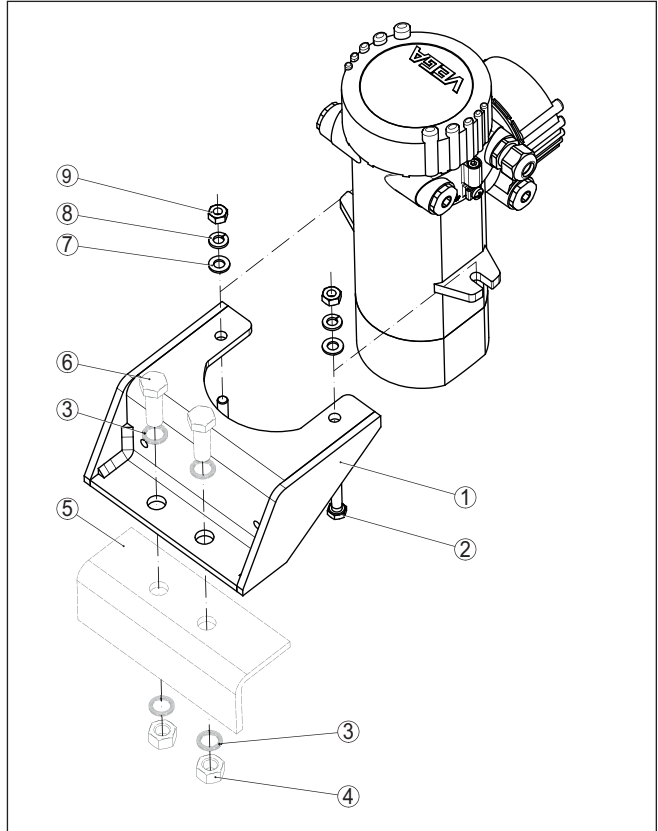

Fig. 3: Mounting of the mounting adapter (standard version)

- 1 Mounting adapter PTB 9
- 2 Screws M8 x 30 (2 pieces)
or screw 5/16" x 1 1/4" (2 pieces)
- 3 Washer - provided by customer
(recommendation: M12 or 1/2", 4 pieces)
- 4 Hexagon nut - provided by customer (recommendation: M12 or 1/2",
2 pieces)
- 5 Mounting bracket for GM-16 (provided by customer)
- 6 Screw - provided by customer (2 pieces)
Recommendation: M12 x 30 or 1/2" x 1 1/4"
- 7 Washer M8 or 5/16" (4 pieces)
- 8 Spring ring M8 or 5/16" (2 pieces)
- 9 Hexagon nut M8 or 5/16" (2 pieces)

**Danger:**

Before mounting, make sure that the corresponding radiation source is securely closed. Use a padlock to secure the source holder in the closed condition and prevent it from being inadvertently opened. Also take note of the instructions in the operating instructions manual of the source holder.

1. Place the mounting adapter (1) according to the above illustration onto the existing mounting bracket (5).
2. The fixing material for the mounting adapter is not part of the scope of delivery.

We recommend screws of size M12 or ½".

Insert the fixing screws (6) with the washers (3) from above through the holes of the mounting adapter (1) and the mounting bracket (5).

3. Place two washers (3) over the screws from below and screw the hexagon nuts (4) onto the screws (6).

Tighten the screws (6) with a torque of 60 Nm (44 lbf ft).

4. Place the sensor according to above illustration onto the mounting adapter (1).
5. Insert the two screws (2) from below through the holes of the mounting adapter (1).
6. Place one regular washer (7) and one lock washer (8) over each screw from above and screw the hexagon nuts (9) onto the screws (2).

Tighten the screws (2) with a torque of 15 Nm (11 lbf ft).

The radiation-based sensors MINITRAC 31 or POINTRAC 31 in the short version (46 mm/1.8 in) can be used instead of the sensor GM-16.

The mounting adapter is constructed in such a way that the sensors are already in the correct position after mounting.

2.2 Mounting of the anti-vibration clamp

Mounting adapter PTB 9, vibration resistant version

In applications where strong vibration is expected, you can equip the mounting adapter with an additional anti-vibration clamp.

As far as not otherwise stated, all parts are in the scope of delivery.

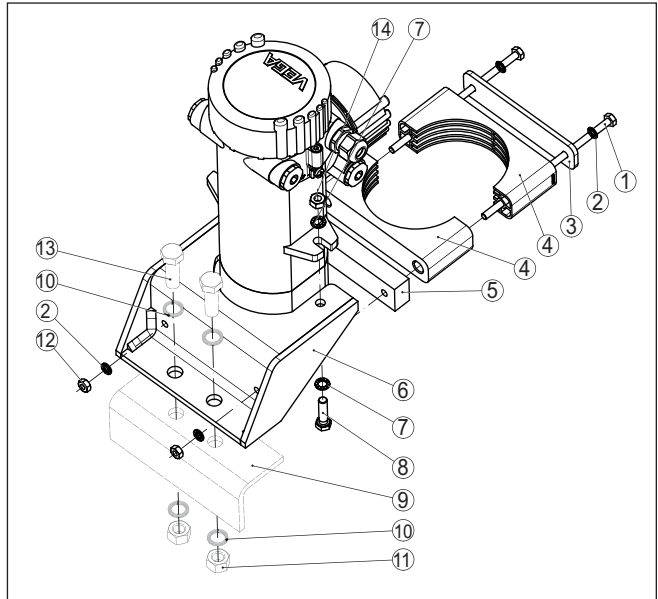

Fig. 4: Mounting of the mounting adapter with anti-vibration clamp

- 1 Screw M6 x 160 (2 pieces)
or screw 1/4" x 6 1/2" (2 pieces)
- 2 Lock washer - Nordlock for M6 or 1/4" (4 pieces)
- 3 Cover plate (1 piece)
- 4 Clamp collars (2 pieces)
- 5 Base (1 piece)
- 6 Mounting adapter PTB 9
- 7 Lock washer - Nordlock for M8 or 5/16" (4 pieces)
- 8 Screws M8 x 30 (2 pieces)
or screw 5/16" x 1 1/4" (2 pieces)
- 9 Mounting bracket for GM-16 (provided by customer)
- 10 Washer - provided by customer (recommendation: Nordlock M12 or 1/2",
4 pieces)
- 11 Hexagon nut - provided by customer (recommendation: M12 or 1/2",
2 pieces)
- 12 Hexagon nut M6 or 5/16" (2 pieces)
- 13 Screw - provided by customer (2 pieces)
Recommendation: M12 x 30 or 1/2" x 1 1/4"
- 14 Hexagon nut M8 or 5/16" (2 pieces)



Danger:

Before mounting, make sure that the corresponding radiation source is securely closed. Use a padlock to secure the source holder in the closed condition and prevent it from being inadvertently opened. Also take note of the instructions in the operating instructions manual of the source holder.

1. Place the mounting adapter (6) according to the above illustration onto the existing mounting bracket (9).

2. The fixing material for the mounting adapter is not part of the scope of delivery.
We recommend screws of size M12 or ½" and Nordlock washers. Insert the fixing screws (13) with the Nordlock lock washers (10) from above through the holes of the mounting adapter (6) and the mounting bracket (9).
3. Place two Nordlock lock washers (10) over the screws from below and screw the hexagon nuts (11) onto the screws (13).
Tighten the screws (13) with a torque of 60 Nm (44 lbf ft).
4. Insert the screws (1), each with one Nordlock lock washer (2) according to the above illustration, through the cover plate (3), the two clamp collars (4) and the base plate (5).
5. Place the premounted anti-vibration clamp onto the mounting adapter (6) and screw the two screws (1) from the front through the holes of the mounting adapter (6).
Place one Nordlock lock washer (2) over each of the screws (1) and screw the hexagon nuts (12) onto the screws (1). Do not tighten the hexagon nuts, the connection should be still loose.
6. Place the sensor onto the mounting adapter (6) according to the above illustration.
Insert the lower part of the sensor into the loosely premounted anti-vibration clamp.
7. Place one Nordlock lock washer (7) over each of the two screws (8) and insert the screws from below through the holes of the mounting adapter (6).
8. Place one Nordlock lock washer (7) over each screw (8) and screw the hexagon nuts (14) onto the screws (8).
Tighten the screws (8) with a torque of 15 Nm (11 lbf ft) to fix the sensor.
9. Finally, tighten the screw connections (1) of the anti-vibration clamp with a torque of 10 Nm (7.5 lbf ft).

The radiation-based sensors MINITRAC 31 or POINTRAC 31 in the short version (46 mm/1.8 in) can be used instead of the sensor GM-16.

The mounting adapter is constructed in such a way that the sensors are already in the correct position after mounting.

3 Supplement

3.1 Technical data

General data

Take note of the information in the operating instructions manual of the installed MINITRAC 31, POINTRAC 31 series level sensor and the source holder

Material 316L corresponds to 1.4404 or 1.4435

Materials

- Mounting adapter 316L
- Anti-vibration clamp - cover plate and base plate 316L
- Anti-vibration clamp - clamp collars Plastic PA

Weight

- Standard version 2.2 kg (4.9 lbs)
- Version with anti-vibration clamp 3.2 kg (7.1 lbs)

Torques

- Screws - Fastening, mounting adapter (M12 or ½") 60 Nm (44 lbf ft)
- Screws - Fastening, sensor (M8 or 5/16") 15 Nm (11 lbf ft)
- Screws - anti-vibration clamp (M6 or ¼") 10 Nm (7.5 lbf ft)

3.2 Dimensions

Mounting adapter, standard version

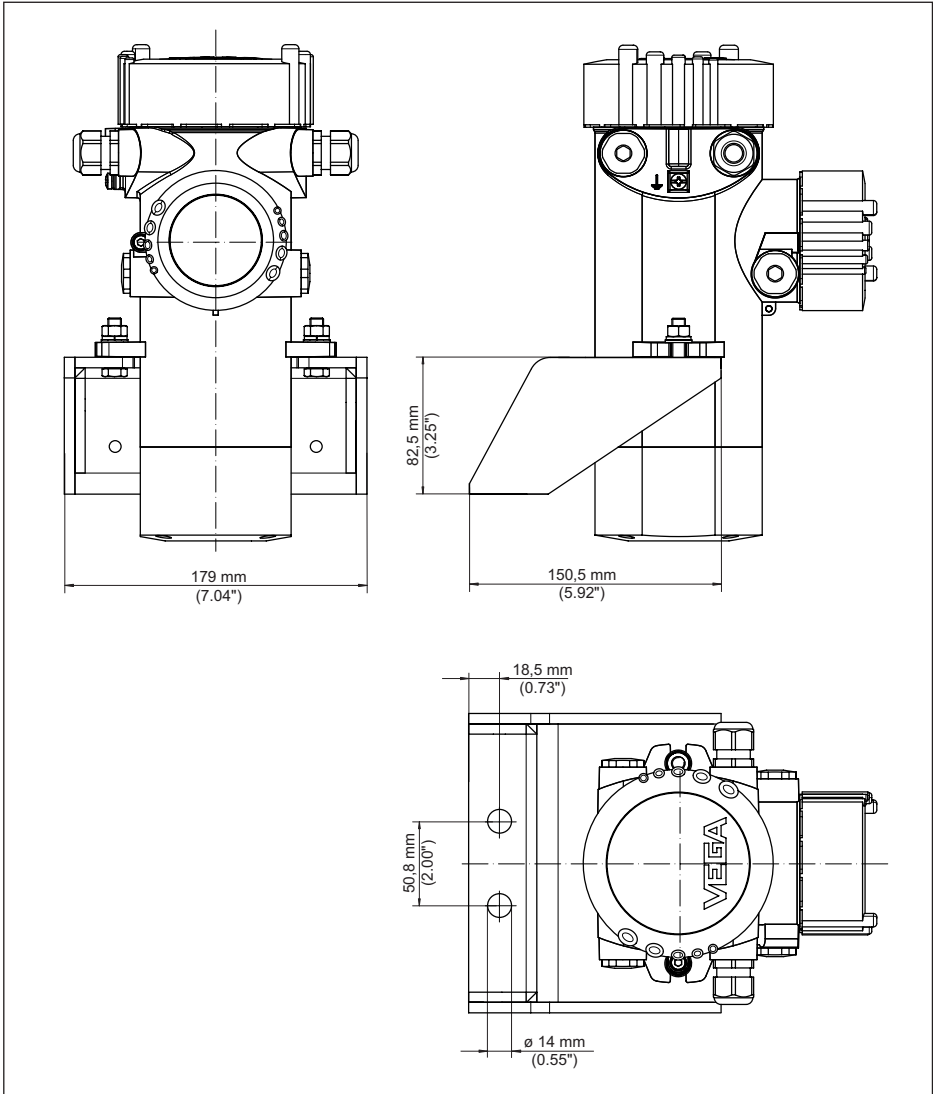

Fig. 5: Mounting adapter PTB 9, standard version

Mounting adapter, vibration resistant version

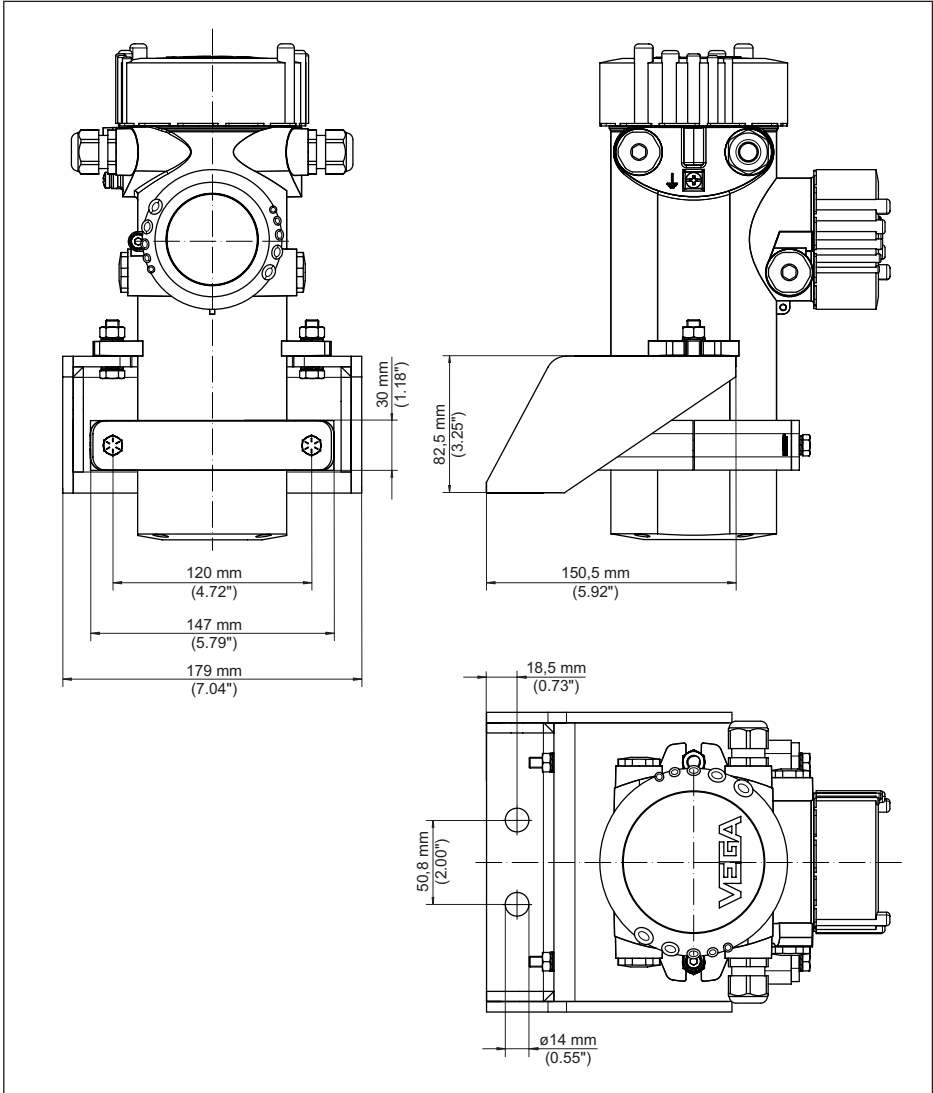

Fig. 6: Mounting adapter PTB 9, vibration resistant version

3.3 Industrial property rights

VEGA product lines are global protected by industrial property rights. Further information see www.vega.com.

VEGA Produktfamilien sind weltweit geschützt durch gewerbliche Schutzrechte.

Nähere Informationen unter www.vega.com.

Les lignes de produits VEGA sont globalement protégées par des droits de propriété intellectuelle. Pour plus d'informations, on pourra se référer au site www.vega.com.

VEGA líneas de productos están protegidas por los derechos en el campo de la propiedad industrial. Para mayor información revise la pagina web www.vega.com.

Линии продукции фирмы ВЕГА защищаются по всему миру правами на интеллектуальную собственность. Дальнейшую информацию смотрите на сайте www.vega.com.

VEGA系列产品在全球享有知识产权保护。

进一步信息请参见网站www.vega.com。

3.4 Trademark

All the brands as well as trade and company names used are property of their lawful proprietor/originator.

Printing date:

VEGA

All statements concerning scope of delivery, application, practical use and operating conditions of the sensors and processing systems correspond to the information available at the time of printing.

Subject to change without prior notice

© VEGA Grieshaber KG, Schiltach/Germany 2017



55642-EN-170815

VEGA Grieshaber KG
Am Hohenstein 113
77761 Schiltach
Germany

Phone +49 7836 50-0
Fax +49 7836 50-201
E-mail: info.de@vega.com
www.vega.com