

Supplementary instructions

Air cooling - FIBERTRAC 32 with Conduit tube connection

Active air cooling system for radiometric sensors



Document ID: 55511



VEGA

Contents

1	Product description	3
1.1	Configuration	3
2	Mounting	5
3	Replacement parts	17
3.1	Available spare parts - air cooling	17
4	Supplement	19
4.1	Technical data	19
4.2	Dimensions	20

1 Product description

1.1 Configuration

The active air cooling system is suitable for radiometric sensors of series FIBERTRAC 32.

The air cooling system consists of several modules.

Housing cooling box (A) The housing cooling box is placed above the instrument housing and enables cooling of the instrument housing.

Housing cooling (B) The cooling module for the housing is also cooled by the housing cooling box (A).

Scintillator cooling (C) The cooling tube (provided by customer) for the sensor cools the active measuring part of the sensor.

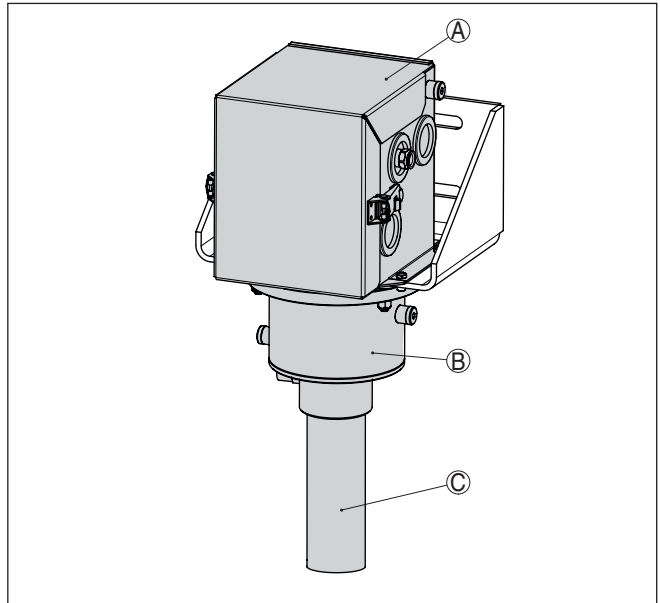

Fig. 1: Active air cooling system with fastening bracket

- A Housing cooling box
- B Housing cooling
- C Scintillator cooling tube (provided by customer)

Scope of delivery

The following parts belong to the scope of delivery of the air cooling system:

- Hexagon socket screw M5 x 14 (6 pieces)
- Spring ring for M5 (6 pieces)
- Fastening bracket
- Housing cooling box with detachable lid
- Isolating sleeve (6 pieces)

- Fixing screw M8 x 35 (2 pieces)
- Fixing screw M8 x 40 (4 pieces)
- Washer for M8 (10 pieces)
- Spring ring for M8 (2 pieces)
- Hexagon nut M8 (4 pieces)
- Vortex cooler (type FOS 208SS 25 HVE BSP) for housing cooling box - optional
- Vortex cooler (type FOS 208SS 35 HVE BSP) for scintillator cooling - optional
- Blind plug 1/4" (3 pcs.)
- NPT threaded adapter for vortex cooler (optional)



Information:

When the sensor is ordered with cooling, the sensor and the air cooling system are shipped pre-assembled.

If the air cooling system is ordered later, you have to mount it on the sensor yourself.

You can find further information in chapter " *Mounting*".

2 Mounting

Operating instructions

Mounting preparations

Take note of the operating instructions manuals of the corresponding radiometric sensors and the source holder.



Warning:

During all mounting and dismounting work, the source container must be in switch position "OFF" and secured by a lock.

Carry out all work within the shortest possible time and at the largest possible distance. Provide suitable shielding.

Avoid risk to other persons by taking suitable measures (e.g. safety fence, etc.).

Mounting may only be carried out by authorized, qualified personnel who are monitored for radiation exposure according to local laws or the handling permit. Take note of the specifications in the handling permit. Also take the local conditions into account.



Caution:

The cooling system is used in areas with high temperatures. Therefore, use temperature-resistant cable and install it in such a way that contact with hot components is avoided.

General mounting instructions



Information:

When the sensor is ordered with cooling, the sensor and the air cooling system are shipped pre-assembled.

If the air cooling system is ordered later, you have to mount it on the sensor yourself.

Required tools:

- Fork wrench SW13 mm (2 pieces) - for the housing cooling
- Fork wrench SW19 mm (2 pcs.) - for vortex coolers
- Acid-free grease - to screw in the compression nuts more easily

Take note of the following general mounting instructions:

- First of all, mount the fastening bracket and the housing cooling, and then the sensor.
- The small lid of the instrument housing must point to the front after mounting the fastening bracket (x)
- The sensor together with the air cooling system is very heavy. Use a suitable lifting device for mounting, e.g. a hoisting sling

Mounting

Mount the fastening bracket

1. Place the isolating sleeves (4) between the housing cooling (5) and the fastening bracket (1).

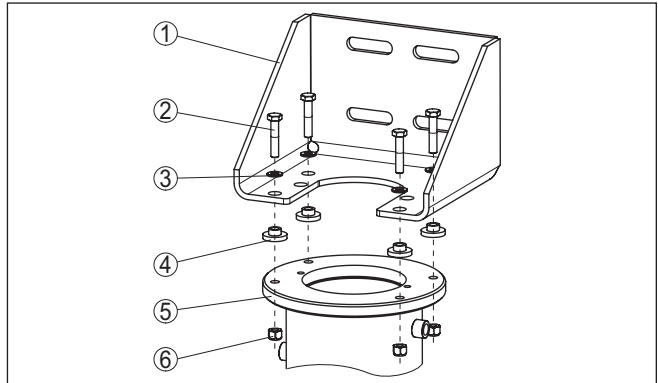

Fig. 2: Housing cooling with mounted sensor

- 1 Fastening bracket
- 2 Hexagon screw M8 (4 pieces)
- 3 Washer for M8 (4 pieces)
- 4 Isolating sleeve (4 pieces)
- 5 Housing cooling
- 6 Hexagon nut M8 (2 pieces)

2. Place the fastening bracket (1) onto the housing cooling (5). Make sure that the cooling air connections point in a suitable direction. Rotating the fastening bracket later (1) is very difficult.
3. Connect the fastening bracket (1) with the housing cooling (5) according to the illustration and tighten the screws (2, 6) with a torque of 15 Nm (11.06 lbf ft).

Inserting the sensor

1. Insert the sensor into the housing cooling.

The small lid of the instrument housing must point to the front after mounting on the fastening bracket (x).

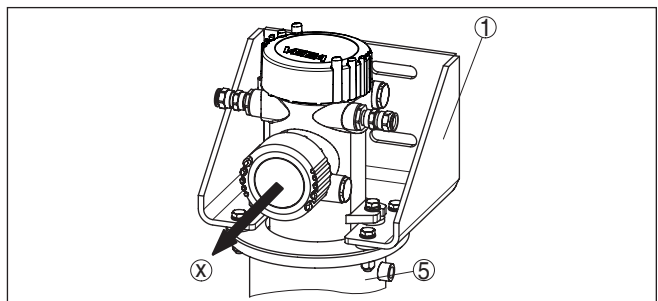

Fig. 3: Mounting direction of the sensor towards the fastening bracket

- 1 Fastening bracket
- 5 Housing cooling
- x Mounting direction of the housing

2. It is advisable to place the sensor and the housing cooling on the floor while inserting. Protect the sensor by covering the sensor housing during mounting.

Mount the sensor with the two screws (7) in the appropriate position.

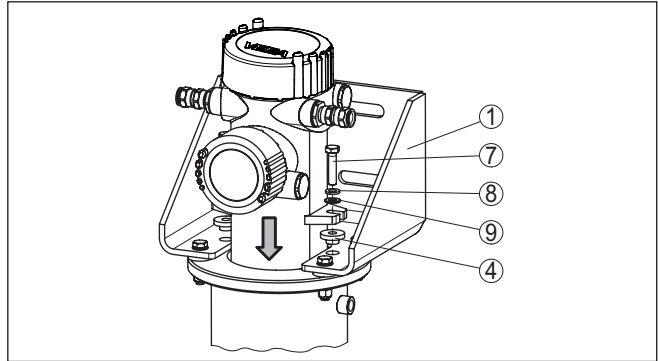

Fig. 4: Mounting the sensor

- 1 Fastening bracket
- 4 Isolating sleeve (2 pieces)
- 7 Hexagon screw M8 (2 pieces)
- 8 Retaining washer for M8 (2 pieces)
- 9 Washer for M8 (4 pieces)

Housing cooling

Take note of the following general mounting instructions:

- First of all, mount the fastening bracket and the housing cooling, and then the sensor
- The small lid of the instrument housing must point to the front after mounting the fastening bracket (x)
- The sensor together with the air cooling system is very heavy. Use a suitable lifting device for mounting

Mounting the scintillator cooling

Mount the scintillator cooling (customer-side) according to the following assembly drawing:

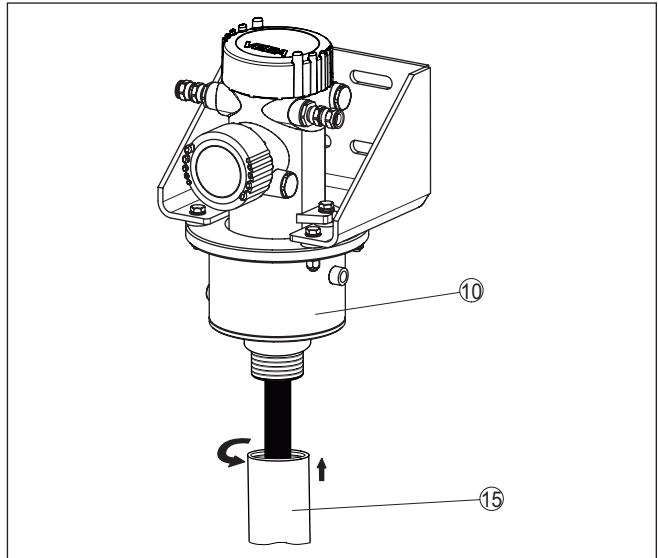

Fig. 5: Mounting the scintillator cooling

10 Housing cooling

15 Scintillator cooling tube with NPT connection thread 2½" (provided by customer)

1. Prepare a cooling tube (15), matching the length of the sensor. The cooling tube (15) must have an NPT inner thread size of 2½" on the upper side.
2. Push the cooling tube (15) provided by the customer from below onto the black scintillator of the sensor.
3. Grease the upper thread of the scintillator cooling tube (15) with acid-free grease. This makes screwing the parts together easier.
4. Push the cooling tube (15) provided by the customer from below into the thread of the sensor and screw the thread into the sensor.
5. The scintillator cooling tube (15) must remain open to the bottom. Make sure that the cooling air can escape freely.

The scintillator cooling is now completely mounted.

Lifting the air cooling system



Information:

The sensor together with the air cooling system is very heavy. Use a suitable lifting device for mounting.

Use a hoisting sling with sufficient loading capacity. Take note of the sling marking. You can find the respective weight of the air cooling system in chapter " *Technical data*".

Place the lifting sling around the cooling tube directly below the flange. The loop is a so-called lark's foot.

Fasten the hoisting sling according to the following illustration.

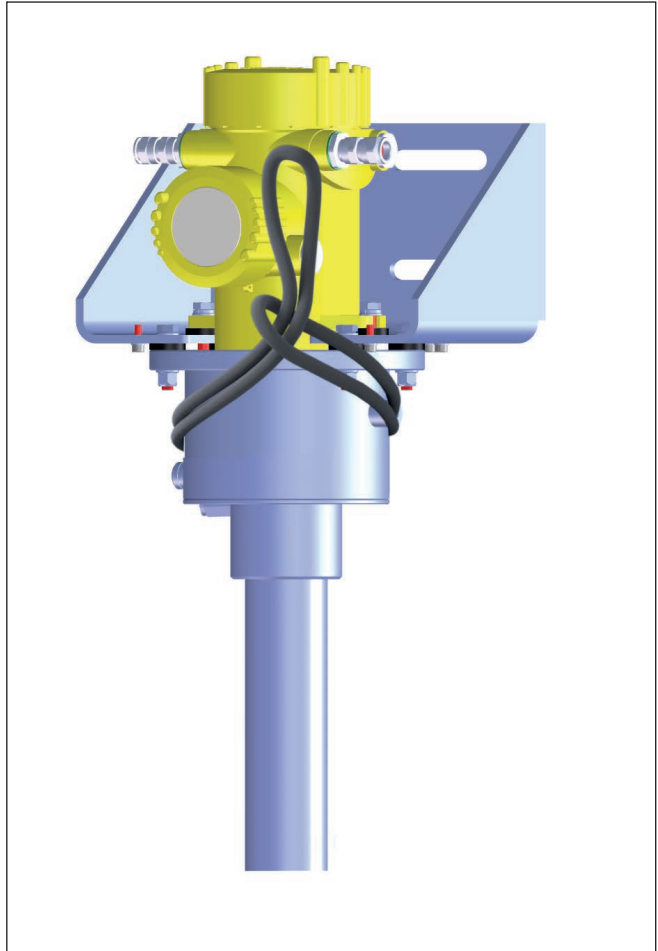

Fig. 6: Attaching the sling

Mounting the sensor

As soon as the air cooling system is mounted, you can install the sensor with the air cooling system in your facility.



Note:

The air cooling system does not come with components for fastening to the vessel. Use fastening elements that are appropriate to the situation in your plant.

→ Fasten the cooling tube (provided by customer) with suitable mounting clamps, brackets, etc.

Make sure that the tube is well secured against slippage.

You can find further information on sensor mounting in the operating instructions manual of the sensor.

Mounting the housing cooling box

1. Open the fasteners (36) and remove the lid (37) from the lower part of the housing cooling box (38).
2. To make mounting easier, screw the cable glands of the sensor out of the instrument housing.
3. Place the lower part of the housing cooling box (38) on the fastening bracket (1).
4. Insert the 6 hexagon socket screws (39) from below through the mounting bracket (1) and tighten the screws with a torque of 4.5 Nm (3.3 lbf ft).

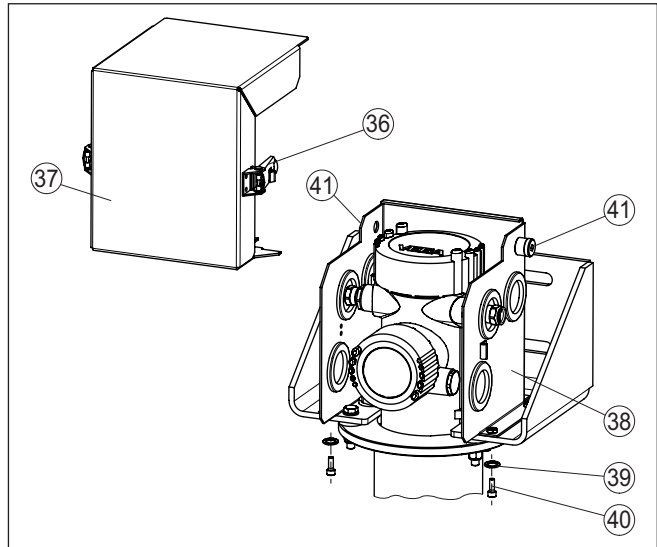

Fig. 7: Mounting the housing cooling box

36 Fasteners with safety latch

37 Lid of the housing cooling box

38 Lower part of the housing cooling box

39 Spring ring for M5 (6 pieces)

40 Hexagon socket screw M5 x 14 (6 pieces)

41 Connection opening for vortex cooler (type FOS 208SS 25 HVE BSP)

Electrical connection

1. Open the fasteners (36) and remove the lid from the housing cooling box (37).
2. Determine which cable gland you need for connection of the sensor.
3. Pierce a small hole with a sharp tool (e.g. pricking awl, scriber, etc.) in the center through the respective rubber diaphragms (42).
Do not use a knife or similar for puncturing

If you have accidentally pierced the wrong diaphragm, you can simply exchange the rubber diaphragms. If you have pierced a diaphragm too much, you can seal it with self-adhesive fabric tape.

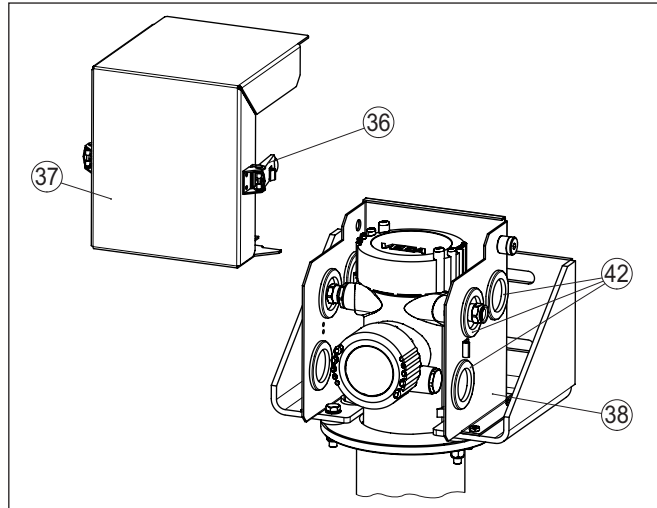

Fig. 8: Preparations for electrical connection

- 36 Fasteners with safety latch
- 37 Lid of the housing cooling box
- 38 Lower part of the housing cooling box
- 42 Rubber diaphragm

4. Insert the cable gland into the resulting opening and screw it tightly to the sensor housing.
Make sure that the rubber diaphragm encircles the cable gland completely so that not too much cooling air can escape.
5. Connect the sensor to voltage supply. Keep in mind the information in the operating instructions of the corresponding sensor or in the wiring diagram on the housing lid.



Note:

The cooling system is used in areas with high temperatures. Therefore, use temperature-resistant cable and install it in such a way that contact with hot components is avoided.

6. From the front side, place the lid of the housing cooling box (37) onto the lower part of the housing cooling box (38).
7. Close the two lateral fasteners (36).
Make sure that the fasteners (36) are provided with safety latches against unintentional opening. To open a fastener, you have to press the safety latch.

Connect cooling

The scintillator cooling and the housing cooling box must be connected to the cooling system.

All threads for the cooling connection on the sensor are inner threads.

Two cooling methods are possible:

- Eddy current cooler (Vortex cooler)
- Compressed air (from the workshop compressed air system)

Combinations of the two cooling methods are also possible.

In this case we recommend using vortex coolers. The direct connection to the sensor as well as the defined, plannable cooling effect of vortex coolers allow effective cooling of the measuring point.

If compressed air from the workshop compressed air system is used, the flow rate as well as the temperature of the compressed air are undefined. Effective cooling is not ensured.

Please contact VEGA service before planning your system.



Caution:

Make sure that a sufficient cooling effect is achieved before putting the measuring point into operation with workshop compressed air. The max. permissible temperature around the scintillator is +50 °C (+122 °F); this temperature must not be exceeded.

Cooling systems - vortex cooler

So-called Vortex coolers are proven possibilities for cooling the sensor.

You can connect the cooling air output of the vortex cooler directly to the housing cooling box or scintillator cooling.

Contact our sales staff to make sure the coolers fit perfectly to your air cooling system with respect to size, cooling capacity and throughput.

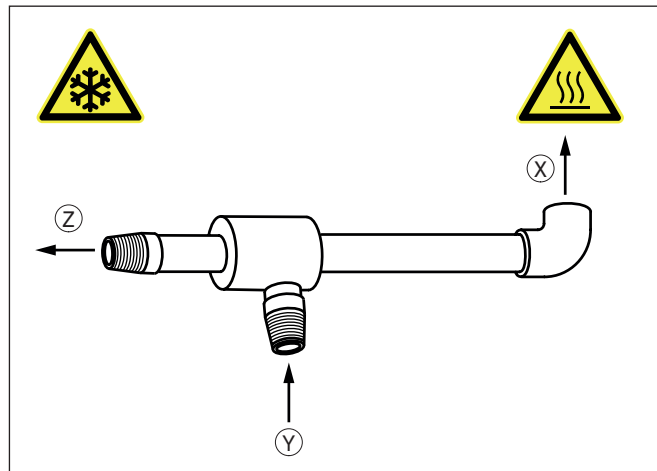

Fig. 9: Eddy current cooler (Vortex cooler)

- x Hot exhaust air
- y Supply air
- z Cooling air



Caution:

The vortex cooler gets very hot during operation. Hot air at approx. 100 °C (212 °F) escapes from the exhaust opening. Furthermore, the cooler or sensor can be very cold on the cold air side. Wear suitable protective clothing and prevent people from touching the cooling system by installing barriers, etc.

Make sure that the exhaust airstream can escape safely into the open. Make sure that no heat-sensitive components or cables are in the exhaust airstream.

If you want to direct the exhaust airstream in another direction, you have to use standard, angled metal fittings with ¼" screw connection.

1. The housing cooling box has two connection openings with ¼" connection.

Close the free openings with a respective bling plug.

2. The two lateral opening on the housing cooling have no function. Close the openings with the attached blind plugs to avoid penetration of dirt and moisture.

3. Connect the vortex coolers.

All threads for the cooling connection on the sensor are inner threads.

The vortex cooler type FOS 208SS 25 HVE BSP (optional) powers the housing cooling box.

The vortex cooler type FOS 208SS 35 HVE BSP (optional) is connected to the scintillator cooling

Screw in the short cooling air output of the vortex cooler and tighten it with a torque of 25 Nm (18.43 lbf ft).

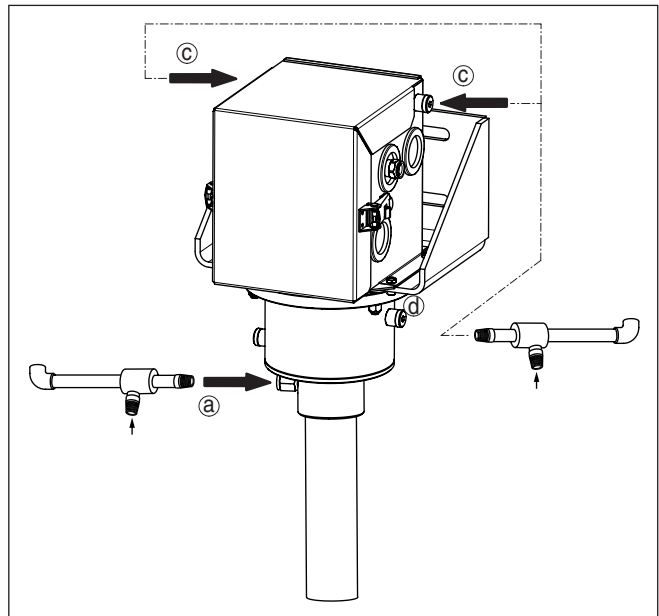

Fig. 10: Connection of the cooling air systems (vortex coolers)

- a Cooling air inlet - scintillator cooling
(vortex cooler type FOS 208SS 35 HVE BSP - optional)
- b Cooling air inlet - Housing cooling box
(vortex cooler type FOS 208SS 25 HVE BSP - optional)
Connection on the left or right possible

For cooling, use clean, water-free compressed air of class 3:3:2 acc. to ISO 8573-1:2010. Make sure that your compressor has enough supply capacity. You can find information on quality, pressure, throughput and temperature of the cooling air in chapter " *Technical data*".

Make sure that the cooling air inlets do not freeze, e.g. in case of a shutdown.



Caution:

Do not loosen any screws or connections during operation and make sure that the cooling air supply is reliable and interruption-free. Plan the necessary steps for a possible compressed air failure.

We recommend installing a temperature sensor (in the housing cooling box) that triggers an alarm when a critical temperature is reached.



If you want to use the air cooling in an SIL-qualified application, you have to assess the SIL failure rates of the complete air cooling system and the cooling air supply yourself.

Cooling systems - compressed air (provided by customer)

Compressed air from a workshop compressed air system is another possibility for cooling the sensor.

You can connect the air supply directly to the housing cooling box or to the scintillator cooling.

Adapt the cooling capacity and the flow rate to the requirements of your application.



Caution:

Make sure that the exhaust airstream can escape safely into the open.

The air can heat up extremely during cooling. Make sure that no heat-sensitive components or cables are in the exhaust airstream.

1. The housing cooling box has two connection openings with ¼" connection.

Close the free openings with a respective bling plug.

2. Connect the workshop compressed air line. For this, use a ¼" fitting or a respective adapter.

All threads for the cooling connection on the sensor are inner threads.

Screw in the cooling air line and tighten it with a torque of 25 Nm (18.43 lbf ft).

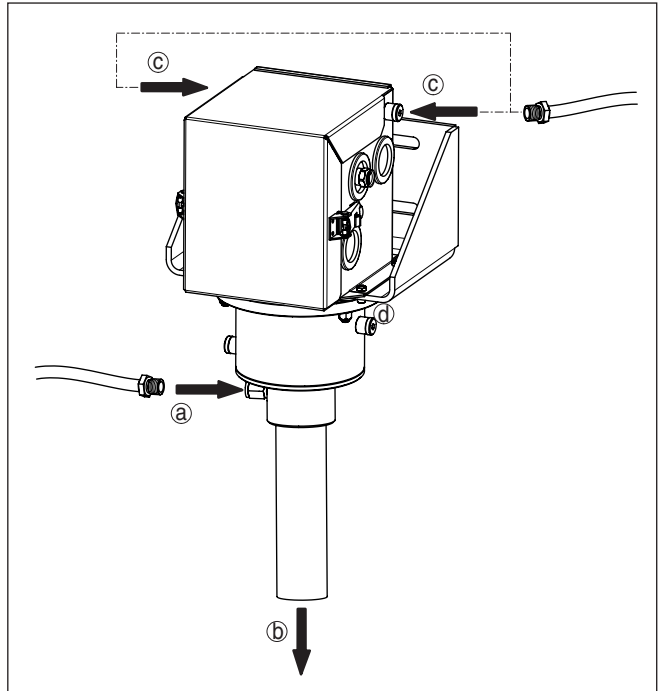

Fig. 11: Connection of the cooling lines

- a Cooling air inlet - scintillator cooling
 - b Cooling air outlet - scintillator cooling
 - c Cooling air inlet - Housing cooling box
- Connection on the left or right possible

For cooling, use clean, water-free compressed air of class 3:3:2 acc. to ISO 8573-1:2010. Make sure that your compressor has enough supply capacity. You can find information on quality, pressure, throughput and temperature of the cooling air in chapter " *Technical data*".



Caution:

Do not loosen any screws or connections during operation and make sure that the cooling air supply is reliable and interruption-free. Plan the necessary steps for a possible compressed air failure.

We recommend installing a temperature sensor (in the housing cooling box) that triggers an alarm when a critical temperature is reached.



If you want to use the air cooling in an SIL-qualified application, you have to assess the SIL failure rates of the complete air cooling system and the cooling air supply yourself.

Install a protective grid

Take note of the operating instructions manuals of the corresponding radiometric sensors and the source holder.

When handling radioactive substances, unnecessary radiation exposure must be avoided.

If there are gaps or intervening spaces after mounting, provide protective fences or grids to keep hands away from the dangerous area. Such areas must be marked accordingly.

Install a safety barrier on both sides of the cooling system. A sheet metal cover or an appropriately shaped plastic sheet can also be used.

3 Replacement parts

3.1 Available spare parts - air cooling

Selected components of the cooling are available as replacement parts. The following parts are available:

The stated quantity is the quantity delivered.

Air cooling with vortex cooler - Conduit connection

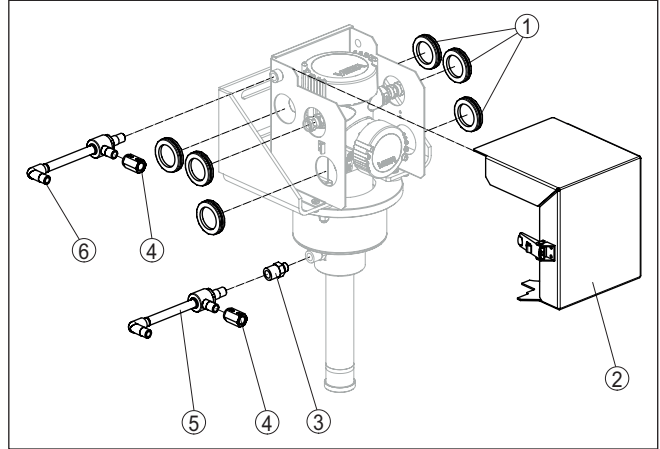

Fig. 12: Spare parts - air cooling with vortex cooler - scintillator cooling tube with Conduit connection

- 1 Rubber diaphragm (2 pcs.)
- 2 Lid of the housing cooling box
- 3 Distance threaded adapter for vortex cooler ¼ NPT (1 pce.)
- 4 Threaded adapter for vortex cooler ¼ NPT (1 pce.)
- 5 Vortex cooler type FOS 208SS 35 HVE BSP (input for cooling air - scintillator cooling)
- 6 Vortex cooler type FOS 208SS 25 HVE BSP (input for cooling air - housing cooling box)

Air cooling with compressed air connection (factory) - Conduit connection

Fig. 13: Spare parts - air cooling with compressed air connection (factory) - scintillator cooling tube with Conduit connection

- 1 Rubber diaphragm (2 pcs.)
- 2 Lid of the housing cooling box
- 3 Threaded adapter for compressed air connection $\frac{1}{4}$ NPT (1 pce.)

4 Supplement

4.1 Technical data

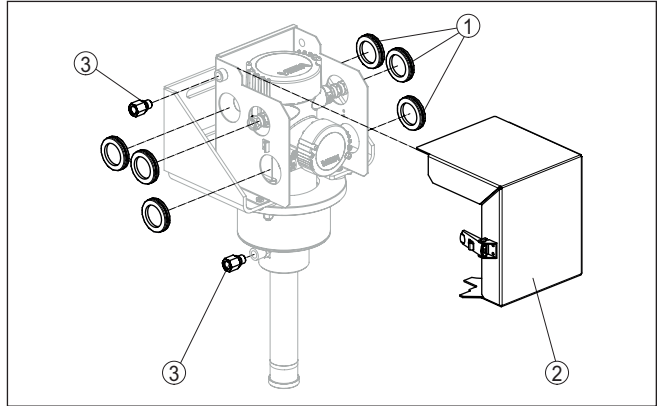
General data

Take note of the information in the operating instructions manual of the installed FIBERTRAC 31 level sensor and the source holder

Material 316L corresponds to 1.4404 or 1.4435

Materials

- Housing cooling 316L
- Housing cooling box 316L

Weight

- Housing cooling 2.3 kg (5.1 lbs)
- Housing cooling box 3.2 kg (7.1 lbs)
- Fastening bracket 4.8 kg (10.6 lbs)

Total length of the air cooling system max. 7 m (22.97 ft)

Cooling tube provided by customer

- Max. diameter - sensor hose 64 mm (2.52 in)
- Thread ¹⁾ 2½" NPSM - inner thread

Torques

- Screws, Sensor mounting (M8) 15 Nm (11.06 lbf ft)
- Nuts, housing cooling (M8) 15 Nm (11.06 lbf ft)
- Threaded fittings, vortex cooler i.e. compressed air 25 Nm (18.43 lbf ft)

Connection thread of the cooling air inputs ¼" DIN ISO 228 outer thread
(adapters for NPT fittings are enclosed with respective version)

Flow rate - vortex coolers

Quality of the compressed air ISO 8573-1:2010 [3:3:2]

Supply capacity - Compressor ²⁾

- Type FOS 208SS 25 HVE BSP ³⁾ 708 L/min (25 SCFM)
- Type FOS 208SS 35 HVE BSP ⁴⁾ 991 L/min (35 SCFM)

Air pressure of the supply air 5 ... 7.9 bar (72 ... 114 psig)

Temperature of the supply air +20 ... +25 °C (+68 ... +77 °F)

Ambient temperature

- Sensor length 0.3 ... 5 m (1 ... 16.4 ft) +80 °C (+176 °F)
- Sensor length 5 ... 7 m (16.4 ... 23 ft) +70 °C (+158 °F)

¹⁾ For connection to the sensor

²⁾ at 6.9 bar (100 psig)

³⁾ optional

⁴⁾ optional

Throughput - compressed air (provided by customer)

Quality of the compressed air	ISO 8573-1:2010 [3:3:2]
Air pressure of the supply air	Adapt the cooling capacity and the throughput to the requirements of your measuring point.
Temperature around the scintillator	max. +50 °C (+122 °F)

Approvals

If you use an air cooling system in hazardous areas, make sure that the max. permissible temperatures in the Ex safety instructions are maintained around the sensor. If this is ensured, the sensor can also be used with an air cooling system in hazardous areas.

4.2 Dimensions**Active air cooling system**

Fig. 14: Active air cooling system with scintillator cooling and housing cooling box

L Total length of the air cooling system





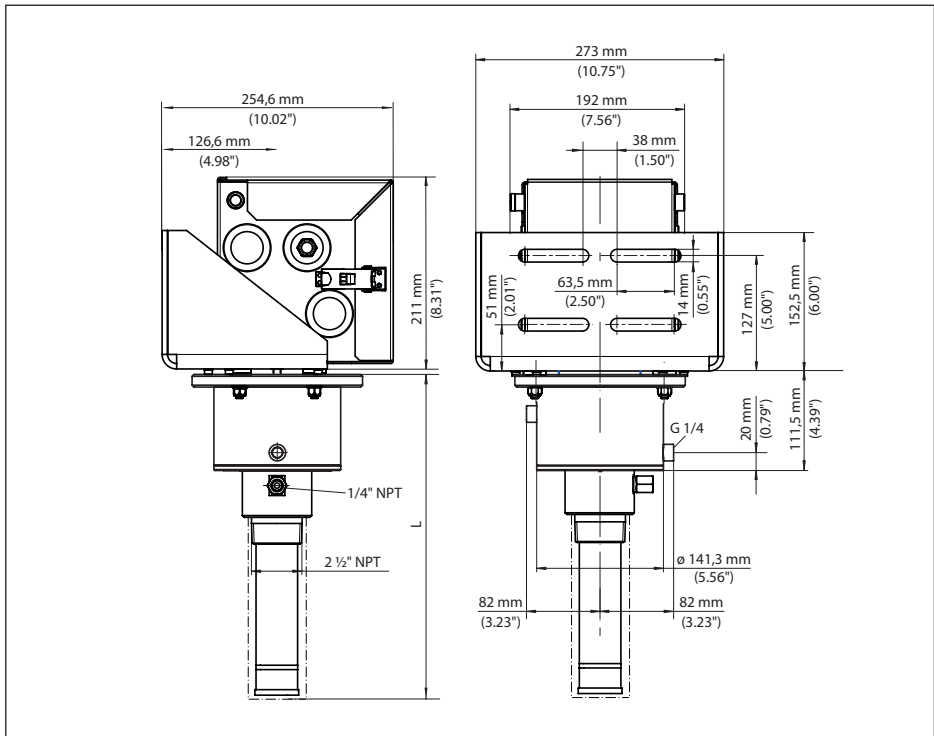
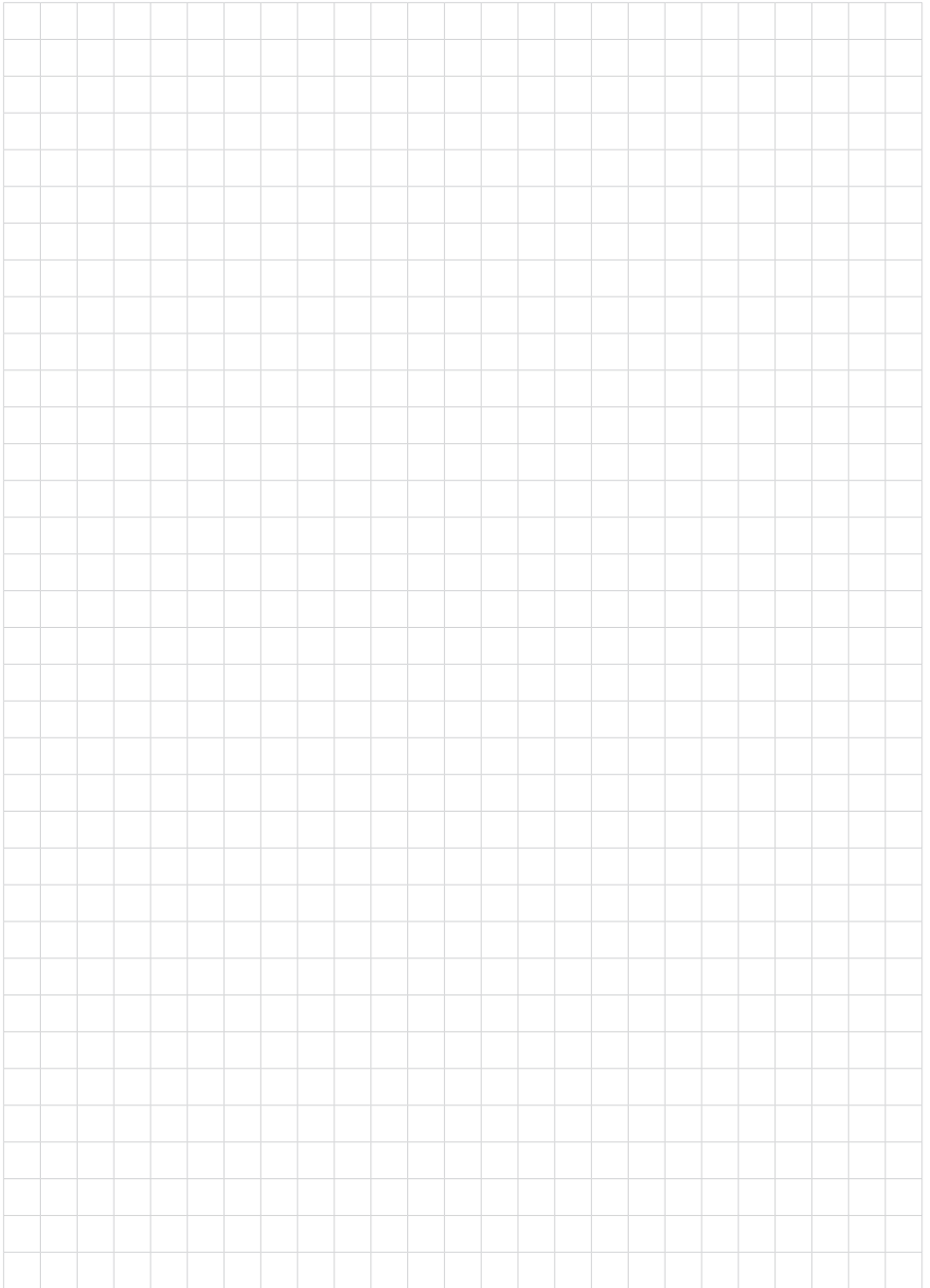
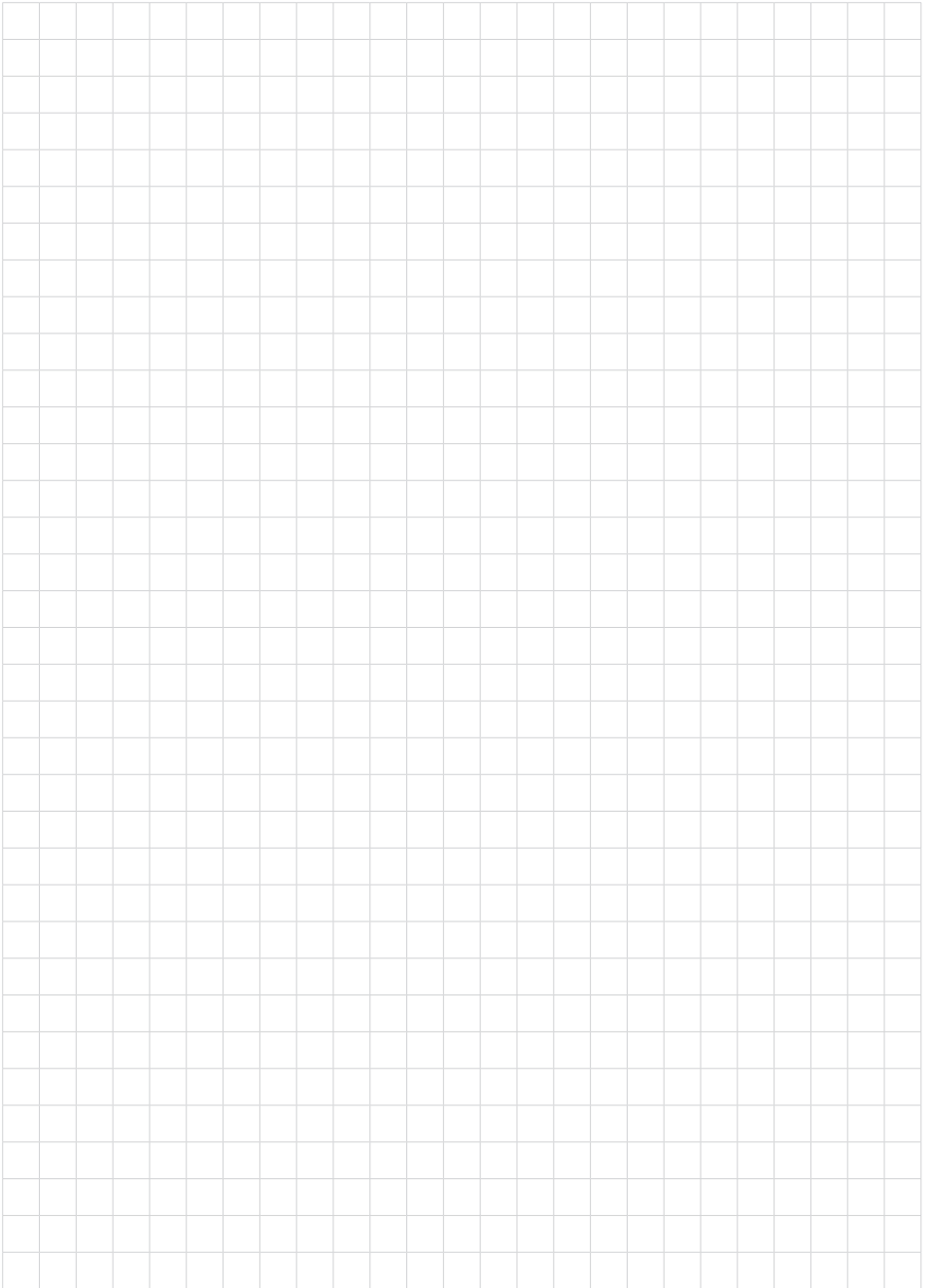

Printing date:

VEGA

All statements concerning scope of delivery, application, practical use and operating conditions of the sensors and processing systems correspond to the information available at the time of printing.

Subject to change without prior notice

© VEGA Grieshaber KG, Schiltach/Germany 2020



55511-EN-201120

VEGA Grieshaber KG
Am Hohenstein 113
77761 Schiltach
Germany

Phone +49 7836 50-0
Fax +49 7836 50-201
E-mail: info.de@vega.com
www.vega.com