

# Mounting instructions - Ship- building

## VEGAPULS 64

Cargo tanks: chemical, oil, multi-product,  
LPG, LNG tanker

Service tanks: hydraulic oil, waste water



Document ID: 54437



**VEGA**

## Contents

<b>1</b>	<b>General information</b> .....	<b>3</b>
1.1	General instructions .....	3
1.2	Type label.....	3
<b>2</b>	<b>Mounting, in general</b> .....	<b>5</b>
2.1	Suitable housing versions .....	5
2.2	Installation on deck with protective cover .....	5
2.3	Installation on deck without protective cover .....	6
<b>3</b>	<b>Mounting on a chemical tanker (free radiating)</b> .....	<b>7</b>
3.1	General information.....	7
3.2	Nozzle .....	7
3.3	Lateral distance.....	9
3.4	Bottom installations .....	11

# 1 General information

## 1.1 General instructions

This mounting instructions manual provides the necessary guidelines for correct mounting of radar sensors VEGAPULS 64 on ships.

The VEGAPULS 64 is suitable for the following applications:

- Cargo tanker (chemical, oil, multi-product, LPG, LNG tanks)
- Service tanks (hydraulic oil, wastewater tank)

The mounting instructions manual applies to the following sensors with ship approval:

- VEGAPULS 64

Only the above mentioned versions are suitable for the special requirements on ships. Take note of the type label of the sensor. "*Ship approval*" must be printed close to the "*Type approval mark*" (see also chapter "*Type label*"). You can find the type label outside on the instrument housing.

To ensure proper functioning of the instrument, take careful note of all the information in this mounting instructions manual.

Mount the VEGAPULS 64 exactly according to the instructions in this manual.

Read this manual before selecting the mounting position. Take note of existing installations and discuss the mounting with the shipyard technicians.

Make all necessary information on the mounting position and installation conditions available to the shipyard.

You can find further information on technical data or setup in the operating instructions of VEGAPULS 64. This manual comes with the instrument.



When using in hazardous areas take note of all relevant technical data and special regulations of the Ex-specific safety instructions of VEGAPULS 64 as well as possible devices that supply power. The approval documents are part of the scope of delivery for instruments with Ex approval.

## 1.2 Type label

The type label contains the most important data for identification and use of the instrument:

### Type label



Fig. 1: Layout of the type label (example)

- 1 Instrument type
- 2 Product code
- 3 Type approval mark
- 4 Power supply and signal output, electronics
- 5 Protection rating
- 6 Measuring range
- 7 Process and ambient temperature, process pressure
- 8 Material wetted parts
- 9 Serial number of the instrument
- 10 Data matrix code for VEGA Tools app
- 11 Symbol of the device protection class
- 12 Reminder to observe the instrument documentation

## 2 Mounting, in general

### 2.1 Suitable housing versions

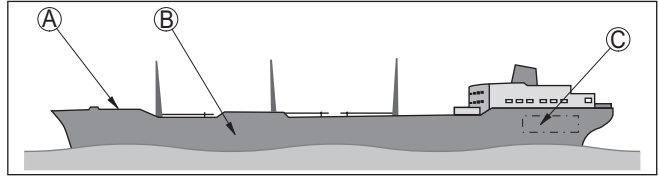

Fig. 2: Areas on a ship - side view

- A On deck
- B Below deck
- C Engine room

	Plastic housing	Aluminium housing	Stainless steel housing (precision casting)
On deck	No	No	Yes
Below deck	Yes	No	Yes
Engine room	Yes	No	Yes

Tab. 1: Suitable housings for different areas of the ship

### 2.2 Installation on deck with protective cover

	Housing	Protective cover closed	Protective cover vented
Plastic			
Aluminium die-casting			
Stainless steel housing 316L (IP68, 0.2 bar)			

Cable gland for cable diameters of 7 ... 12 mm. An additional seal for cable diameters of 10 ... 14 mm is included.

### Adapter for protective hose

## 2.3 Installation on deck without protective cover

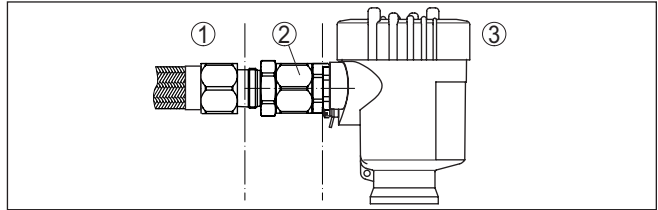

Fig. 3: Adapter for protective hose

- 1 Installation by shipyard
- 2 Adapter for protective hose - M20 x 1.5 to M24 x 1.5
- 3 Housing stainless steel, precision casting 316L, 0.2 bar with adapter for protective hose

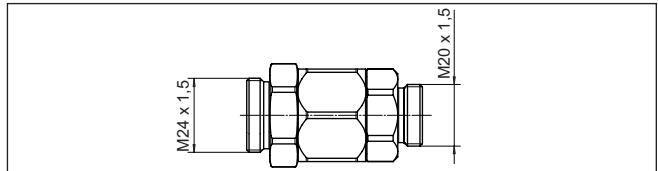

Fig. 4: Adapter for protective hose - M20 x 1.5 to M24 x 1.5

Cable gland for cable diameters of 13 mm, additional seal for cable diameters of 9 ... 11 mm is attached.

### Stainless steel housing IP68, 1 bar

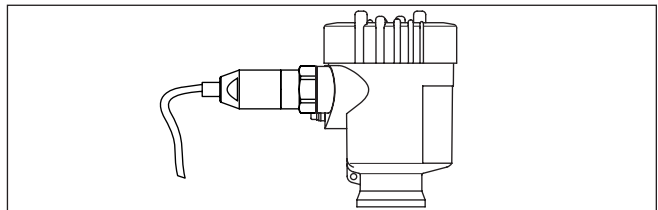

Fig. 5: Housing stainless steel, precision casting 316L IP68, 1 bar with VEGA cable outlet

Stainless steel housing IP68, 1 bar with cable outlet (PUR) and capillaries for pressure transmitters.

### 3 Mounting on a chemical tanker (free radiating)

#### 3.1 General information

The antenna of the free-radiating radar level measuring instrument VEGAPULS 64 emits short radar pulses that are reflected by the medium surface and picked up again by the antenna. Since not only the medium surface, but also any other surface within the radar beam reflects the microwaves, the mounting socket in particular, as well as any built-in fixtures on the sides and bottom of the tank, must be taken into account during installation on board.

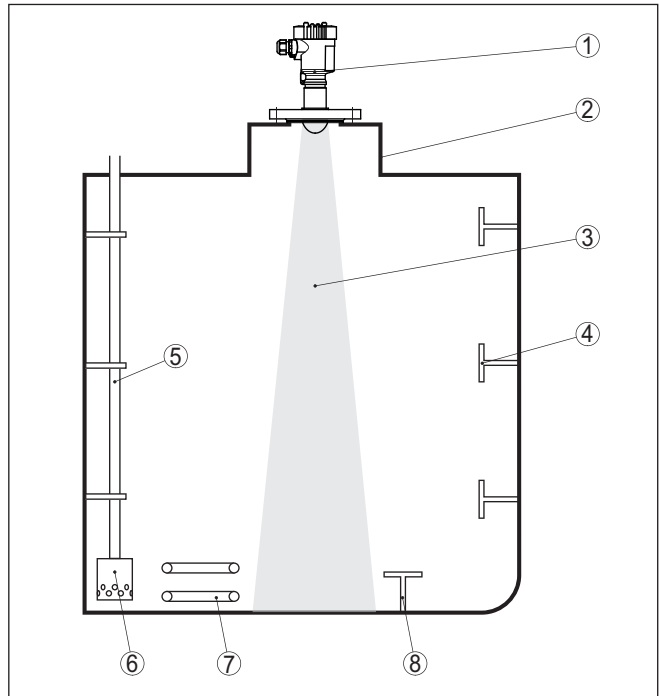

Fig. 6: Typical installation on a cargo tank

- 1 Radar sensor
- 2 VEGAPULS 64 nozzle
- 3 Radar beam
- 4 Bulkheads
- 5 Conveyor pipeline
- 6 Conveyor pump
- 7 Heating cables
- 8 Bulkheads

#### 3.2 Nozzle

Internal weld joints cause strong reflections. This impairs the measurement, hence the nozzle must only be welded from the outside.

**Mounting on DN80 or 3" nozzle**

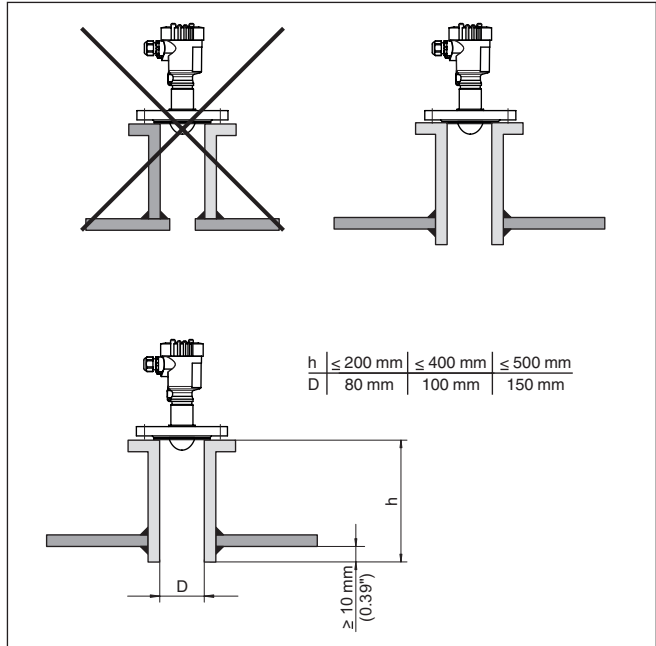

Fig. 7: Mounting on DN80 or 3" nozzle



**Mounting on a dome**

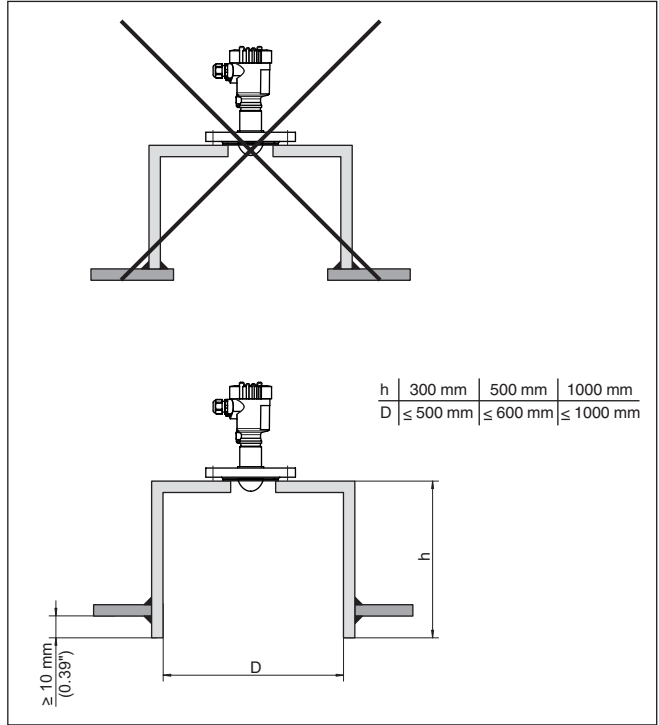

Fig. 8: Mounting on a dome

**3.3 Lateral distance**

To avoid measurement interference, maintain a minimum distance to internal vessel fixtures or the vessel wall.

**Min. distances to the vessel wall**

Fig. 9: Required min. distance to vessel wall depending on height

Vessel height h	5 m	10 m	15 m	20 m	25 m	30 m
Min. distance x with G $\frac{3}{4}$ antenna	0.7 m	1.3 m	2 m	2.6 m	3.3 m	3.9 m
Min. distance x with G1 $\frac{1}{2}$ antenna	0.3 m	0.7 m	1 m	1.4 m	1.7 m	2.1 m
Min. distance x with DN 50 flange antenna	0.3 m	0.5 m	0.8 m	1 m	1.3 m	1.6 m
Min. distance x with DN 80 flange antenna	0.2 m	0.3 m	0.5 m	0.7 m	0.9 m	1 m
Min. distance x with DN 80 plastic antenna	0.2 m	0.3 m	0.5 m	0.7 m	0.9 m	1 m

**Min. distance to lateral built-in fixtures**

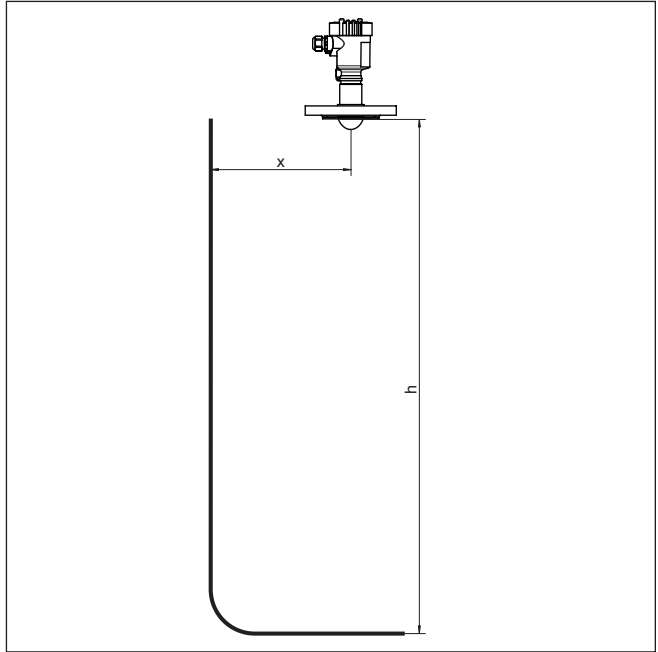
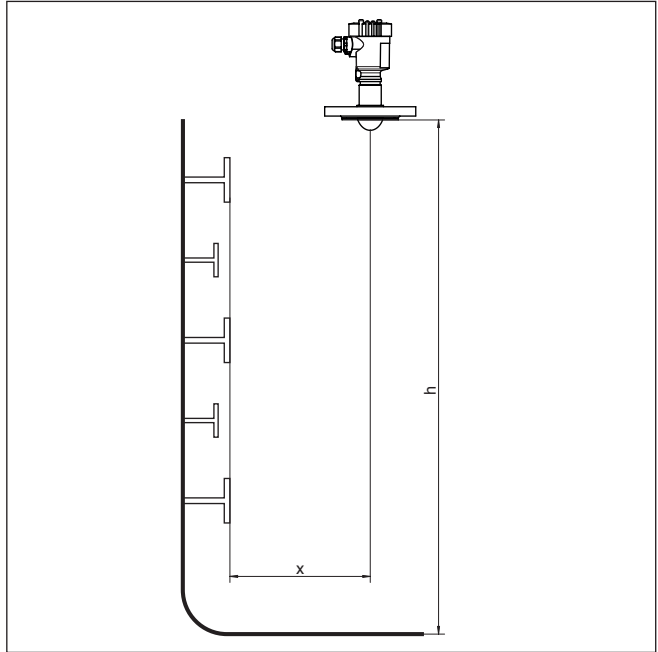

Fig. 10: Avoid interference from lateral installations

Vessel height h	5 m	10 m	15 m	20 m	25 m	30 m
Min. distance x with G¾ antenna	1 m	1.9 m	2.9 m	3.9 m	4.9 m	5.8 m
Min. distance x with G1½ antenna	0.8 m	1.7 m	2.5 m	3.3 m	4.2 m	5 m
Min. distance x with DN 50 flange antenna	0.4 m	0.9 m	1.3 m	1.7 m	2.2 m	2.6 m
Min. distance x with DN 80 flange antenna	0.3 m	0.5 m	0.8 m	1 m	1.3 m	1.6 m
Min. distance x with DN 80 plastic antenna	0.4 m	0.9 m	1.3 m	1.7 m	2.2	2.6 m

**3.4 Bottom installations**

To avoid measurement interference, make sure there are no fixtures or heating spirals within the range of the radar beam at the vessel bottom. If this is not possible, the sensor must be oriented as shown in the following examples.

**Required free space at tank bottom**

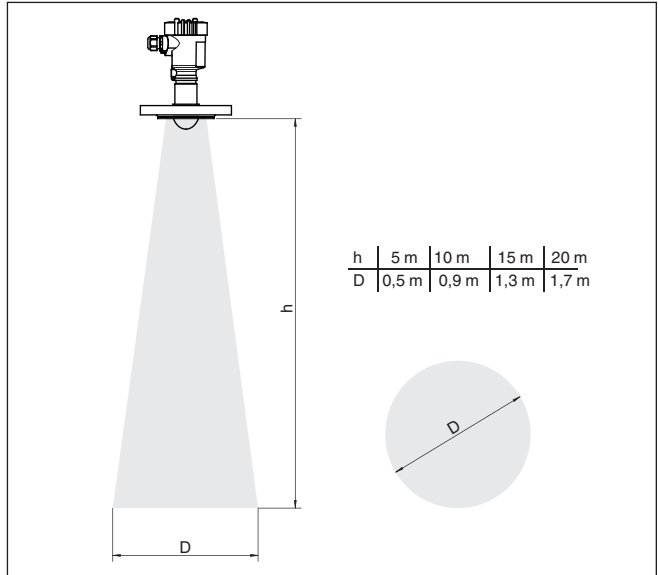
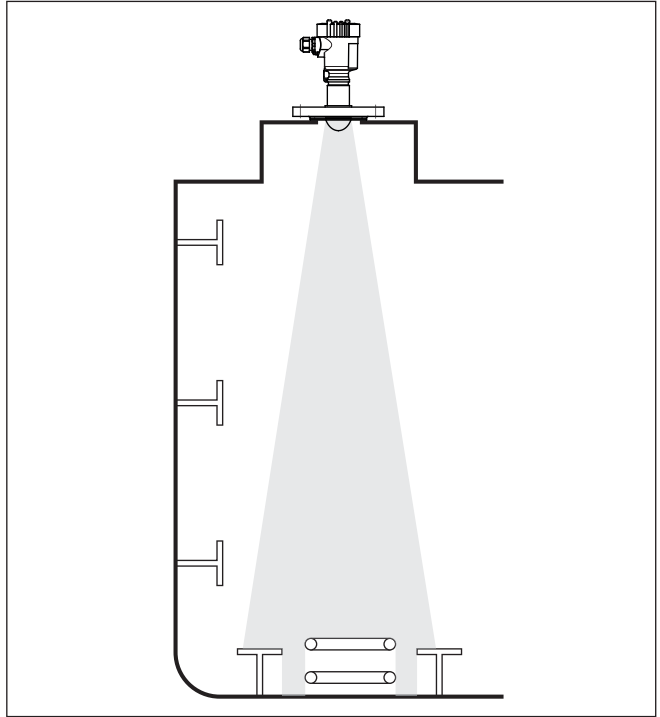

Fig. 11: Radar beam: Required free space at tank bottom depending on vessel height

**Examples of fixtures at bottom of tank**



*Fig. 12: Interfering tank bottom installations such as heating coils or bulkheads*

**Heating coils**

Direct the radar beam to a spot without heating coils. Modify the heating spirals in such a way that the required free space is created. If this is not possible, align the sensor so that the centre of the radar beam does not strike a heating coil.

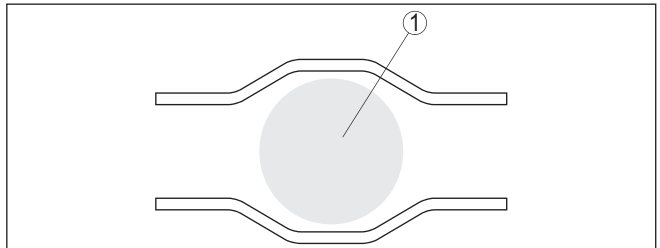

*Fig. 13: Modification of the heating coils*

1 Radar beam

## Orientation

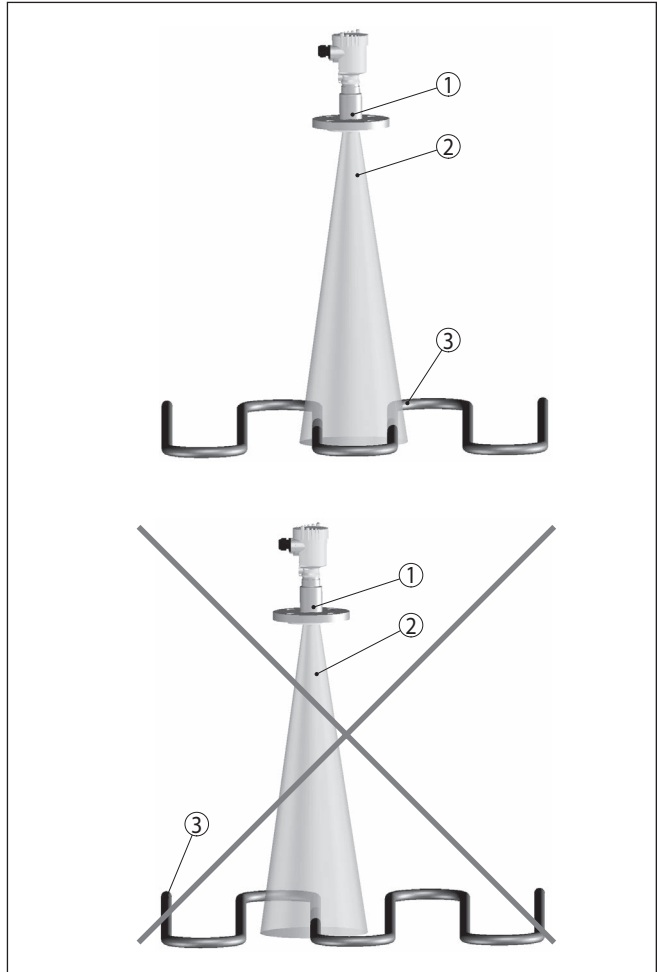

Fig. 14: Orientation: There must be no heating coils in the centre of the radar beam

- 1 VEGAPULS 64
- 2 Radar beam
- 3 Heating coils

**Note:**

Additional false echoes can result if the mounts of the heating coils are within the range of the radar beam. In such case, direct the radar beam to a spot without mounts.

**Bulkheads**

Direct the radar beam to a spot without bulkheads. If this is not possible, the bulkheads should be covered with angle plates. These ensure

that the radar signals are deflected to the side instead of reflected straight back to the sensor.

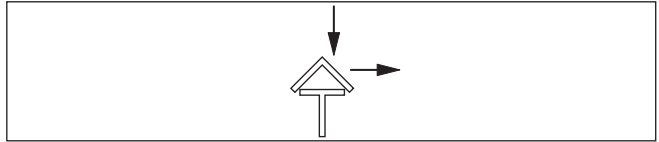

*Fig. 15: Bulkheads in the radar beam: Deflection of the radar beam by angle plates*

Printing date:

**VEGA**

All statements concerning scope of delivery, application, practical use and operating conditions of the sensors and processing systems correspond to the information available at the time of printing.

Subject to change without prior notice

© VEGA Grieshaber KG, Schiltach/Germany 2021



54437-EN-210727

VEGA Grieshaber KG  
Am Hohenstein 113  
77761 Schiltach  
Germany

Phone +49 7836 50-0  
E-mail: [info.de@vega.com](mailto:info.de@vega.com)  
[www.vega.com](http://www.vega.com)