

MOUNTING REFERENCE

SLOT FOR 5/16\"/>

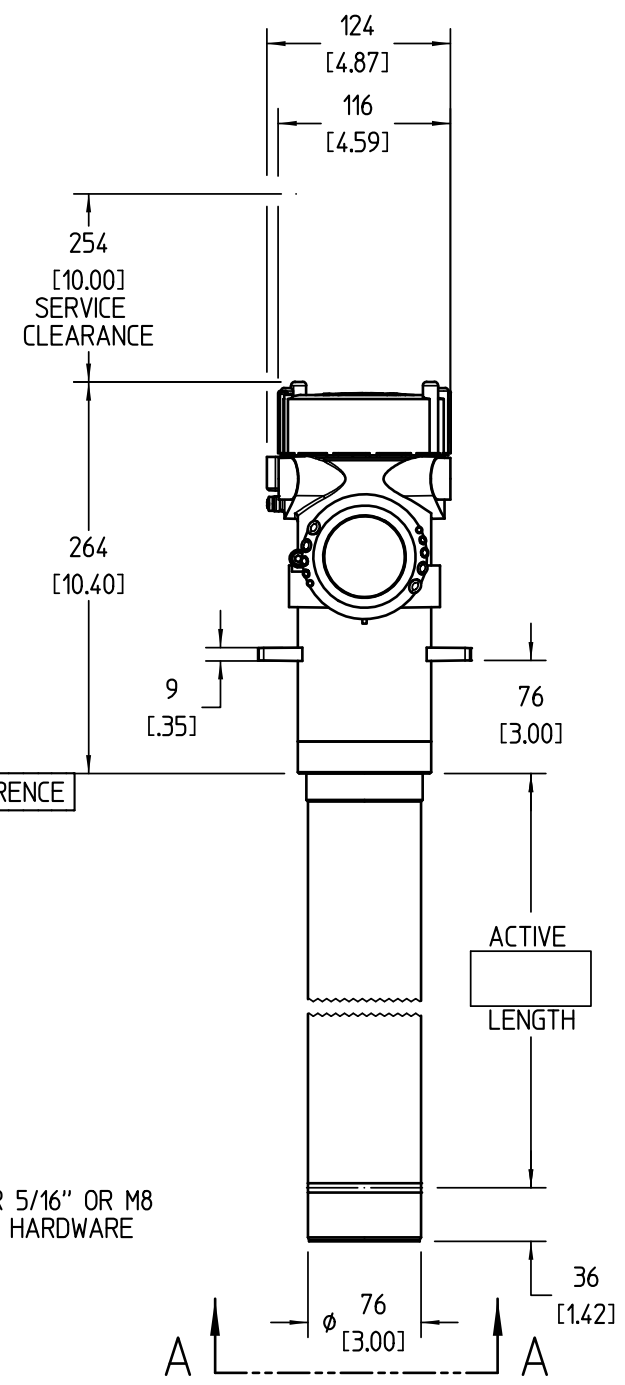

THIS DOCUMENT INCLUDES INFORMATION WHICH IS PROPRIETARY TO VEGA AMERICAS INC. NEITHER THIS DOCUMENT NOR THE INFORMATION DISCLOSED HEREIN SHALL BE USED OR DISCLOSED TO OTHERS FOR MANUFACTURING OR ANY OTHER PURPOSE EXCEPT AS SPECIFICALLY AUTHORIZED IN WRITING BY VEGA AMERICAS INC. THIS DOES NOT APPLY TO INFORMATION FURNISHED BY VENDORS OR OTHERS OUTSIDE VEGA AMERICAS INC.

Diese Zeichnung bleibt Eigentum der Firma VEGA Americas Inc. Sie darf ohne unsere Genehmigung weder kopiert, noch 3. Personen oder Konkurrenzfirmen mitgeteilt werden. ( § 2 Abs.1 Ziff.7 UrhG vom 09.09.1965 )

NOTES:  
1. DETECTOR SHOULD BE MOUNTED WHERE PROCESS MATERIAL OR OTHER FOREIGN MATTER CANNOT ACCUMULATE BETWEEN THE BELT AND SCINTILLATOR.

Passmaß/tol.dimens.		Abmaß/allowance		Änderung / revision		Änd. Nr. / ECN no.	Datum / Date	gezeichnet / freigegeben / drawn / checked
-		-		INITIAL RELEASE		26112	05.04.2016	grieshopc bruckere
Freimaß/toleranz general tolerance		gezeichnet drawn	Datum/Date	Name/Name	Benennung	Description		
-		freigegeben checked	05.04.2016	grieshopc	WEIGHTRAC 31	WEIGHTRAC 31		
-		Maßstab Scale	11.05.2016	shrebeb	Art.Nr. / Art.No.		MB6849	
-		Originalformat size of origin	-		Zchngs.-Nr. / Drawing No.		MB6849	
-		Blatt / Sheet	-		Var.Fam.: WT31.XXXXXXXXXXX		Var.Fam.2:WEIGHTRAC31	
-		1 von 1	-		Teil ähnl. / sim. part		Ersatz f./replacement f.	
-		-		VEGA		Arb.Anw. / work.instr.		DIMENSIONS/BENASSUNGEN: mm (INCHES)
-		-		VEGA Americas Inc. 4241 Allendorf Drive Cincinnati, Ohio 45209 USA		-		