

Operating Instructions

Double channel separator for 4 ... 20 mA sensors

VEGATRENN 152



Document ID: 50783



VEGA

Contents

1	About this document	3
1.1	Function	3
1.2	Target group	3
1.3	Symbols used.....	3
2	For your safety	4
2.1	Authorised personnel	4
2.2	Appropriate use.....	4
2.3	Warning about incorrect use.....	4
2.4	General safety instructions	4
2.5	Installation and operation in the USA and Canada	5
2.6	Safety instructions for Ex areas	5
3	Product description	6
3.1	Configuration.....	6
3.2	Principle of operation.....	6
3.3	Adjustment	6
3.4	Packaging, transport and storage.....	7
4	Mounting	8
4.1	General instructions	8
5	Connecting to power supply	9
5.1	Preparing the connection	9
5.2	Connection procedure.....	10
5.3	Wiring plan	11
6	Setup	12
6.1	Adjustment system.....	12
6.2	Adjustment elements.....	12
7	Diagnostics and servicing	14
7.1	Maintenance	14
7.2	Rectify faults.....	14
7.3	How to proceed if a repair is necessary.....	14
8	Dismount	16
8.1	Dismounting steps.....	16
8.2	Disposal	16
9	Certificates and approvals	17
9.1	Approvals for Ex areas	17
9.2	Conformity.....	17
9.3	SIL conformity (optional)	17
9.4	Environment management system	17
10	Supplement	18
10.1	Technical data	18
10.2	Dimensions	20
10.3	Industrial property rights.....	21
10.4	Trademark	21

1 About this document

1.1 Function

This instruction provides all the information you need for mounting, connection and setup as well as important instructions for maintenance, fault rectification, safety and the exchange of parts. Please read this information before putting the instrument into operation and keep this manual accessible in the immediate vicinity of the device.

1.2 Target group

This instruction manual is directed to trained personnel. The contents of this manual must be made available to the qualified personnel and implemented.

1.3 Symbols used



Document ID

This symbol on the front page of this instruction refers to the Document ID. By entering the Document ID on www.vega.com you will reach the document download.



Information, note, tip: This symbol indicates helpful additional information and tips for successful work.



Note: This symbol indicates notes to prevent failures, malfunctions, damage to devices or plants.



Caution: Non-observance of the information marked with this symbol may result in personal injury.



Warning: Non-observance of the information marked with this symbol may result in serious or fatal personal injury.



Danger: Non-observance of the information marked with this symbol results in serious or fatal personal injury.



Ex applications

This symbol indicates special instructions for Ex applications.



List

The dot set in front indicates a list with no implied sequence.



Sequence of actions

Numbers set in front indicate successive steps in a procedure.



Disposal

This symbol indicates special instructions for disposal.

2 For your safety

2.1 Authorised personnel

All operations described in this documentation must be carried out only by trained and authorized personnel.

During work on and with the device, the required personal protective equipment must always be worn.

2.2 Appropriate use

VEGATRENN 152 is an [EEx ia] separator without separate power supply for connection of 4 ... 20 mA/HART sensors in two-wire version.

You can find detailed information about the area of application in chapter "*Product description*".

Operational reliability is ensured only if the instrument is properly used according to the specifications in the operating instructions manual as well as possible supplementary instructions.

2.3 Warning about incorrect use

Inappropriate or incorrect use of this product can give rise to application-specific hazards, e.g. vessel overfill through incorrect mounting or adjustment. Damage to property and persons or environmental contamination can result. Also, the protective characteristics of the instrument can be impaired.

2.4 General safety instructions

This is a state-of-the-art instrument complying with all prevailing regulations and directives. The instrument must only be operated in a technically flawless and reliable condition. The operating company is responsible for the trouble-free operation of the instrument. When measuring aggressive or corrosive media that can cause a dangerous situation if the instrument malfunctions, the operating company has to implement suitable measures to make sure the instrument is functioning properly.

The safety instructions in this operating instructions manual, the national installation standards as well as the valid safety regulations and accident prevention rules must be observed.

For safety and warranty reasons, any invasive work on the device beyond that described in the operating instructions manual may be carried out only by personnel authorised by us. Arbitrary conversions or modifications are explicitly forbidden. For safety reasons, only the accessory specified by us must be used.

To avoid any danger, the safety approval markings and safety tips on the device must also be observed.

2.5 Installation and operation in the USA and Canada

This information is only valid for USA and Canada. Hence the following text is only available in the English language.

Installations in the US shall comply with the relevant requirements of the National Electrical Code (NEC - NFPA 70) (USA).

Installations in Canada shall comply with the relevant requirements of the Canadian Electrical Code (CEC Part I) (Canada).

2.6 Safety instructions for Ex areas

For applications in hazardous areas (Ex), only devices with corresponding Ex approval may be used. Observe the Ex-specific safety instructions. These are an integral part of the device documentation and are enclosed with every device with Ex approval.

3 Product description

3.1 Configuration

Scope of delivery

The scope of delivery encompasses:

- VEGATRENN 152

The further scope of delivery encompasses:

- Documentation
 - Ex-specific "*Safety instructions*" (with Ex versions)
 - If necessary, further certificates



Information:

Optional instrument features are also described in this instructions manual. The respective scope of delivery results from the order specification.

Type label

The type label contains the most important data for identification and use of the instrument:

- Instrument type
- Information about approvals
- Configuration information
- Technical data
- Serial number of the instrument
- QR code for device identification
- Manufacturer information

Documents and software

To find order data, documents or software related to your device, you have the following options:

- Move to "www.vega.com" and enter in the search field the serial number of your instrument.
- Scan the QR code on the type label.
- Open the VEGA Tools app and enter the serial number under "*Documentation*".

3.2 Principle of operation

Application area

VEGATRENN 152 is a double channel [EEx ia] separator for connection of two 4 ... 20 mA/HART sensors in two-wire version. A separate power supply is not necessary. As an associated electrical device, it ensures a galvanic separation between sensor circuit and processing circuit and thus between Ex and non-Ex areas.

Functional principle

The current signal from the sensor (4 ... 20 mA) is transferred linearly and galvanically separated to the output. The VEGATRENN 152 is suitable for bidirectional transmission of HART signals. The HART signal can be tapped separately for each channel via the front-mounted HART communication sockets or the terminals.

3.3 Adjustment

No adjustment or configuration of VEGATRENN 152 is necessary. A parameter adjustment of the connected sensors can be carried out

via the HART communication sockets behind the hinged front cover. Adjustment of the connected sensors is carried out preferably via a Windows PC with a parameter adjustment software such as PACTware and corresponding DTM. A VEGACONNECT interface adapter or a HART modem is necessary for connecting the PC.

3.4 Packaging, transport and storage

Packaging

Your instrument was protected by packaging during transport. Its capacity to handle normal loads during transport is assured by a test based on ISO 4180.

The packaging consists of environment-friendly, recyclable cardboard. For special versions, PE foam or PE foil is also used. Dispose of the packaging material via specialised recycling companies.

Transport

Transport must be carried out in due consideration of the notes on the transport packaging. Nonobservance of these instructions can cause damage to the device.

Transport inspection

The delivery must be checked for completeness and possible transit damage immediately at receipt. Ascertained transit damage or concealed defects must be appropriately dealt with.

Storage

Up to the time of installation, the packages must be left closed and stored according to the orientation and storage markings on the outside.

Unless otherwise indicated, the packages must be stored only under the following conditions:

- Not in the open
 - Dry and dust free
 - Not exposed to corrosive media
 - Protected against solar radiation
 - Avoiding mechanical shock and vibration
-
- Storage and transport temperature see chapter "*Supplement - Technical data - Ambient conditions*"
 - Relative moisture 20 ... 85 %

Storage and transport temperature

4 Mounting

4.1 General instructions

Mounting options

VEGATRENN 152 is designed for carrier rail mounting (top hat rail 35 x 7.5 according to DIN EN 50022/60715). Due to its protection rating of IP20, the instrument is suitable for mounting in switching cabinets. It can be mounted horizontally and vertically.



VEGATRENN 152 is a corresponding, intrinsically safe equipment and must not be installed in hazardous areas of zone 0/1. A safe operation is only ensured if the operating instructions and EU type approval certificate are observed. VEGATRENN 152 must not be opened.

A distance of 50 mm to the intrinsically safe terminals must be ensured when mounting.

Ambient conditions

The instrument is suitable for standard and extended ambient conditions acc. to DIN/EN/BS EN/IEC/ANSI/ISA/UL/CSA 61010-1.

Make sure that the environmental and ambient conditions specified in chapter "*Technical data*" are maintained.

5 Connecting to power supply

5.1 Preparing the connection

Safety instructions

Always keep in mind the following safety instructions:



Warning:

Connect only in the complete absence of line voltage.

- Connect only in the complete absence of line voltage
- If overvoltage surges are expected, overvoltage arresters should be installed

Safety instructions for Ex applications



In hazardous areas you must take note of the respective regulations, conformity and type approval certificates of the sensors and power supply units.

Voltage supply

Voltage supply via the 4 ... 20 mA signal cable (loop-powered). A separate auxiliary voltage is hence not necessary. The current input of the processing, e.g. a PLC or a display instrument must be active, i.e. providing the voltage supply of the sensors and the VEGATRENN 152. You can find details of the voltage supply in chapter "*Technical data*".

Connection cable

The voltage supply of VEGATRENN 152 is connected with standard cable according to the national installation standards.

Make sure that the cable used has the required temperature resistance and fire safety for max. occurring ambient temperature

The sensors are connected with standard two-wire cable without shielding. If electromagnetic interference is expected which is above the test values of EN 61326 for industrial areas, shielded cable should be used.

Cable screening and grounding

Connect the cable shielding on both ends to ground potential. In the sensor, the shielding must be connected directly to the internal ground terminal. The ground terminal on the outside of the sensor housing must be connected to the potential equalisation (low impedance).

If potential equalisation currents are expected, the connection on the processing side must be made via a ceramic capacitor (e. g. 1 nF, 1500 V). The low-frequency potential equalisation currents are thus suppressed, but the protective effect against high frequency interference signals remains.

Connection cable for Ex applications



Take note of the corresponding installation regulations for Ex applications. In particular, make sure that no potential equalisation currents flow over the cable screen. In case of grounding on both sides this can be achieved by the use of a capacitor or a separate potential equalisation described above.

HART communication

The instrument is equipped with communication sockets in the front for connection of a VEGACONNECT or another HART handheld as well as an integrated HART resistor.

If the resistance of the connected processing system is less than $230\ \Omega$, the digital adjustment signal is extremely damped or short-circuited. Digital communication with the PC is then no longer possible. With low impedance processing systems, a resistor of approx. $230\ \Omega$ must be looped into the 4 ... 20 mA cable. This resistor is already integrated in VEGATRENN 152 and can be chosen through the selection of the respective terminals.

i **Information:**

When using a HART resistor, keep in mind that there is an additional voltage loss. You can find details in chapter "*Technical data*".

No additional resistor is required in the sensor circuit for direct connection of a HART-Master. When connecting a VEGADIS 82, the communication resistor in the VEGADIS 82 must be deactivated.

i **Note:**

It is possible to connect up to five HART sensors to one VEGATRENN 152. Several VEGATRENN can also be connected on the evaluation side parallel to a PLC input, e.g. but the maximum number of connectable HART sensors is limited to a total of five because all interconnected VEGATRENN form a common bus.

5.2 Connection procedure

The pluggable terminals can be removed as needed to allow more convenient connection. To make the electrical connection, proceed as follows:

1. Mount the instrument as described in the previous chapter
2. Connect sensor cable 2 to terminal 4/5, and where applicable, connect the shielding
3. Connect sensor cable 1 to terminal 1/2, and where applicable, connect the shielding
4. Connect processing circuit 2, e.g. from PLC to terminal 14/15 or 13/15 (with HART resistor), and shielding, if necessary
5. Connect processing circuit 1, e.g. from PLC to terminal 11/12 or 10/12 (with HART resistor), and shielding, if necessary

The electrical connection is finished.

i **Note:**

If several sensors should be connected in HART multidrop mode, a respective HART address must be assigned to each sensor before connecting to VEGATRENN 152.

5.3 Wiring plan

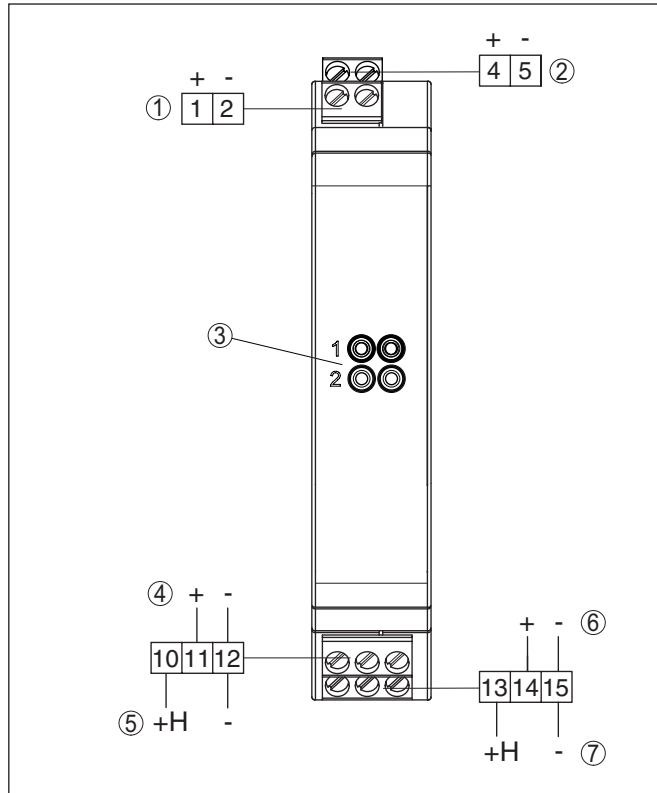

- 1 Sensor circuit 1 (4 ... 20 mA/HART, Ex area)
- 2 Sensor circuit 2 (4 ... 20 mA/HART, Ex area)
- 3 HART communication sockets for connection of a HART handheld, e.g. a VEGACONNECT
- 4 Processing circuit 1 (4 ... 20 mA/HART, passive output)
- 5 Processing circuit 1 (4 ... 20 mA/HART, passive output with looped HART resistor)
- 6 Processing circuit 2 (4 ... 20 mA/HART, passive output)
- 7 Processing circuit 2 (4 ... 20 mA/HART, passive output with looped HART resistor)



Information:

The connection terminals can be detached towards the front, if necessary. This can be useful when working in tight spaces or when exchanging an instrument.

6 Setup

6.1 Adjustment system

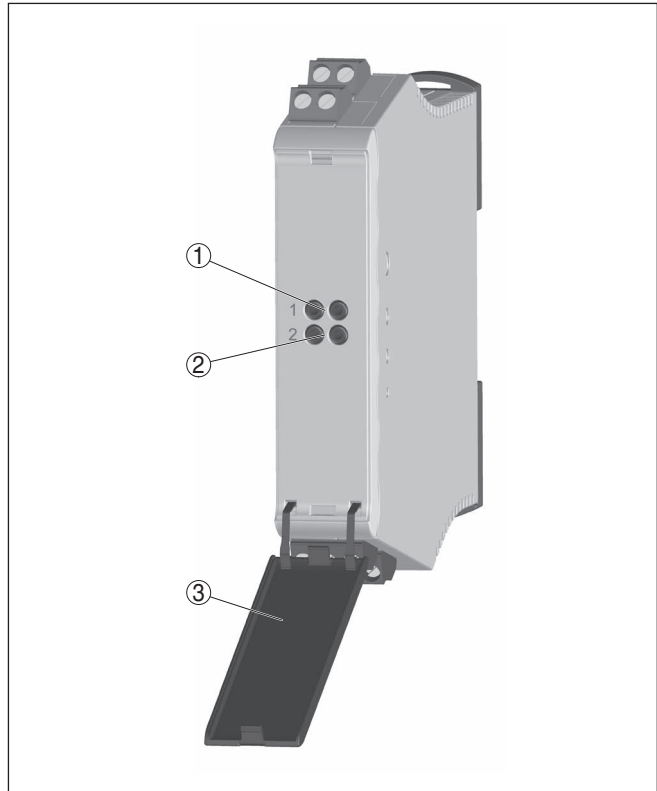

Fig. 1: Display and adjustment elements

- 1 HART communication sockets, channel 1
- 1 HART communication sockets, channel 2
- 3 Hinged front cover

6.2 Adjustment elements

Front cover

The adjustment elements are located under a hinged front cover. To open it, use a small screwdriver in conjunction with the slot on the upper side of the front cover. To close it, push the cover at bottom and top firmly onto the front cover until you hear the two retaining clips snap in.

HART communication sockets

No adjustment or configuration of VEGATRENN 152 is necessary. Via the HART communication sockets, parameter adjustment of the connected HART sensors can be carried out without interrupting the measuring circuit. The resistor (230 Ω) required for this purpose is already integrated in VEGATRENN 152 when connecting the termi-

nals 10/12 (channel 1) or 13/15 (channel 2). The adjustment of the connected sensor is carried out via a Windows PC with a parameter adjustment software such as e.g. PACTware and corresponding DTM.

7 Diagnostics and servicing

7.1 Maintenance

Maintenance

If the device is used properly, no special maintenance is required in normal operation.

Cleaning

The cleaning helps that the type label and markings on the instrument are visible.

Take note of the following:

- Use only cleaning agents which do not corrode the housings, type label and seals
- Use only cleaning methods corresponding to the housing protection rating

7.2 Rectify faults

Reaction when malfunction occurs

The operator of the system is responsible for taking suitable measures to rectify faults.

Causes of malfunction

The device offers maximum reliability. Nevertheless, faults can occur during operation. These may be caused by the following, e.g.:

- Measured value from sensor not correct
- Voltage supply
- Interference in the cables

Fault rectification

The first measure to be taken is to check the input/output signal as well as the power supply. In many cases, the causes can be determined and faults can be quickly rectified.

Reaction after fault rectification

Depending on the reason for the fault and the measures taken, the steps described in chapter "Setup" must be carried out again or must be checked for plausibility and completeness.

24 hour service hotline

Should these measures not be successful, please call in urgent cases the VEGA service hotline under the phone no. **+49 1805 858550**.

The hotline is also available outside normal working hours, seven days a week around the clock.

Since we offer this service worldwide, the support is provided in English. The service itself is free of charge, the only costs involved are the normal call charges.

7.3 How to proceed if a repair is necessary

On our homepage you will find detailed information on how to proceed in the event of a repair.

So that we can carry out the repair quickly and without queries, generate a instrument return form there with the data of your device.

You will need:

- The serial number of the instrument
- A short description of the problem

- Details of the medium

Print the generated instrument return form.

Clean the instrument and pack it damage-proof.

Send the printed instrument return form and possibly a safety data sheet together with the device.

You will find the address for the return on the generated instrument return form.

8 Dismount

8.1 Dismounting steps

Take note of chapters "*Mounting*" and "*Connecting to voltage supply*" and carry out the listed steps in reverse order.

8.2 Disposal



Pass the instrument on to a specialised recycling company and do not use the municipal collecting points.

Remove any batteries in advance, if they can be removed from the device, and dispose of them separately.

If personal data is stored on the old device to be disposed of, delete it before disposal.

If you have no way to dispose of the old instrument properly, please contact us concerning return and disposal.

9 Certificates and approvals

9.1 Approvals for Ex areas

Approved versions for use in hazardous areas are available or in preparation for the device or the device series.

You can find the relevant documents on our homepage.

9.2 Conformity

The device complies with the legal requirements of the applicable country-specific directives or technical regulations. We confirm conformity with the corresponding labelling.

The corresponding conformity declarations can be found on our homepage.

9.3 SIL conformity (optional)

Instruments with SIL option fulfill the requirements of functional safety according to IEC 61508. You can find further information in the supplied Safety Manual.

9.4 Environment management system

Protection of the environment is one of our most important duties. That is why we have introduced an environment management system with the goal of continuously improving company environmental protection. The environment management system is certified according to DIN EN ISO 14001.

Help us to meet these requirements and observe the environmental instructions in the chapters "*Packaging, transport and storage*", "*Disposal*" of this instructions manual.

10 Supplement

10.1 Technical data

Note for approved instruments

The technical data in the respective safety instructions are valid for approved instruments (e.g. with Ex approval). In some cases, these data can differ from the data listed herein.

All approval documents can be downloaded from our homepage.

General data

Series	Module unit for mounting on carrier rails 35 x 7.5 acc. to EN 50022/60715
Weight	150 g (5.29 oz)
Housing material	Polycarbonate PC-FR
Connection terminals	
– Type of terminal	Screw terminal
– Wire cross-section	0.25 mm ² (AWG 23) ... 2.5 mm ² (AWG 12)

Voltage supply

Operating voltage	15 ... 35 V DC (loop-powered) ¹⁾
-------------------	---

Sensor circuit

Number of sensors	2 x 4 ... 20 mA/HART (5 x HART multidrop)
Input type	Active (sensor power supply by VEGATRENN 152)
Terminal voltage	16 ... 10 V DC at 4 ... 20 mA
Terminal voltage with operating voltage > 19 V	
– at 4 mA	> 14.5 V DC
– at 20 mA	> 14 V DC
Voltage loss with 15 V operating voltage	
– at 4 mA	< 3 V
– at 20 mA	< 5 V
Off-load voltage	< 17 V
Short-circuit current	≤ 27 mA
Residual ripple	< 20 mV RMS

Processing circuit

Quantity	2 x 4 ... 20 mA/HART
Type of output	Passive
Operating voltage	15 ... 35 V DC
Residual ripple of the output current	< 40 µA RMS
Current without connected sensor	< 500 µA

¹⁾ Without internal HART resistor (when connecting to terminal 11/12 or terminal 14/15)

Deviation

Offset	< 80 μ A with 25 °C (77 °F)
Reference conditions	Calibration temperature 25 °C (77 °F)
Linearity	\leq 0.15 %
Influence of the ambient temperature	
– In the range of +20 ... +60 °C (+68 ... +140 °F)	< 0.2 %
– In the range of -20 ... +20 °C (-4 ... +68 °F)	< 0.3 %
Deviation due to strong, high-frequency electromagnetic fields (EN 61326)	< 0.5 %

Integrated HART resistor

Resistance value	232 Ω
------------------	--------------

Ambient conditions

Ambient temperature at the installation site of the instrument	-20 ... +60 °C (-4 ... +140 °F)
Storage and transport temperature	-40 ... +70 °C (-40 ... +158 °F)
Relative humidity	< 96 %

Mechanical environmental conditions

Vibrations (oscillations)	Class 4M4 acc. to IEC 60721-3-4 (1 g, 4 ... 200 Hz)
Impacts (mechanical shock)	Class 6M4 acc. to IEC 60721-3-6 (10 g/11 ms, 30 g/6 ms, 50 g/2.3 ms)

Electrical protective measures

Protection rating	IP20
Protection class	II
Pollution degree	2

Measures for electrical separation

Reliable separation according to VDE 0106 part 1 between all circuits	
– Reference voltage	253 V
– Insulation resistance	2.2 kV

Approvals

Instruments with approvals can have different technical specifications depending on the version. For that reason the associated approval documents of these instruments have to be carefully noted. They are part of the delivery or can be downloaded by entering the serial number of your instrument into the search field under www.vega.com as well as in the general download area.

10.2 Dimensions

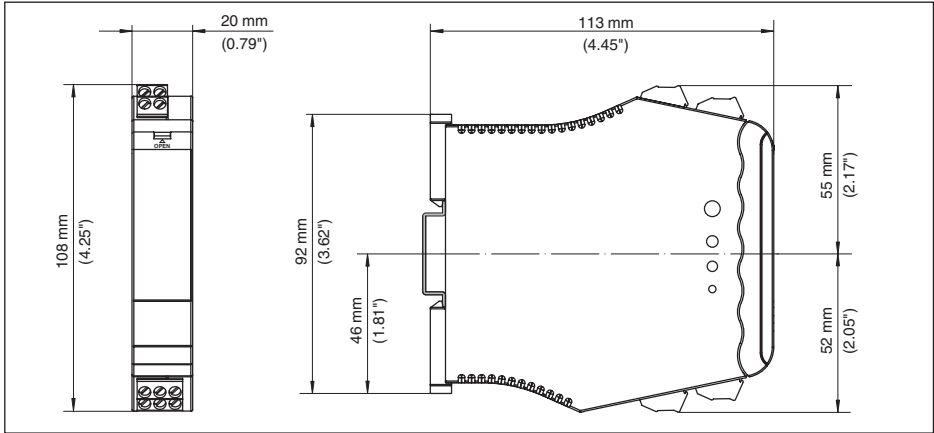

Fig. 2: Dimensions VEGATRENN 152

10.3 Industrial property rights

VEGA product lines are global protected by industrial property rights. Further information see www.vega.com.

VEGA Produktfamilien sind weltweit geschützt durch gewerbliche Schutzrechte.

Nähere Informationen unter www.vega.com.

Les lignes de produits VEGA sont globalement protégées par des droits de propriété intellectuelle. Pour plus d'informations, on pourra se référer au site www.vega.com.

VEGA lineas de productos están protegidas por los derechos en el campo de la propiedad industrial. Para mayor información revise la pagina web www.vega.com.

Линии продукции фирмы ВЕГА защищаются по всему миру правами на интеллектуальную собственность. Дальнейшую информацию смотрите на сайте www.vega.com.

VEGA系列产品在全球享有知识产权保护。

进一步信息请参见网站www.vega.com。

10.4 Trademark

All the brands as well as trade and company names used are property of their lawful proprietor/originator.

INDEX**C**

Cable screening 9
Carrier rail 8
Causes of malfunction 14
Connection 11
Connection cable 9
Connection terminals 10

D

Documentation 6
DTM 6, 12

G

Grounding 9

H

HART 6
HART communication 6, 9, 12
HART resistance 9, 12

L

Load 9

P

PACTware 6, 12
Potential equalisation 9
Protection rating 8

Q

QR code 6

R

Repair 14

S

Serial number 6
Service hotline 14
SIL 17

T

Type label 6

V

VEGACONNECT 9
Voltage supply 9



Printing date:

VEGA

All statements concerning scope of delivery, application, practical use and operating conditions of the sensors and processing systems correspond to the information available at the time of printing.

Subject to change without prior notice

© VEGA Grieshaber KG, Schiltach/Germany 2024



50783-EN-240216

VEGA Grieshaber KG
Am Hohenstein 113
77761 Schiltach
Germany

Phone +49 7836 50-0
E-mail: info.de@vega.com
www.vega.com