

Supplementary instructions

Air cooling - FIBERTRAC 31

Active air cooling system for radiometric sensors

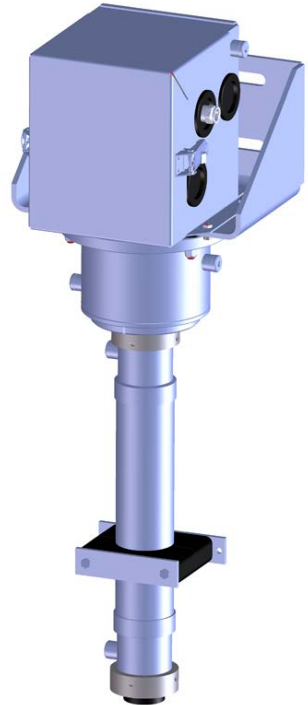

Document ID: 50339



VEGA

Contents

1	Product description	3
1.1	Configuration	3
2	Mounting	5
3	Replacement parts	18
3.1	Available spare parts - air cooling	18
4	Supplement	19
4.1	Technical data	19
4.2	Dimensions	21

1 Product description

1.1 Configuration

The active air cooling system is suitable for radiometric sensors of series FIBERTRAC 31.

The air cooling system consists of several modules.

Housing cooling box (A) The housing cooling box is placed above the instrument housing and enables cooling of the instrument housing.

Housing cooling (B) The cooling module for the housing is also cooled by the housing cooling box (A).

Scintillator cooling (C) The flexible cooling module for the scintillator cools the active measuring part of the sensor.

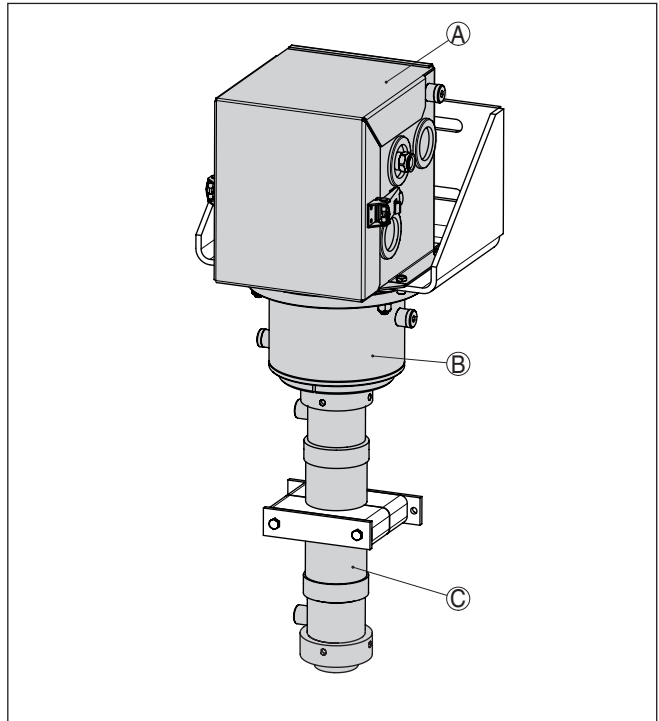

Fig. 1: Active air cooling system with fastening bracket

- A Housing cooling box
- B Housing cooling
- C Scintillator cooling (flexible)

Scope of delivery

The following parts belong to the scope of delivery of the air cooling system:

- Scintillator cooling hose (1 piece)
- Flange, sectioned (2 pieces)
- Hexagon socket screw M5 x 12 (6 pieces)
- Hexagon socket screw M5 x 14 (6 pieces)
- Spring ring for M5 (6 pieces)
- Sealing ring \varnothing 42 x 6 mm (2 pieces)
- Compression nut, top (1 piece)
- Compression nut, bottom (1 piece)
- Mounting clamp (quantity depending on sensor length)
- Fastening bracket
- Housing cooling box with detachable lid
- Isolating sleeve (6 pieces)
- Fixing screw M8 x 35 (2 pieces)
- Fixing screw M8 x 40 (4 pieces)
- Washer for M8 (10 pieces)
- Spring ring for M8 (2 pieces)
- Hexagon nut M8, self-locking (4 pieces)
- Eddy current cooler (type FOS 208SS 25 HVE BSP) for housing cooling box
- Vortex cooler (type FOS 208SS 35 HVE BSP) for scintillator cooling
- Blind plug $\frac{1}{4}$ " (3 pcs.)
- NPT threaded adapter for vortex cooler (optional)
- Hook wrench size 68 - 75, DIN 1810, Form B

i **Information:**

When the sensor is ordered with cooling, the sensor and the air cooling system are shipped pre-assembled.

If the air cooling system is ordered later, you have to mount it on the sensor yourself.

You can find further information in chapter "*Mounting*".

2 Mounting

Operating instructions

Mounting preparations

Take note of the operating instructions manuals of the corresponding radiometric sensors and the source holder.



Warning:

During all mounting and dismounting work, the source container must be in switch position "OFF" and secured by a lock.

Carry out all work within the shortest possible time and at the largest possible distance. Provide suitable shielding.

Avoid risk to other persons by taking suitable measures (e.g. safety fence, etc.).

Mounting may only be carried out by authorized, qualified personnel who are monitored for radiation exposure according to local laws or the handling permit. Take note of the specifications in the handling permit. Also take the local conditions into account.



Caution:

The cooling system is used in areas with high temperatures. Therefore, use temperature-resistant cable and install it in such a way that contact with hot components is avoided.

General mounting instructions



Information:

When the sensor is ordered with cooling, the sensor and the air cooling system are shipped pre-assembled.

If the air cooling system is ordered later, you have to mount it on the sensor yourself.

Required tools:

- Hook wrench size 68 - 75, DIN 1810, Form B - for screwing on the scintillator cooling hose (comes with the air cooling system)
- Allen key size 4 - for the bisectonal holding flange
- Fork wrench SW10 mm - for the mounting clip
- Fork wrench SW13 mm (2 pieces) - for the housing cooling
- Fork wrench SW19 mm (2 pcs.) - for vortex coolers
- Acid-free grease - to screw in the compression nuts more easily

Take note of the following general mounting instructions:

- First of all, mount the fastening bracket and the housing cooling, and then the sensor.
- The small lid of the instrument housing must point to the front after mounting the fastening bracket (x)
- The sensor together with the air cooling system is very heavy. Use a suitable lifting device for mounting, e.g. a hoisting sling
- To avoid penetration of moisture and dirt, you should remove the protective caps of the connection openings just before connection

Mounting

1. Place the isolating sleeves (4) between the housing cooling (5) and the fastening bracket (1).

Mount the fastening bracket

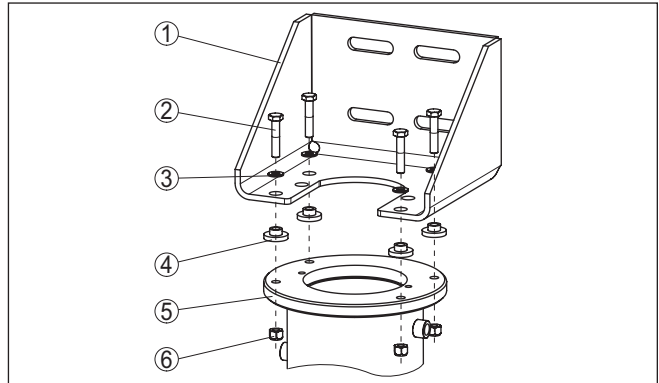

Fig. 2: Housing cooling with mounted sensor

- 1 Fastening bracket
- 2 Hexagon screw M8 (4 pieces)
- 3 Washer for M8 (4 pieces)
- 4 Isolating sleeve (4 pieces)
- 5 Housing cooling
- 6 Hexagon nut M8, self-locking (2 pcs.)

2. Place the fastening bracket (1) onto the housing cooling (5). Make sure that the cooling air connections point in a suitable direction. Rotating the fastening bracket later (1) is very difficult.
3. Connect the fastening bracket (1) with the housing cooling (5) according to the illustration and tighten the screws (2, 6) with a torque of 15 Nm (11.06 lbf ft). Provide counterforce with a second fork wrench.

Inserting the sensor

1. Insert the sensor into the housing cooling.
The small lid of the instrument housing must point to the front after mounting on the fastening bracket (x).

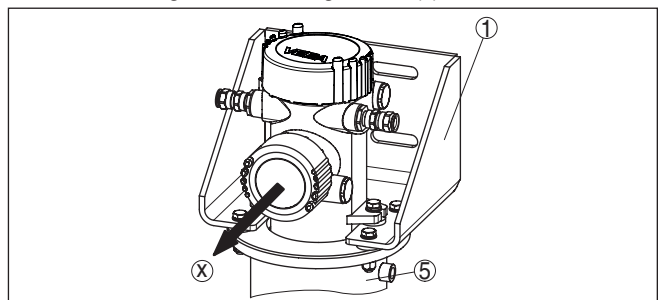

Fig. 3: Mounting direction of the sensor towards the fastening bracket

- 1 Fastening bracket
- 5 Housing cooling
- x Mounting direction of the housing

2. It is advisable to place the sensor and the housing cooling on the floor while inserting. Protect the sensor by covering the sensor housing during mounting.

Mount the sensor with the two screws (7) in the appropriate position.

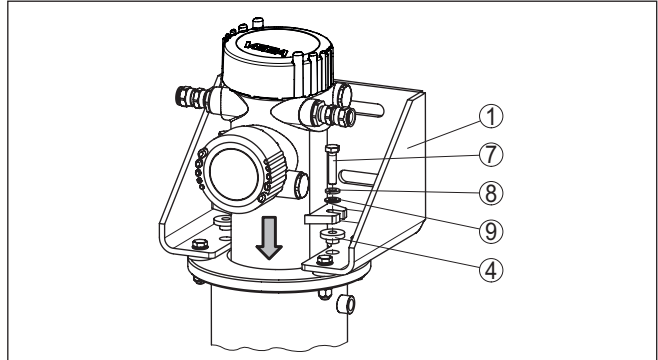

Fig. 4: Mounting the sensor

- 1 Fastening bracket
- 4 Isolating sleeve (2 pieces)
- 7 Hexagon screw M8 (2 pieces)
- 8 Retaining washer for M8 (2 pieces)
- 9 Washer for M8 (4 pieces)

Housing cooling

Take note of the following general mounting instructions:

- First of all, mount the fastening bracket and the housing cooling, and then the sensor
- The small lid of the instrument housing must point to the front after mounting the fastening bracket (x)
- The sensor together with the air cooling system is very heavy. Use a suitable lifting device for mounting

Mounting the scintillator cooling

Mount the scintillator cooling according to the following assembly drawing:

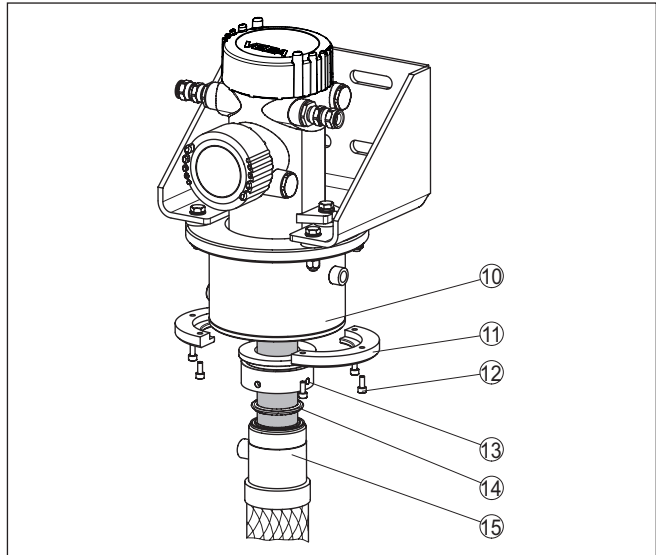

Fig. 5: Mounting scintillator cooling - upper part

- 10 Housing cooling
- 11 Holding flange (bisectional)
- 12 Hexagon screw (6 pieces)
- 13 Compression nut - top
- 14 Seal ring
- 15 Scintillator cooling hose (with connection thread)

1. Slide the upper compression nut (13) from below onto the black scintillator of the sensor. Make sure that the upper compression nut (13) has a fastening slot and that this slot points in the direction of the housing cooling (10).
2. Slide the seal ring (14) from below onto the scintillator cooling hose of the sensor. The seal ring (14) encircles the scintillator cooling hose very tightly and must be moved with a rolling motion over the entire length of the scintillator cooling hose. Make sure that the seal ring is not damaged or contaminated.
3. Push the upper compression nut (13) from below against the housing cooling (10).
4. Place the two half shells of the holding flange (11) from the side onto the upper compression nut (13) and fasten to the housing cooling (10) with the enclosed hexagon socket screws (12).
The compression nut remains rotatable.
5. Grease the upper thread of the scintillator cooling hose (15) with acid-free grease, e.g. Fuchs Lubritech Gleitmo 155 (heat-resistant hot thread compound). This makes screwing the parts together easier.
6. Push the scintillator cooling hose (15) from below onto the scintillator of the sensor.

7. Slide the upper seal ring (14) from below into the opening of the upper compression nut (13). Make sure that the seal ring (14) is clean and undamaged and not twisted during the process.
8. Slide the thread of the scintillator cooling hose (15) from below into the upper compression nut (13). Screw the scintillator cooling hose (15) slowly into the upper compression nut (13) up to the stop.

Turn the compression nut (13) with the attached hook wrench. The scintillator cooling hose is contracted on its thread in direction of the housing cooling. Turn the upper compression nut (13) with the enclosed hook wrench up to the stop.

9. The upper part of the scintillator cooling is then sealed. Mount the lower part as follows:

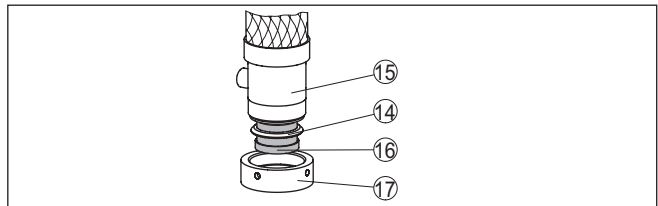

Fig. 6: Mounting scintillator cooling - lower part

- 14 Seal ring
- 15 Scintillator cooling hose (with connection thread)
- 16 Sensor (scintillator hose)
- 17 Compression nut - bottom



Tip:

The length of the scintillator cooling hose is measured exactly. Nevertheless you may have the impression that the scintillator cooling hose is too long.

Align the scintillator cooling hose in a straight line and make sure that the cooling hose is not bent. If necessary, the cooling hose can be pressed slightly in the length.

Make sure that the black scintillator of the sensor protrudes slightly out of the scintillator cooling hose.

10. Grease the lower thread of the scintillator cooling hose (15) with acid-free grease. This makes screwing the parts together easier.
11. Slide a seal ring (14) from below onto the scintillator hose (16) of the sensor. Make sure that the seal ring (14) is not damaged or contaminated.
12. Slide the lower compression nut (17) from below onto the thread of the scintillator cooling hose (15).
13. Screw the lower compression nut (17) slowly onto the scintillator cooling hose (15) up to the stop. Apply counterforce on the fixed tube part of the scintillator cooling hose (15) with a strap wrench (oil filter wrench) and tighten the lower compression nut (17) with the enclosed hook wrench up to the stop.

The scintillator cooling is now completely sealed.

Lifting the air cooling system



Information:

The sensor together with the air cooling system is very heavy. Use a suitable lifting device for mounting.

Use a hoisting sling with sufficient loading capacity. Take note of the sling marking. You can find the respective weight of the air cooling system in chapter " *Technical data*".

Place the lifting sling around the cooling tube directly below the flange. The loop is a so-called lark's foot.

Fasten the hoisting sling according to the following illustration.

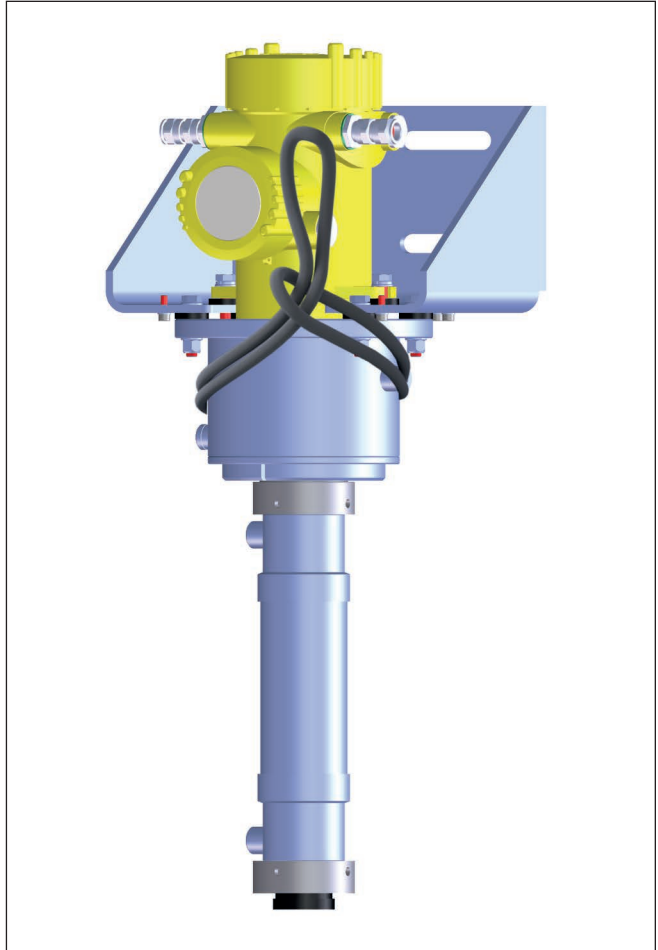

Fig. 7: Attaching the sling

Mounting the sensor

As soon as the air cooling system is mounted, you can install the sensor with the air cooling system in your facility.

You can mount the sensor on your vessel with the enclosed mounting clamps. A number of mounting clamps come with the air cooling system depending on the length of the sensor.

Use a mounting clamp approx. every 450 mm (17.72 in). Adjust the distances between the attached mounting clips.

Take note of the minimum bending radius of the housing cooling, which is 294 mm (11.57 in).

1. Determine the exact mounting position of one or several mounting clamps and mark the holes.

You can find the drilling template in the technical data.

Align the mounting positions exactly and average the distances between the enclosed mounting clamps.

Drill appropriate holes (max. M12) for fastening the mounting clamps.



Note:

The mounting clamps do not come with fastening screws. Use fastening elements that are appropriate for the situation in your plant.

2. Position the base plate (35) and fasten it in the specified mounting position.
3. Fasten additional mounting clamps exactly aligned in the same way.

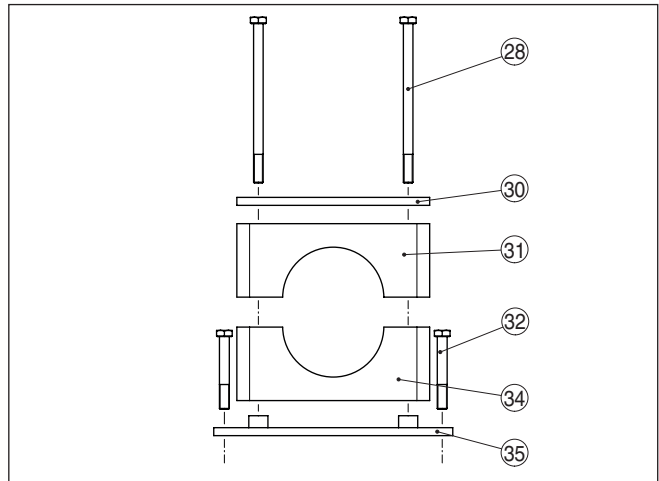

Fig. 8: Mounting clamps

- 28 Hexagon screw M6 x 100
- 30 Cover plate - metal
- 31 Upper clamping jaw
- 32 Fastening screws (provided by the customer)
- 34 Lower clamping jaw
- 35 Bottom plate - Metal

4. Place the lower clamping jaw (34) onto the bottom plate (35).

5. Insert the sensor with the cooling system into the lower clamping jaw (34) and align the cooling system.
6. Place the cover plate (30) onto the upper clamping jaw (31) and place the two parts onto the lower clamping jaw (34).
7. Insert the two hexagon screws (28) into the holes of the cover plate (30) and the upper clamping jaw (31) and then push the hexagon screws (28) through the two clamping jaws.
8. Tighten the two hexagon screws (28) with a torque of 8 Nm (5.9 lbf ft).

You can find further information on sensor mounting in the operating instructions manual of the sensor.

Mounting the housing cooling box

1. Open the fasteners (36) and remove the lid (37) from the lower part of the housing cooling box (38).
2. To make mounting easier, screw the cable glands of the sensor out of the instrument housing.
3. Place the lower part of the housing cooling box (38) on the fastening bracket (1).
4. Insert the 6 hexagon socket screws (39) from below through the mounting bracket (1) and tighten the screws with a torque of 4.5 Nm (3.3 lbf ft).

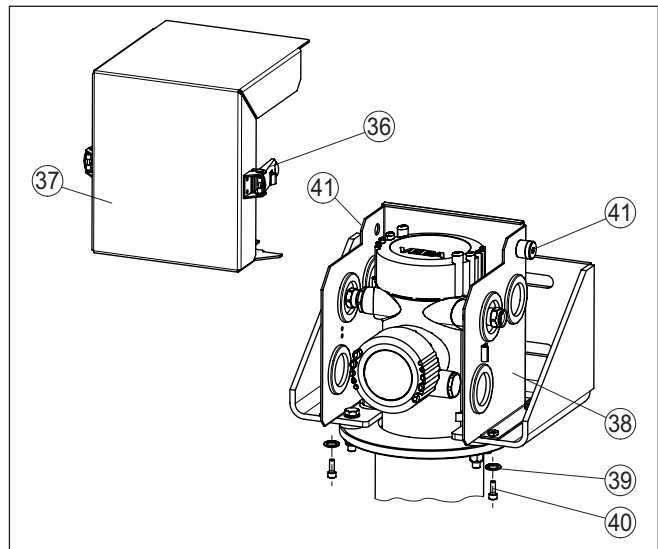

Fig. 9: Mounting the housing cooling box

36 Fasteners with safety latch

37 Lid of the housing cooling box

38 Lower part of the housing cooling box

39 Spring ring for M5 (6 pieces)

40 Hexagon socket screw M5 x 14 (6 pieces)

41 Connection opening for vortex cooler (type FOS 208SS 25 HVE BSP)

Electrical connection

1. Open the fasteners (36) and remove the lid from the housing cooling box (37).
2. Determine which cable gland you need for connection of the sensor.
3. Pierce a small hole with a sharp tool (e.g. pricking awl, scriber, etc.) in the center through the respective rubber diaphragms (42).
Do not use a knife or similar for puncturing

If you have accidentally pierced the wrong diaphragm, you can simply exchange the rubber diaphragms. If you have pierced a diaphragm too much, you can seal it with self-adhesive fabric tape.

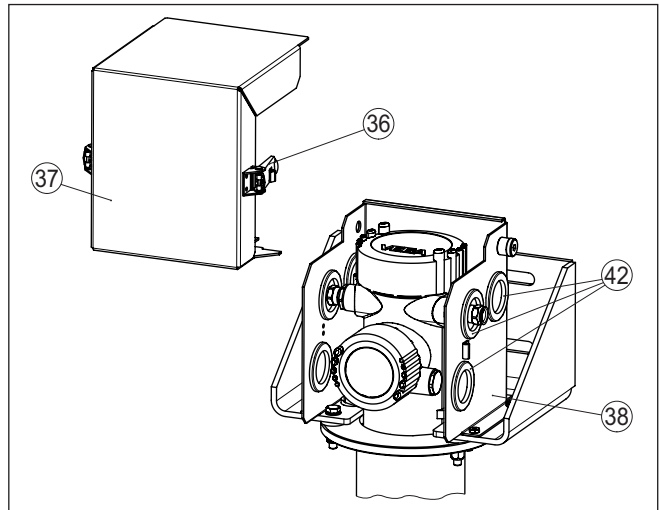

Fig. 10: Preparations for electrical connection

- 36 Fasteners with safety latch
- 37 Lid of the housing cooling box
- 38 Lower part of the housing cooling box
- 42 Rubber diaphragm

4. Insert the cable gland into the resulting opening and screw it tightly to the sensor housing.
Make sure that the rubber diaphragm encircles the cable gland completely so that not too much cooling air can escape.
5. Connect the sensor to voltage supply. Keep in mind the information in the operating instructions of the corresponding sensor or in the wiring diagram on the housing lid.



Note:

The cooling system is used in areas with high temperatures. Therefore, use temperature-resistant cable and install it in such a way that contact with hot components is avoided.

6. From the front side, place the lid of the housing cooling box (37) onto the lower part of the housing cooling box (38).

7. Close the two lateral fasteners (36).

Make sure that the fasteners (36) are provided with safety latches against unintentional opening. To open a fastener, you have to press the safety latch.

Connect cooling

The scintillator cooling and the housing cooling box must be connected to the cooling system.

All threads for the cooling connection on the sensor are inner threads.

Cooling systems (vortex cooler)

So-called Vortex coolers are proven possibilities for cooling the sensor.

You can connect the cooling air output of the vortex cooler directly to the housing cooling box or scintillator cooling.

The two vortex coolers are part of the scope of delivery. The coolers thus fit perfectly to your air cooling system with respect to size, cooling capacity and throughput.

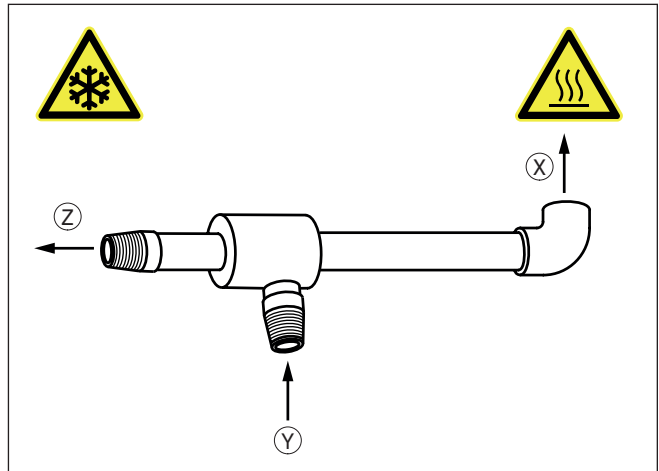

Fig. 11: Eddy current cooler (Vortex cooler)

- x Hot exhaust air
- y Supply air
- z Cooling air

**Caution:**

The vortex cooler gets very hot during operation. Hot air at approx. 100 °C (212 °F) escapes from the exhaust opening. Furthermore, the cooler or sensor can be very cold on the cold air side. Wear suitable protective clothing and prevent people from touching the cooling system by installing barriers, etc.

Make sure that the exhaust airstream can escape safely into the open. Make sure that no heat-sensitive components or cables are in the exhaust airstream.

If you want to direct the exhaust airstream in another direction, you have to use standard, angled metal fittings with ¼" screw connection.

1. The housing cooling box has two connection openings with ¼" connection.

Close the free openings with a respective bling plug.

2. The two lateral opening on the housing cooling have no function. Close the openings with the attached blind plugs to avoid penetration of dirt and moisture.

3. Connect the vortex coolers.

All threads for the cooling connection on the sensor are inner threads.

The vortex cooler type FOS 208SS 25 HVE BSP powers the housing cooling box. The vortex cooler type FOS 208SS 35 HVE BSP is connected to the scintillator cooling.

Screw in the short cooling air output of the vortex cooler and tighten it with a torque of 25 Nm (18.43 lbf ft).

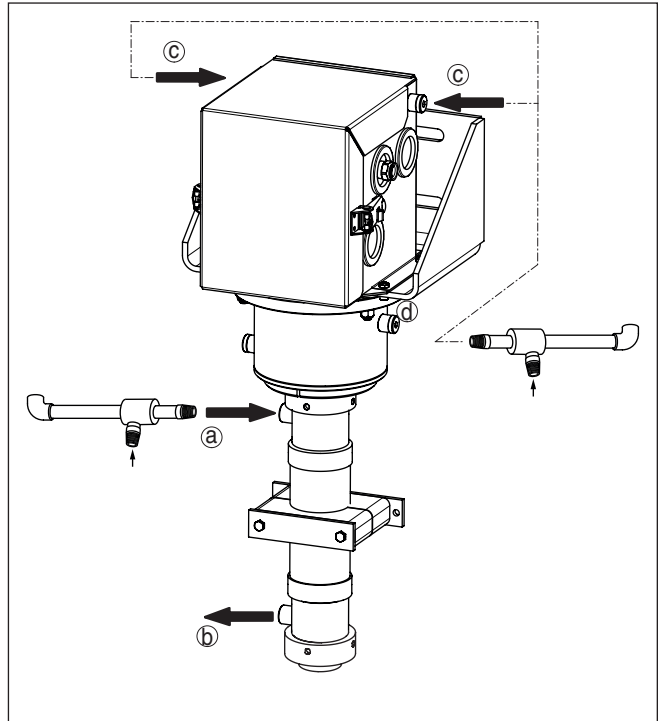

Fig. 12: Connection of the cooling air systems (vortex coolers)

- a Cooling air inlet - scintillator cooling
(vortex cooler type FOS 208SS 35 HVE BSP)
- b Cooling air outlet - scintillator cooling
- c Cooling air inlet - Housing cooling box
(vortex cooler type FOS 208SS 25 HVE BSP)
Connection on the left or right possible

For cooling, use clean, water-free compressed air of class 3:3:2 acc. to ISO 8573-1:2010. Make sure that your compressor has enough supply capacity. You can find information on quality, pressure, throughput and temperature of the cooling air in chapter " *Technical data*".

Make sure that the cooling air inlets do not freeze, e.g. in case of a shutdown.



Caution:

Do not loosen any screws or connections during operation and make sure that the cooling air supply is reliable and interruption-free. Plan the necessary steps for a possible compressed air failure.

We recommend installing a temperature sensor (in the housing cooling box) that triggers an alarm when a critical temperature is reached.



If you want to use the air cooling in an SIL-qualified application, you have to assess the SIL failure rates of the complete air cooling system and the cooling air supply yourself.

Install a protective grid

Take note of the operating instructions manuals of the corresponding radiometric sensors and the source holder.

When handling radioactive substances, unnecessary radiation exposure must be avoided.

If there are gaps or intervening spaces after mounting, provide protective fences or grids to keep hands away from the dangerous area. Such areas must be marked accordingly.

Install a safety barrier on both sides of the cooling system. A sheet metal cover or an appropriately shaped plastic sheet can also be used.

3 Replacement parts

3.1 Available spare parts - air cooling

Selected components of the cooling are available as replacement parts. The following parts are available:

The stated quantity is the quantity delivered.

Air cooling - vortex coolers

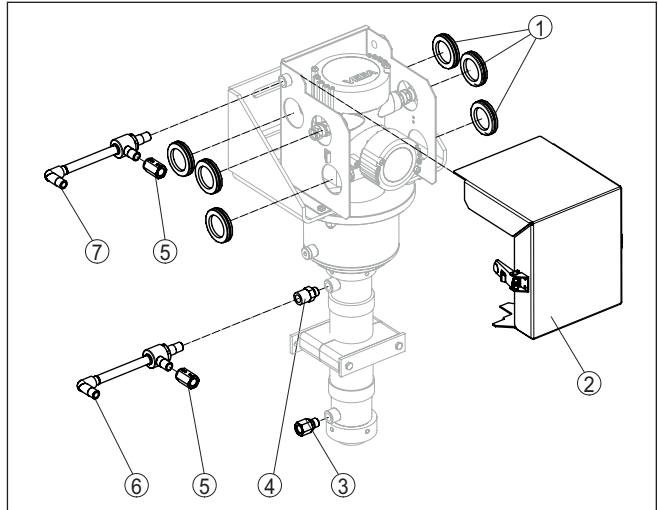

Fig. 13: Spare parts - air cooling with vortex cooler

- 1 Rubber diaphragm (2 pcs.)
- 2 Lid of the housing cooling box
- 3 Threaded adapter ¼ NPT (1 pce.)
- 4 Distance threaded adapter for vortex cooler ¼ NPT (1 pce.)
- 5 Threaded adapter for vortex cooler ¼ NPT (1 pce.)
- 6 Vortex cooler type FOS 208SS 35 HVE BSP (input for cooling air - scintillator cooling)
- 7 Vortex cooler type FOS 208SS 25 HVE BSP (input for cooling air - housing cooling box)

4 Supplement

4.1 Technical data

General data

Take note of the information in the operating instructions manual of the installed FIBERTRAC 31 level sensor and the source holder

Material 316L corresponds to 1.4404 or 1.4435

Materials

- Housing cooling	316L
- Housing cooling box	316L
- Metal fabric hose of the scintillator cooling	Stainless steel
- Seal	NBR

Application temperature See in the following " *Throughput - Coolant air*"

Weight

- Housing cooling	2.3 kg (5.1 lbs)
- Scintillator cooling	8.8 kg/m (1.62 oz/in)
- Housing cooling box	3.2 kg (7.1 lbs)
- Fastening bracket	4.8 kg (10.6 lbs)
- Fastening clamp	0.48 kg (1.06 lbs)

Total length of the air cooling system max. 7 m (275.6 in)

Torques

- Screws, Sensor mounting (M8)	15 Nm (11.06 lbf ft)
- Nuts, housing cooling (M8)	15 Nm (11.06 lbf ft)
- Hexagon socket screws, holding flange (M6)	4.5 Nm (3.3 lbf ft)
- Threaded fittings, vortex coolers	25 Nm (18.43 lbf ft)
- Screws for mounting clamps	8 Nm (5.9 lbf ft)

Connection thread of the cooling air inputs ¼" DIN ISO 228 outer thread
(adapters for NPT fittings are enclosed with respective version)

Throughput - Coolant air

Quality of the compressed air	ISO 8573-1:2010 [3:3:2]
Supply capacity - Compressor ¹⁾	
- Type FOS 208SS 25 HVE BSP	708 L/min (25 SCFM)
- Type FOS 208SS 35 HVE BSP	991 L/min (35 SCFM)
Air pressure of the supply air	5 ... 7.9 bar (72 ... 114 psig)
Temperature of the supply air	< +20 ... 25 °C (+68 ... 77 °F)
Ambient temperature	
- Sensor length 0.3 ... 5 m (1 ... 16.4 ft)	+80 °C (+176 °F)

¹⁾ at 6.9 bar (100 psig)

-
- Sensor length 5 ... 7 m (16.4 ... 23 ft) +70 °C (+158 °F)

Approvals

If you use an air cooling system in hazardous areas, make sure that the max. permissible temperatures in the Ex safety instructions are maintained around the sensor. If this is ensured, the sensor can also be used with an air cooling system in hazardous areas.

4.2 Dimensions

Active air cooling system

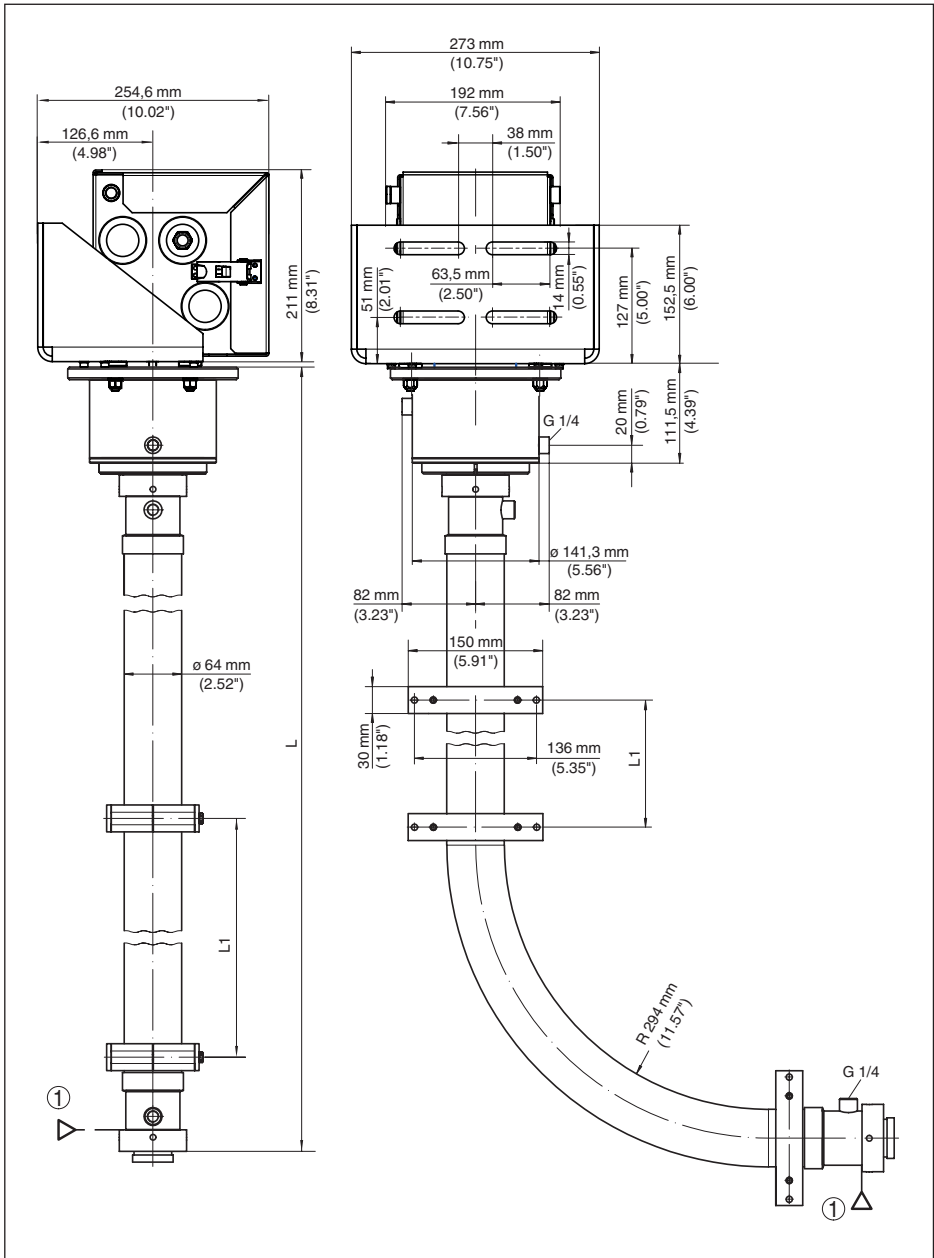

50339-EN-201 120

Fig. 14: Active air cooling system with scintillator cooling and housing cooling box

- 1 Position of the lower measuring range end (on the upper edge of the lower compression nut)*
- L Total length of the air cooling system*
- L1 Distance between the mounting clips = approx. 450 mm (17.72 in)*



Printing date:

VEGA

All statements concerning scope of delivery, application, practical use and operating conditions of the sensors and processing systems correspond to the information available at the time of printing.

Subject to change without prior notice

© VEGA Grieshaber KG, Schiltach/Germany 2020



50339-EN-201120

VEGA Grieshaber KG
Am Hohenstein 113
77761 Schiltach
Germany

Phone +49 7836 50-0
Fax +49 7836 50-201
E-mail: info.de@vega.com
www.vega.com