



Safety instructions

VEGABAR B8*(*).CE/Z/Q/J

VEGABAR B8*(*).VE

CSA 70015745

XP Class I, Div 1, Groups C and D

Ex d ia IIC T6 ... T1 Gb

CL I Zone 0/1, 1 AEx d ia IIC T6 ... T1 Gb

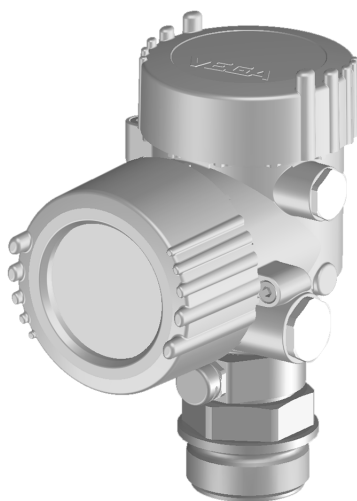

Document ID: 50600



VEGA

Contents

1	Area of applicability	3
2	General information	3
3	Technical data	4
3.1	VEGABAR B8* with integrated electronics Z (4 ... 20 mA), H (4 ... 20 mA/HART), A (4 ... 20 mA/HART with SIL qualification).....	4
3.2	VEGABAR B8* with integrated electronics P (Profibus PA), F (Foundation Fieldbus).....	4
3.3	VEGABAR B8* with integrated electronics S or T, for differential pressure measurement ..	5
3.4	VEGABAR B8* version with separate cable outlet.....	5
4	Application conditions	6
5	Protection against static electricity	8
6	Use of an overvoltage arrester	8
7	Grounding	8
8	Impact and friction sparks	9
9	Material resistance	9
10	Installation/mounting	9
11	Ignition protection type explosion proof enclosure XP, Ex "d"	9
12	Installation of the VEGABAR B8*(*).CE/Z/Q/J, VEGABAR B8*(*).VE with separate housing	11
13	Type and size of the threads for the "Ex-d" cable entries	11
14	Removing and replacing the red thread/dust cover	11
15	Installation Diagram	12

Supplementary documentation:

- Operating Instructions VEGABAR 81, 82, 83, 86, 87
- Certificate of Conformity CSA 70015745 (Document ID: 50601)

Editing status: 2019-09-06

1 Area of applicability

These safety instructions apply to the pressure transmitters VEGABAR B81/82/83/86/87.CE/Z/Q/J and VEGABAR B81/82/83/86/87.VE with integrated electronics Z (4 ... 20 mA), H (4 ... 20 mA/HART), A (4 ... 20 mA/HART with SIL qualification), P (Profibus PA), F (Foundation Fieldbus), S, T (differential pressure measurement) according to Certificate of Conformity CSA 70015745 (certificate number on the type label) and for all instruments with the number of the safety instruction (50600) on the type label.

2 General information

The pressure-based measuring instruments VEGABAR B8*(*).CE/Z/Q/J, VEGABAR B8*(*).VE are used for pressure and level measurement in hazardous areas.

The measured products can be combustible liquids, gases, mist or vapour.

The VEGABAR B8*(*).CE/Z/Q/J, VEGABAR B8*(*).VE consist of an "Ex-d" electronics housing with integrated electronics module, a process connection element and a sensor, the pressure measuring cell with optionally connected chemical seal. As an option, the display and adjustment module can also be mounted.

The VEGABAR B8*(*).CE/Z/Q/J, VEGABAR B8*(*).VE are suitable for use in hazardous atmospheres of all combustible materials of explosion groups C, D for applications requiring Class I, Div 1 instruments or for explosion groups IIA, IIB, IIC for applications requiring Class I, Zone 0/1, 1 AEx d ia IIC T6, Gb or Ex d ia IIC T6 ... T1 Gb instruments.

If the VEGABAR B8*(*).CE/Z/Q/J, VEGABAR B8*(*).VE are installed and operated in hazardous areas, the general Ex installation regulations in Canadian Electrical Code/US National Electrical Code, IEC 60079-14, as well as these safety instructions must be observed.

The operating instructions as well as the installation regulations and standards that apply for explosion protection of electrical systems must always be observed.

The installation of explosion-endangered systems must always be carried out by qualified personnel.

Installation at the separation between Zone 0 and Zone 1

The process connection element is installed in the separating wall, which separates areas in which EPL-Ga or EPL-Gb instruments are required. The electronics housing is installed in hazardous areas, requiring EPL-Gb instruments. The sensor is installed in hazardous areas requiring EPL-Ga instruments.

Installation in Zone 1

The VEGABAR B8*(*).CE/Z/Q/J, VEGABAR B8*(*).VE are installed in hazardous areas requiring EPL-Gb instruments.

Hazardous locations designation

CL I, Div 1, Group C, D

Ex d ia IIC T6 ... T1 Gb

CL I Zone 0/1, 1 AEx d ia IIC T6 ... T1 Gb

3 Technical data

3.1 VEGABAR B8* with integrated electronics Z (4 ... 20 mA), H (4 ... 20 mA/HART), A (4 ... 20 mA/HART with SIL qualification)

VEGABAR B8*(*) .CE/Z/Q/J, VEGABAR B8*(*) .VE with integrated electronics Z (4 ... 20 mA), H (4 ... 20 mA/HART), A (4 ... 20 mA/HART with SIL qualification), version with single chamber housing A, V,

Power supply and signal circuit: (terminals 1[+], 2[-] in the electronics compartment)

- $U_i = 9.6 \dots 35 \text{ V DC}$
- $U_m = 253 \text{ V AC}$

Indicating and adjustment circuit: (terminals 5, 6, 7, 8)

For connection to the circuit of the corresponding external display unit VEGADIS 81 in type of protection flame proof enclosure "XP/Ex-d" or for connection of a VEGABAR B80 in type of protection flame proof enclosure "XP/Ex-d" with integrated electronics S or T as differential pressure measurement.

Circuit for the display and adjustment module: (spring contacts in the .electronics compartment)

For connection to the display and adjustment module PLICSCOM.

VEGABAR B8*(*) .CE/Z/Q/J, VEGABAR B8*(*) .VE with integrated electronics Z (4 ... 20 mA), H (4 ... 20 mA/HART), A (4 ... 20 mA/HART with SIL qualification), version with double chamber housing D, W

Power supply and signal circuit: (terminals 1[+], 2[-] in the connection compartment)

- $U_i = 9.6 \dots 35 \text{ V DC}$
- $U_m = 253 \text{ V AC}$

Indicating and adjustment circuit: (terminals 5, 6, 7, 8)

For connection to the circuit of the corresponding external display unit VEGADIS 81 in type of protection flame proof enclosure "XP/Ex-d" or for connection of a VEGABAR B80 in type of protection flame proof enclosure "XP/Ex-d" with integrated electronics S or T as differential pressure measurement.

Circuit for the display and adjustment module: (spring contacts in the .electronics compartment)

For connection to the display and adjustment module PLICSCOM.

3.2 VEGABAR B8* with integrated electronics P (Profibus PA), F (Foundation Fieldbus)

VEGABAR B8*(*) .CE/Z/Q/J, VEGABAR B8*(*) .VE with integrated electronics P (Profibus PA), F (Foundation Fieldbus), version with single chamber housing A, V

Power supply and signal circuit: (terminals 1[+], 2[-] in the electronics compartment)

- $U_i = 9 \dots 32 \text{ V DC}$
- $U_m = 253 \text{ V AC}$

<p>Indicating and adjustment circuit: (terminals 5, 6, 7, 8)</p>	<p>For connection to the circuit of the corresponding external display unit VEGADIS 81 in type of protection flame proof enclosure "XP/Ex-d" or for connection of a VEGABAR B80 in type of protection flame proof enclosure "XP/Ex-d" with integrated electronics S or T as differential pressure measurement.</p>
<p>Circuit for the display and adjustment module: (spring contacts in the .electronics compartment)</p>	<p>For connection to the display and adjustment module PLICSCOM.</p>

VEGABAR B8*(*).CE/Z/Q/J, VEGABAR B8*(*).VE with integrated electronics P (Profibus PA), F (Foundation Fieldbus), version with double chamber housing D, W

<p>Power supply and signal circuit: (terminals 1[+], 2[-] in the connection compartment)</p>	<ul style="list-style-type: none"> ● $U_i = 9 \dots 32 \text{ V DC}$ ● $U_m = 253 \text{ V AC}$
<p>Indicating and adjustment circuit: (terminals 5, 6, 7, 8)</p>	<p>For connection to the circuit of the corresponding external display unit VEGADIS 81 in type of protection flame proof enclosure "XP/Ex-d" or for connection of a VEGABAR B80 in type of protection flame proof enclosure "XP/Ex-d" with integrated electronics S or T as differential pressure measurement.</p>
<p>Circuit for the display and adjustment module: (spring contacts in the .electronics compartment)</p>	<p>For connection to the display and adjustment module PLICSCOM.</p>

3.3 VEGABAR B8* with integrated electronics S or T, for differential pressure measurement

VEGABAR B8*(*).CE/Z/Q/J, VEGABAR B8*(*).VE with integrated electronics S or T, for differential pressure measurement

<p>Power supply and signal circuit: (terminals 5, 6, 7, 8 in the electronics compartment)</p>	<p>For connection to a VEGABAR B8*.*E***** with integrated electronics H, A, P, F for differential pressure measurement</p>
---	---

3.4 VEGABAR B8* version with separate cable outlet

VEGABAR B8*(*).CE/Z/Q/J, VEGABAR B8*(*).VE Version with separate cable outlet (all electronics)

<p>Circuit between sensor unit and external electronics (terminal 1 - yellow, terminal 2 - white, terminal 3 - red, terminal 4 - black)</p>	<p>In ignition protection type intrinsic safety Ex ia IIC With VEGABAR B8*.*E in the version with fix mounted cable on the sensor unit and external electronics, the supplied cable between the external housing and the sensor unit must not exceed a length of 180 m.</p>
---	---

The metallic parts of VEGABAR B8*(*).CE/Z/Q/J, VEGABAR B8*(*).VE are electrically connected with the earth terminals.

The intrinsically safe circuits to the sensor are galvanically connected to ground potential.

4 Application conditions

VEGABAR B8*(*)..CE/Z/Q/J, VEGABAR B8*(*)..VE with integrated electronics Z (4 ... 20 mA), H (4 ... 20 mA/HART) or A (4 ... 20 mA/HART with SIL qualification), P (Profibus PA), F (Foundation Fieldbus) or S, T (differential pressure measurement)

The max. permissible ambient temperatures depending on the temperature classes are specified in the following tables.

Installation at the separation between Zone 0 and Zone 1, Division 1 installations

Temperature class	Ambient temperature on the electronics (Zone 1)	Product temperature range (sensor, zone 0)
T6	-50 ... +60 °C	-20 ... +23 °C
T5, T4, T3, T2, T1	-50 ... +60 °C	-20 ... +60 °C

The process pressure of the media must be between 0.8 ... 1.1 bar. The 80% consideration is taken into account with the permissible ambient temperatures. If the VEGABAR B8*(*)..CE/Z/Q/J, VEGABAR B8*(*)..VE are operated at temperatures higher than those specified in the above table, please make sure by means of appropriate measures that there is no danger of ignition from the hot surfaces. The maximum temperature on the electronics/housing should not exceed the values stated in the above table. The application conditions in areas without hazardous mixtures are specified in the manufacturer information.

Div 1, Zone 1 installation, VEGABAR 82, VEGABAR 83 with METEC measuring cell

Temperature class	Ambient temperature on the electronics (Zone 1)	Product temperature range (sensor, zone 1)
T6	-50 ... +60 °C	-50 ... +39 °C
T5	-50 ... +60 °C	-50 ... +100 °C
T4	-50 ... +50 °C	-50 ... +135 °C
T3, T2, T1	-50 ... +50 °C	-50 ... +200 °C

Div 1, Zone 1 installation, VEGABAR 83 version with piezoresistive/strain gauge measuring cell, version without cooling element

Temperature class	Ambient temperature on the electronics (Zone 1)	Product temperature range (sensor, zone 1)
T6	-50 ... +60 °C	-50 ... +39 °C
T5	-50 ... +60 °C	-50 ... +85 °C
T4	-50 ... +40 °C	-50 ... +105 °C
T4, T3, T2, T1	-50 ... +30 °C	-50 ... +120 °C

Div 1, Zone 1 installation, VEGABAR 81, VEGABAR 83 version with piezoresistive/strain gauge measuring cell, version with cooling element

Temperature class	Ambient temperature on the electronics (Zone 1)	Product temperature range (sensor, zone 1)
T6	-50 ... +60 °C	-50 ... +39 °C
T5	-50 ... +60 °C	-50 ... +85 °C

Temperature class	Ambient temperature on the electronics (Zone 1)	Product temperature range (sensor, zone 1)
T4	-50 ... +50 °C	-50 ... +120 °C
T3, T2, T1	-50 ... +40 °C	-50 ... +150 °C

If the VEGABAR B8*(*) .CE/Z/Q/J, VEGABAR B8*(*) .VE are operated at temperatures higher than those specified in the above table, please make sure through appropriate measures that there is no danger of ignition from the hot surfaces. The max. permissible temperature on the electronics/housing should not exceed the values specified in the above table. The application conditions during operation with no explosive mixtures present are stated in the manufacturer information.

Temperature derating

VEGABAR 82, version process temperature +130 °C

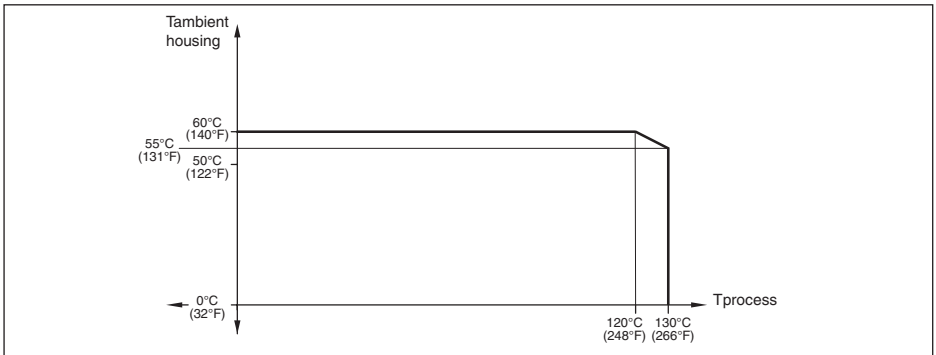

VEGABAR 82, version process temperature +150 °C

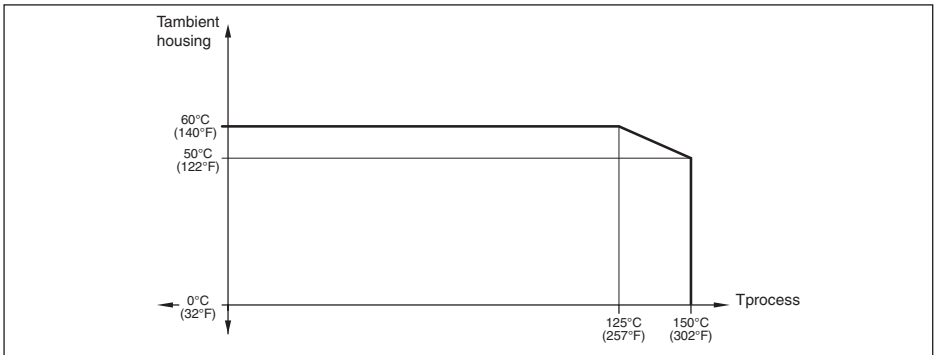

VEGABAR 81, VEGABAR 83

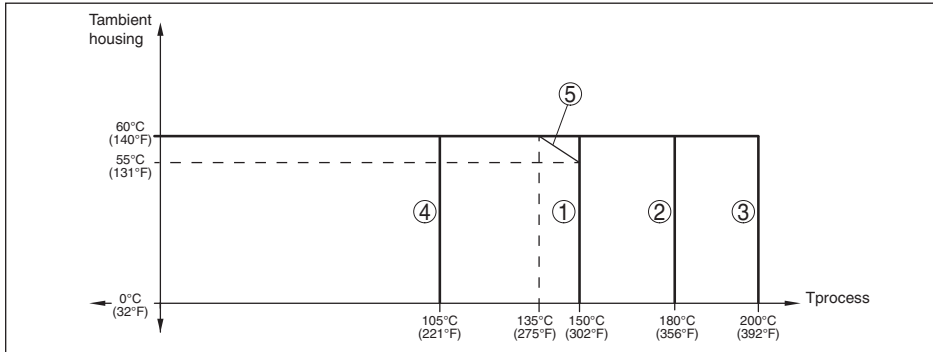

- 1 Version: METEC measuring cell, process temperature max. 150 °C
- 2 Version: METEC measuring cell, process temperature max. 180 °C
- 3 Version: METEC measuring cell, process temperature max. 200 °C
- 4 Version: Piezoresistive/strain gauge measuring cell, without cooling element
- 5 Version: Piezoresistive/strain gauge measuring cell, with cooling element

The temperature ranges for operation specified in the operating instruction must not be exceeded.

5 Protection against static electricity

The VEGABAR B8*(*) .CE/Z/Q/J, VEGABAR B8*(*) .VE in versions with electrostatically chargeable plastic parts, such as e.g. metal housing with inspection window, plastic-coated sensors, suspension cable/hose, distance tube or the connection cable of the separated version, have a caution label that points out the safety measures that must be taken with regard to electrostatic charges during operation.

WARNING -- POTENTIAL ELECTROSTATIC CHARGING
HAZARD -- SEE INSTRUCTIONS

AVERTISSEMENT -- DANGER POTENTIEL DE CHARGES
ÉLECTROSTATIQUES -- VOIR INSTRUCTIONS

Caution: Plastic parts! Danger of electrostatic charging!

- Avoid friction
- No dry cleaning
- Do not mount in areas with flowing, non-conductive products

6 Use of an overvoltage arrester

If necessary, a suitable overvoltage arrester can be connected in front of the VEGABAR B8*(*) .CE/Z/Q/J, VEGABAR B8*(*) .VE.

A suitable overvoltage arrester must be connected in front as protection against voltage surges according to IEC 60079-14 chapter 12.3.

7 Grounding

The "Ex-d" terminal compartment of VEGABAR B8*(*) .CE/Z/Q/J, VEGABAR B8*(*) .VE includes a safety barrier without galvanic separation. For safety reasons, the intrinsically safe circuits must be grounded.

The external/internal ground connection terminal on the housing of VEGABAR B8*(*).CE/Z/Q/J, VEGABAR B8*(*).VE must have a low impedance connection to the potential equalization.

8 Impact and friction sparks

VEGABAR B8*(*).CE/Z/Q/J, VEGABAR B8*(*).VE in light metal versions (e.g. aluminium/titanium) must be mounted in such a way that sparks from impact and friction between light metals and steel (except stainless steel, if the presence of rust particles can be excluded) cannot occur.

9 Material resistance

VEGABAR B8*(*).CE/Z/Q/J, VEGABAR B8*(*).VE should only be used in media against which the wetted materials are sufficiently resistant.

10 Installation/mounting

The VEGABAR B8*(*).CE/Z/Q/J, VEGABAR B8*(*).VE have to be mounted such that the sensor is effectively secured against touching the vessel wall, under consideration of other vessel installations and flow conditions in the vessel. This applies especially to suspension pressure transmitters and versions with distance tube lengths over 3 m.

11 Ignition protection type explosion proof enclosure XP, Ex "d"

The terminals for connecting to the operating voltage, i.e. signal circuits, are integrated in a compartment according to protection type explosion proof enclosure "XP/Ex-d".

The gaps between housing and cover as well as between threaded fitting and container are ignition-proof gaps.

The explosions proof connection compartment is provided with a M20 x 1.5 or 1/2-14 NPT thread for connection to a certified "Conduit" system or for mounting of a certified explosion proof cable entry (only for zones applications). Cable entries of simple construction may not be used. When connecting to a "Conduit" system, the associated sealing facility must be located directly on the explosions proof connection compartment.

The factory-installed screw plug or blind plug (depending on the type ordered) is part of the "Ex-d" housing. If a non factory-installed screw plug is used, it must be suitable for the function and certified.

Before opening the lid of a "XP/Ex-d" compartment or in case it is already open (e. g. during connection or service work), make sure that either the supply cable is completely voltage free or no explosive atmosphere is present.

When wiring the connection line to the explosion proof connection compartment, it must be sufficiently secured against damage.

The cover of the explosion proof housing must be screwed in completely before commissioning and secured by screwing out the lid locking screw all the way to the stop.

Unused openings must be sealed accordingly.

Single chamber housing with explosion proof connection compartment (XP, Ex d)



- 1 Thread protection
- 2 Locking screw of the cover
- 3 Screw plug
- 4 Marking of the thread
- 5 "Ex-d" connection compartment with electronics module
- 6 Optionally with inspection window
- 7 External ground terminal

Double chamber housing with two XP, Ex d compartments

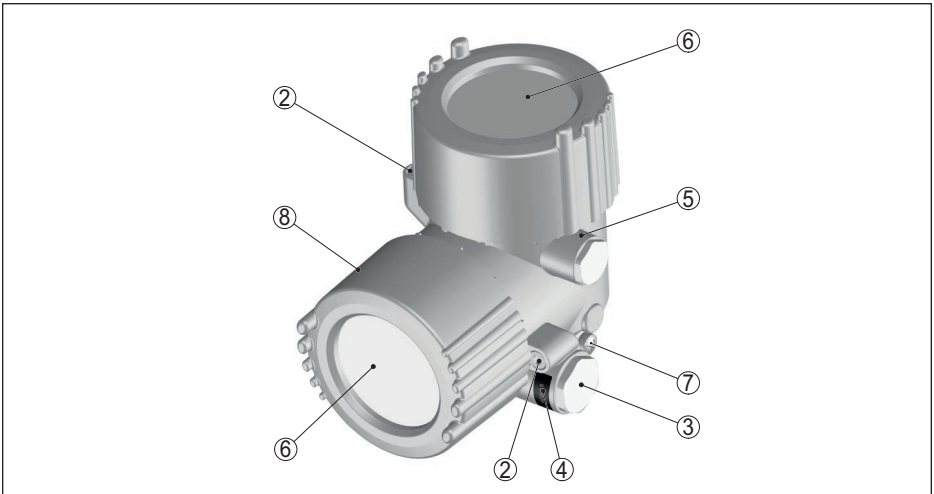

- 1 Thread protection
- 2 Locking screw of the cover
- 3 Screw plug
- 4 Marking of the thread
- 5 "Ex-d" electronics compartment
- 6 Optionally with inspection window
- 7 External ground terminal
- 8 "Ex-d" connection compartment

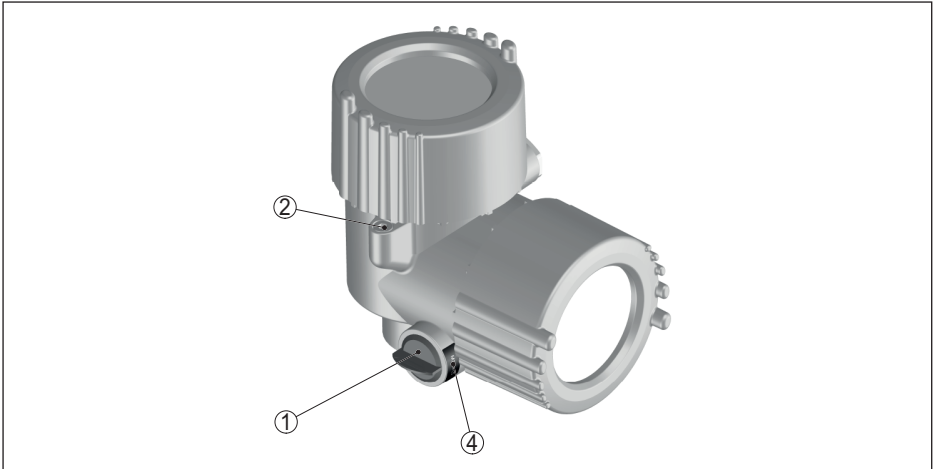

- 1 Thread protection
- 2 Locking screw of the cover
- 3 Marking of the thread
- 4 Marking of the thread

12 Installation of the VEGABAR B8*(*).CE/Z/Q/J, VEGABAR B8*(*).VE with separate housing

With the version with separate housing of the pressure transmitter VEGABAR B8*(*).CE/Z/Q/J, VEGABAR B8*(*).VE, the potential equalization must be provided in the complete range of the connection cable between electronics housing and transmitter housing.

13 Type and size of the threads for the "Ex-d" cable entries

The "Ex-d" connection compartment of VEGABAR B8*(*).CE/Z/Q/J, VEGABAR B8*(*).VE with cable entry type D, 1 has cable entries M20 x 1.5.

The "Ex-d" connection compartment of VEGABAR B8*(*).CE/Z/Q/J, VEGABAR B8*(*).VE with cable entry type N, Q has cable entries ½-14 NPT.

14 Removing and replacing the red thread/dust cover

The red thread or/dust covers screwed in when the instrument is shipped (depending on the version) must be removed before setup. The openings must be closed before setup by a way approved for "XP/Ex-d". Approved and suitable cable glands or blind plugs must be installed according to the supplied documents.

Before setting up VEGABAR B8*(*).CE/Z/Q/J, VEGABAR B8*(*).VE you have to check if all other openings are closed in a way approved for the ignition protection.

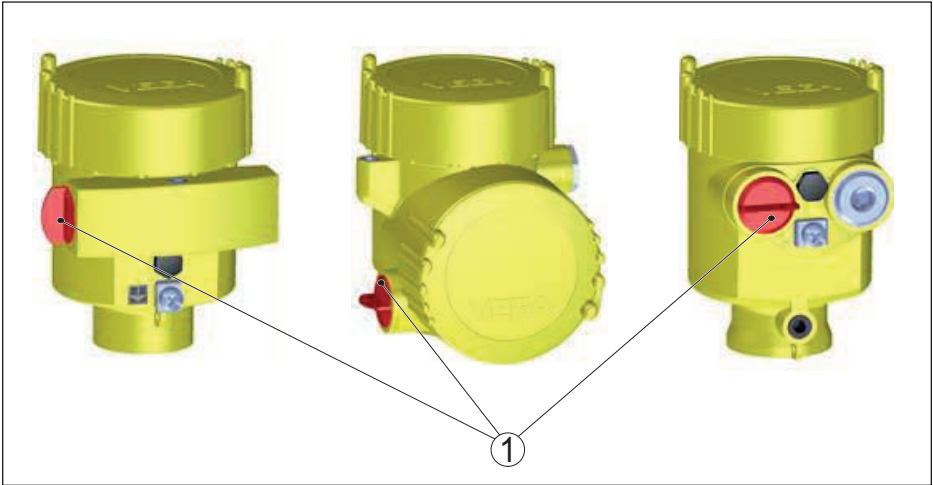

1 Red thread or dust cover must be removed before setup. The opening must be closed before setup by a way approved for the flame proofing.

15 Installation Diagram

Installation Control Diagram

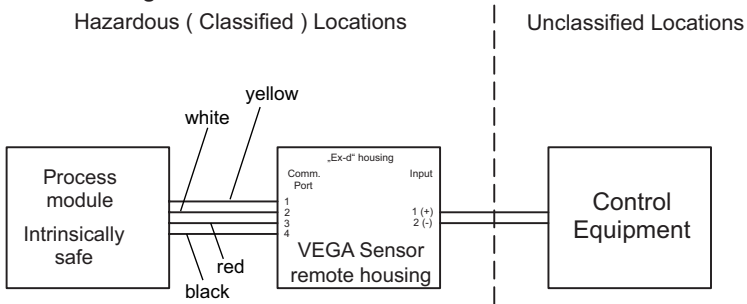

Fig. 1: VEGABAR B8*(*).CE/Q

General

For Division 1 installations, the Sensor shall be installed in accordance with the National Electrical Code® (ANSI/NFPA 70) or Canadian Electrical Code, CSA C22.1 Part 1 Appendix F for division 1 wiring methods.

Division 1 Installation requirements must be complied with if one or more of the following are located in a Division 1 hazardous location: Sensor, Probe or Field Device.

The Field Device manufacturer's installation drawing shall be followed when installing this equipment.

No revision to drawing without prior Approval by FM Approvals and CSA International.

WARNING: Substitution of components may impair suitability for hazardous locations.

WARNING: Do not open when an explosive atmosphere is present.

Barriers and instruments to carry same Agency Approval.

VEGA Sensor

For Division 2 Installations, the Sensor shall be installed in accordance with the National Electrical Code® (ANSI/NFPA 70) or Canadian Electrical Code, CSA C22.1 Part 1 Appendix F for division 2 wiring methods.

The VEGA Sensor is a VEGABAR B8*(*) .CE/Z/Q/J, VEGABAR B8*(*) .VE.

VEGABAR B8*(*) .CE/Q

Power supply and signal circuit: (terminals 1[+], 2[-])

Electronics 4 ... 20 mA/HART:

U = 9.6 ... 35 V DC

Electronics Profibus PA, Foundation Fieldbus:

U = 9 ... 32 V DC

Um = 253 V

Circuit for connection of an Indication or Display unit or for connection of a VEGABAR B8*(*) .CE with electronics S, T for pressure difference measurement: (terminals 5, 6, 7, 8)

In ignition protection type flameproof enclosure "d"

The metallic parts of VEGABAR B8*(*) .CE/Z/Q/J, VEGABAR B8*(*) .VE are electrically connected with the internal and external earth terminals.

VEGA Display

The VEGA Display is a VEGADIS 61 or VEGADIS 81.

The Field Device manufacturer's installation drawing shall be followed when installing this equipment.

For Division 1 Installations, the terminal marked sign "earth" shall be grounded per ANSI/NFPA 70 article 504.50 or CSA C22.1 Part 1 Appendix F F3.2.2 and the Field Device wiring shall be segregated from the supply wiring.

For Division 2 Installations, the Field Device shall be installed in accordance with the National Electrical Code® (ANSI/NFPA 70) or Canadian Electrical Code, CSA C22.1 Part 1 Appendix F for Division 2 wiring methods including Nonincendive Field Wiring when using the parameters shown.

VEGABAR Version with external housing

The cable between the external housing with implemented electronics and the process unit is an intrinsically safe circuit.

The regulations for the interconnection of intrinsically safe circuits between VEGABAR B8* housing and the process unit are complied with the lengths of the cable between external housing and the process unit does not exceed 180 meter.



A large grid of graph paper for taking notes, consisting of 20 columns and 30 rows of small squares.

50600-EN-190906

Printing date:

VEGA

All statements concerning scope of delivery, application, practical use and operating conditions of the sensors and processing systems correspond to the information available at the time of printing.

Subject to change without prior notice

© VEGA Grieshaber KG, Schiltach/Germany 2019

50600-EN-190906

VEGA Grieshaber KG
Am Hohenstein 113
77761 Schiltach
Germany

Phone +49 7836 50-0
Fax +49 7836 50-201
E-mail: info.de@vega.com
www.vega.com