

VEGAPULS 69

Modbus and Levelmaster protocol

Radar sensor for continuous level measurement of bulk solids

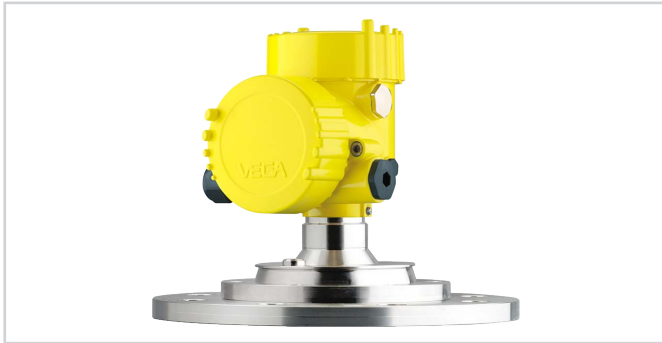

Application area

The VEGAPULS 69 is a sensor for continuous measurement of bulk solids under different process conditions. The sensor is ideal for level measurement in very high silos, large bunkers and segmented vessels. The very good signal focussing ensures a simple setup and a reliable measurement.

The VEGAPULS 69 can be equipped with an encapsulated plastic antenna or a lens antenna integrated in the metal flange. Due to this, an optimum adaptation to different applications is possible.

Your benefit

- Maintenance-free operation thanks to non-contact measuring principle
- High plant availability, because wear and maintenance free
- Reliable measurement independent of steam, dust and noise

Function

The sensor emits a continuous radar signal through the antenna. The emitted signal is reflected by the medium and received as an echo by the antenna.

The frequency difference between the emitted and received signal is proportional to the distance and depends on the filling height. The determined filling height is converted into a respective output signal and outputted as measured value.

Technical data

Measuring range up to	120 m (393.7 ft)
Deviation	±5 mm
Process fitting	Mounting strap, flanges from DN 80 or 3", thread from G1½ or 1½NPT
Process pressure	-1 ... 20 bar (-100 ... 2000 kPa/-14.5 ... 290.1 psig)
Process temperature	-40 ... +200 °C (-40 ... +392 °F)
Ambient, storage and transport temperature	-40 ... +80 °C (-40 ... +176 °F)
Operating voltage	8 ... 30 V DC

Materials

The wetted parts of the instrument are made of 316L, PP or PEEK. The process seal is made of FKM or EPDM.

You will find a complete overview of the available materials and seals in the "Configurator" at www.vega.com and "VEGA Tools".

Housing versions

The housings are available as double chamber version in plastic, stainless steel or Aluminium. They are available in protection class IP 66/ IP 67.

Electronics versions

The instruments are available in different electronics versions.

Apart from 4 ... 20 mA/HART in two and four-wire version, there are also digital versions with Profibus PA, Foundation Fieldbus and Modbus protocols. Another HART version is available with integrated accumulator.

Approvals

The instruments are suitable for use in hazardous areas and are approved, for example, according to ATEX.

You can find detailed information at www.vega.com/downloads and "Approvals".

Adjustment

Adjustment on the measurement loop

The adjustment of the instrument is carried out via the optional display and adjustment module PLICSCOM or via a PC with the adjustment software PACTware and corresponding DTM.

The connection of the PC is carried out via USB directly on the instrument or via an interface adapter USB/RS 485 on the signal cable.

Wireless adjustment via Bluetooth

The Bluetooth version of display and adjustment module enables a wireless connection to standard adjustment units. This can be smartphones/tablets with iOS or Android operating system or PCs with PACTware and Bluetooth USB adapter.



Wireless connection to standard operating devices

Adjustment is hence carried out via a free-of-charge app from the Apple App Store or the Google Play Store or via the adjustment software PACTware and respective DTM.

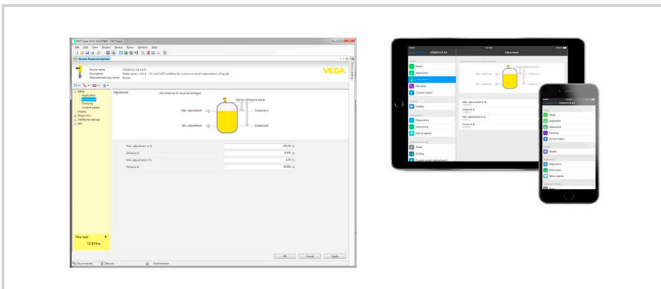

Adjustment via PACTware or app

Electrical connection

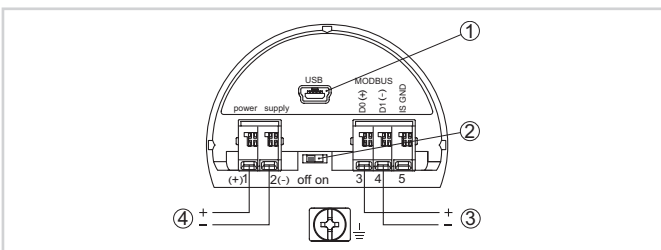

Terminal compartment

- 1 USB interface
- 2 Slide switch for integrated termination resistor (120 Ω)
- 3 Modbus signal
- 4 Voltage supply

You can find details on electrical connection in the instrument operating instructions at www.vega.com/downloads.

Dimensions

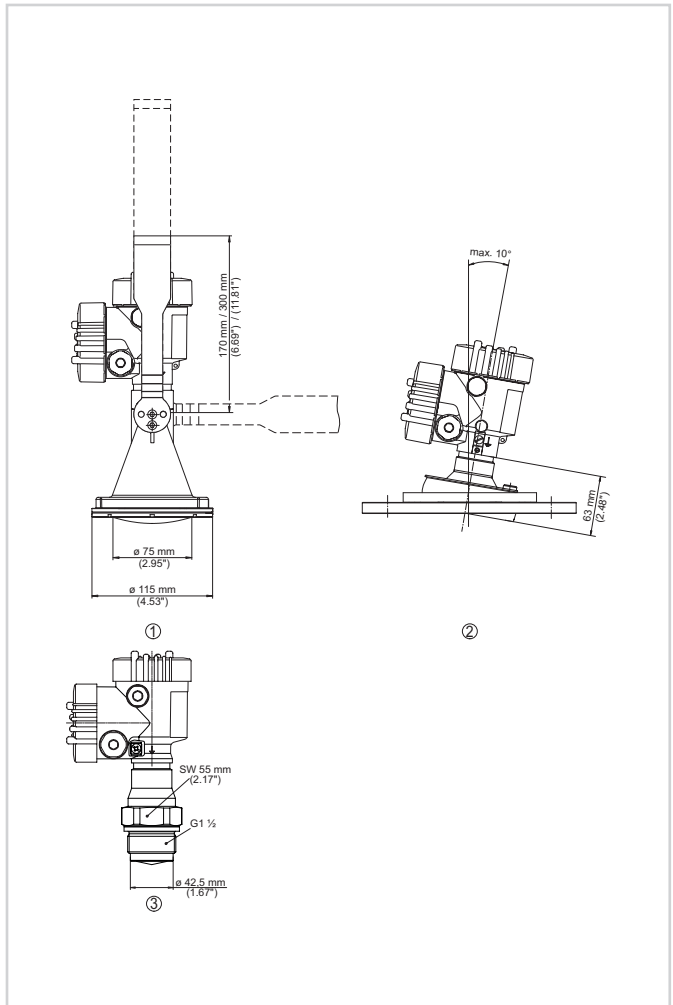

VEGAPULS 69, metal-jacketed lens antenna in flange version

- 1 Metal jacketed lens antenna with swivelling holder
- 2 Plastic horn antenna with mounting strap
- 3 Thread with integrated horn antenna

Information

You can find further information about the VEGA product line on www.vega.com.

In the download section at www.vega.com/downloads you'll find operating instructions, product information, brochures, approval documents, instrument drawings and much, much more.

There, you will also find GSD and EDD files for Profibus PA systems as well as DD and CFF files for Foundation Fieldbus systems.

Instrument selection

With the "Finder" at www.vega.com and "VEGA Tools" you can select the most suitable measuring principle for your application.

You can find detailed information on the instrument versions in the "Configurator" at www.vega.com and "VEGA Tools".

Contact

You can find the VEGA agency serving your area on our homepage www.vega.com.