

Supplementary instructions

Water cooling - FIBERTRAC 31

Active water cooling system for radiation-based sensors

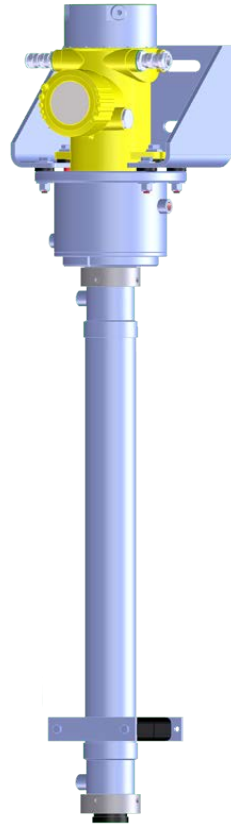

Document ID: 48524



VEGA

Contents

1	Product description	3
1.1	Configuration	3
2	Mounting	5
3	Replacement parts	17
3.1	Available spare parts - water cooling	17
4	Supplement	19
4.1	Technical data	19
4.2	Dimensions	21

1 Product description

1.1 Configuration

The active water cooling system is suitable for radiation-based sensors of series FIBERTRAC 31.

The water cooling system consists of several modules.

- Housing cooling lid (A)** The housing cooling lid can be screwed onto the instrument housing instead of the normal housing lid.
- Housing cooling (B)** The cooling module for the housing cools the lower part of the sensor housing.
- Scintillator cooling (C)** The flexible cooling module for the scintillator cools the active measuring part of the sensor.

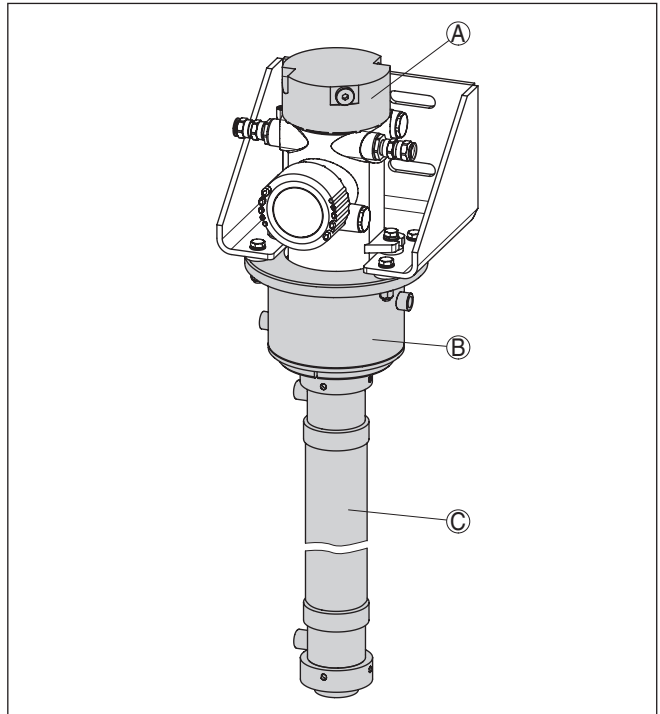

Fig. 1: Active water cooling system with fastening bracket

- A Housing cooling lid
- B Housing cooling
- C Scintillator cooling (flexible)

Scope of delivery

The following parts belong to the scope of delivery of the water cooling system:

- Scintillator cooling hose (1 piece)
- Flange, sectioned (2 pieces)
- Hexagon socket screw M5 x 12 (6 pieces)
- Sealing ring \varnothing 42 x 6 mm (2 pieces)
- Compression nut, top (1 piece)
- Compression nut, bottom (1 piece)
- Mounting clamp (quantity depending on sensor length)
- Fastening bracket
- Housing cooling lid
- Isolating sleeve (6 pieces)
- Fixing screw M8 x 35 (2 pieces)
- Fixing screw M8 x 40 (4 pieces)
- Washer for M8 (10 pieces)
- Spring ring for M8 (2 pieces)
- Hexagon nut M8 (4 pieces)
- Coolant hose $\frac{1}{4}$ ", length: 300 mm (11.81 in)
- Coolant hose $\frac{1}{4}$ ", length: 550 mm (21.65 in)
- NPT threaded adapter for cooling hoses $\frac{1}{4}$ " (optional)
- Hook wrench size 68 - 75, DIN 1810, Form B

i **Information:**

When the sensor is ordered with cooling, the sensor and the water cooling system are shipped already premounted.

If the cooling is ordered later, you have to mount the water cooling system on the sensor.

You can find further information in chapter "*Mounting*".

2 Mounting

Operating instructions

Mounting preparations

Take note of the operating instructions manuals of the corresponding radiation-based sensors and the source holder.



Warning:

During all mounting and dismantling work, the source container must be in switch position "OFF" and secured by a lock.

Carry out all work within the shortest possible time and at the largest possible distance. Provide suitable shielding.

Avoid risk to other persons by taking suitable measures (e.g. safety fence, etc.).

Mounting may only be carried out by authorized, qualified personnel who are monitored for radiation exposure according to local laws or the handling permit. Take note of the specifications in the handling permit. Also take the local conditions into account.



Caution:

The cooling system is used in areas with high temperatures. Therefore, use temperature-resistant cable and install it in such a way that contact with hot components is avoided.

General mounting instructions



Information:

When the sensor is ordered with cooling, the sensor and the water cooling system are shipped already premounted.

If the cooling is ordered later, you have to mount the water cooling system on the sensor.

Required tools:

- Hook wrench size 68 - 75, DIN 1810, Form B - for screwing on the cooling hose (comes with the water cooling system)
- Allen key size 4 - for the bisectional holding flange
- Fork wrench SW10 mm - for the mounting clip
- Fork wrench SW13 mm (2 pieces) - for the housing cooling
- Fork wrench SW19 mm (2 pieces) - for the hose fittings of the cooling circuit
- Acid-free grease - to screw in the compression nuts more easily

Take note of the following general mounting instructions:

- First of all, mount the fastening bracket and the housing cooling, and then the sensor.
- The small lid of the instrument housing must point to the front after mounting the fastening bracket (x)
- The sensor together with the water cooling system is very heavy. Use a suitable lifting device for mounting, e.g. a sling

Mounting

1. Place the isolating sleeves (4) between the housing cooling (5) and the fastening bracket (1).

Mount the fastening bracket

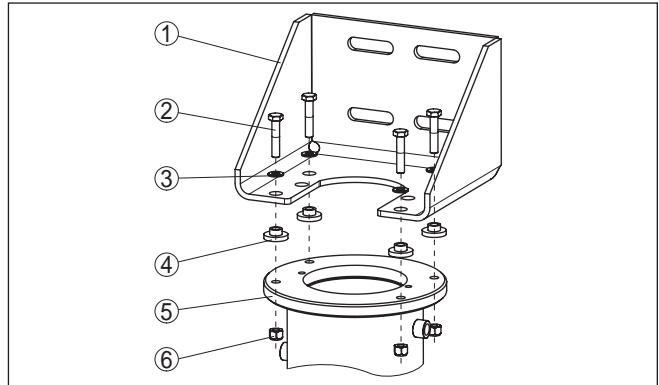

Fig. 2: Housing cooling

- 1 Fastening bracket
- 2 Hexagon screws M8 x 40 (4 pieces)
- 3 Washer for M8 (4 pieces)
- 4 Isolating sleeve (4 pieces)
- 5 Housing cooling
- 6 Hexagon nut M8 (4 pieces)

2. Place the fastening bracket (1) onto the housing cooling (5). Make sure that the coolant connections point in a suitable direction. Rotating the holding bracket later (1) is very difficult.
3. Connect the fastening bracket (1) with the housing cooling (5) according to the illustration and tighten the screws (2, 3, 6) with a torque of 15 Nm (11.06 lbf ft).

Inserting the sensor

1. Insert the sensor into the housing cooling.

The small lid of the instrument housing must point to the front after mounting on the fastening bracket (x).

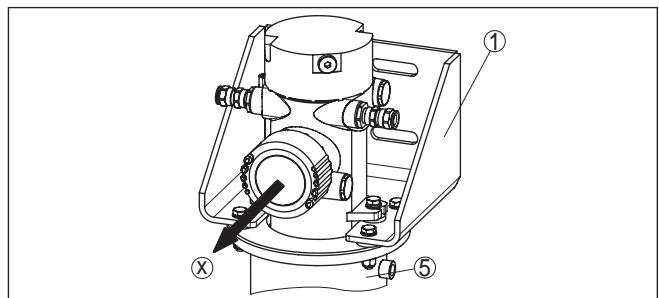

Fig. 3: Mounting direction of the sensor towards the fastening bracket

- 1 Fastening bracket
- 5 Housing cooling
- x Mounting direction of the housing

2. It is advisable to place the sensor and the housing cooling on the floor while inserting. Protect the sensor by covering the sensor housing during mounting.

Mount the sensor with the two screws (7) in the appropriate position.

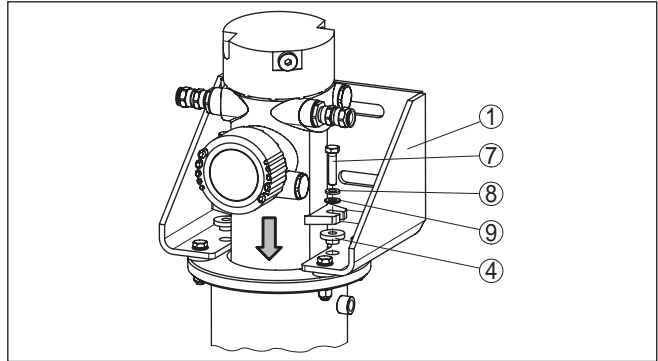

Fig. 4: Mounting the sensor

- 1 Fastening bracket
- 4 Isolating sleeve (2 pieces)
- 7 Hexagon screw M8 x 25 (2 pieces)
- 8 Retaining washer for M8 (2 pieces)
- 9 Washer for M8 (4 pieces)

Housing cooling

Take note of the following general mounting instructions:

- First of all, mount the fastening bracket and the housing cooling, and then the sensor
- The small lid of the instrument housing must point to the front after mounting the fastening bracket (x)
- The sensor together with the water cooling system is very heavy. Use a suitable lifting device for mounting

Mounting the scintillator cooling

Mount the scintillator cooling according to the following assembly drawing:

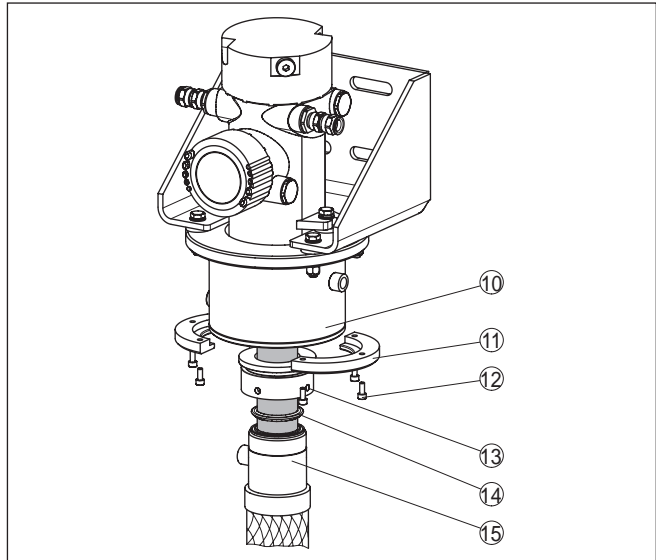

Fig. 5: Mounting scintillator cooling - upper part

- 10 Housing cooling
- 11 Holding flange (bisectional)
- 12 Hexagon socket screw M5 x 12 (6 pieces)
- 13 Compression nut - top
- 14 Seal ring
- 15 Scintillator cooling hose (with connection thread)

1. Slide the upper compression nut (13) from below onto the black scintillator of the sensor. Make sure that the upper compression nut (13) has a fastening slot and that this slot points in the direction of the housing cooling (10).
2. Slide the seal ring (14) from below onto the scintillator hose of the sensor. The seal ring (14) encircles the scintillator hose very tightly and must be moved with a rolling motion over the entire length of the scintillator hose. Make sure that the seal ring is not damaged or contaminated.
3. Push the upper compression nut (13) from below against the housing cooling (10).
4. Place the two half shells of the holding flange (11) from the side onto the upper compression nut (13) and fasten to the housing cooling (10) with the enclosed hexagon socket screws (12).
5. Grease the upper thread of the scintillator cooling hose (15) with acid-free grease. This makes screwing the parts together easier.
6. Push the scintillator cooling hose (15) from below onto the scintillator of the sensor.
7. Slide the seal ring (14) from below into the opening of the upper compression nut (13). Make sure that the seal ring (14) is clean and undamaged and not twisted during the process.

8. Slide the thread of the scintillator cooling hose (15) from below into the upper compression nut (13). Screw the scintillator cooling hose (15) slowly into the upper compression nut (13) up to the stop.
Tighten the upper compression nut (13) with the attached hook wrench up to the stop.
9. The upper part of the scintillator cooling is then sealed. Mount the lower part as follows:

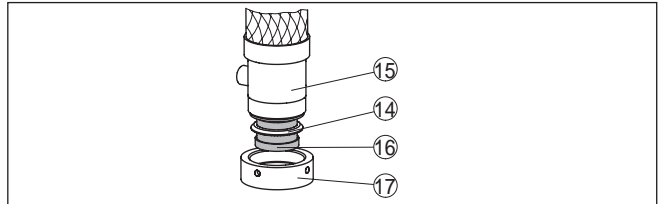

Fig. 6: Mounting scintillator cooling - lower part

- 14 Seal ring
- 15 Scintillator cooling hose (with connection thread)
- 16 Sensor (scintillator hose)
- 17 Compression nut - bottom

10. Grease the lower thread of the scintillator cooling hose (15) with acid-free grease. This makes screwing the parts together easier.
11. Slide a seal ring (14) from below onto the scintillator hose (16) of the sensor. Make sure that the seal ring (14) is not damaged or contaminated.
12. Slide the lower compression nut (17) from below onto the thread of the scintillator cooling hose (15).
13. Screw the lower compression nut (17) slowly onto the scintillator cooling hose (15) up to the stop. Apply counterforce on the fixed tube part of the scintillator cooling hose (15) with a strap wrench (oil filter wrench) and tighten the lower compression nut (17) with the enclosed hook wrench up to the stop.

The scintillator cooling is now completely sealed.

Lifting of the water cooling system



Information:

The sensor together with the water cooling system is very heavy. Use a suitable lifting device for mounting.

Use a sling with sufficient lifting capacity. Take note of the sling marking. You can find the respective weight of the water cooling system in chapter "Technical data".

Place the lifting sling around the cooling tube directly below the flange. The loop is a so-called lark's foot.

Fasten the hoisting sling according to the following illustration.

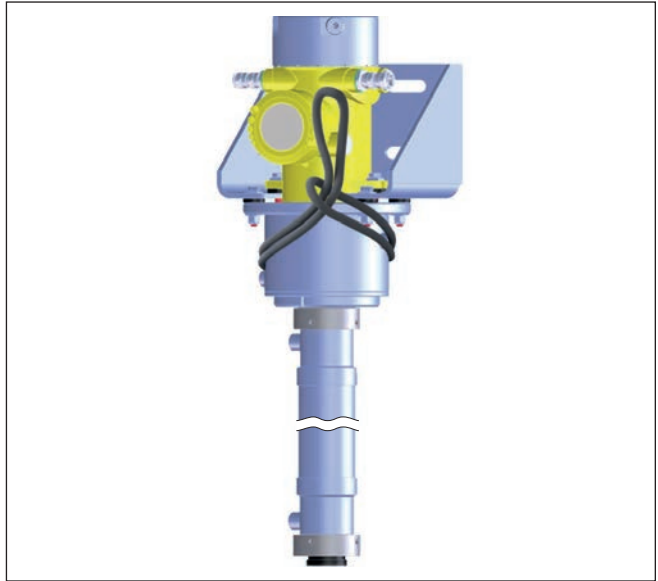

Fig. 7: Attaching the sling

Mounting the sensor

As soon as the water cooling system is mounted, you can install the sensor with the water cooling system in your plant.

You can mount the sensor on your vessel with the enclosed mounting clamps. A number of mounting clamps come with the water cooling system depending on the length of the sensor.

Use a mounting clamp approx. every 450 mm (17.72 in). Adjust the distances between the attached mounting clips.

Take note of the minimum bending radius of the housing cooling, which is 294 mm (11.57 in).

1. Determine the exact mounting position of one or several mounting clamps and mark the holes.

You can find the drilling template in the technical data.

Align the mounting positions exactly and average the distances between the enclosed mounting clamps.

Drill appropriate holes (max. M12) for fastening the mounting clamps.



Note:

The mounting clamps do not come with fastening screws. Use fastening elements that are appropriate for the situation in your plant.

2. Position the base plate (35) and fasten it in the specified mounting position.
3. Fasten additional mounting clamps exactly aligned in the same way.

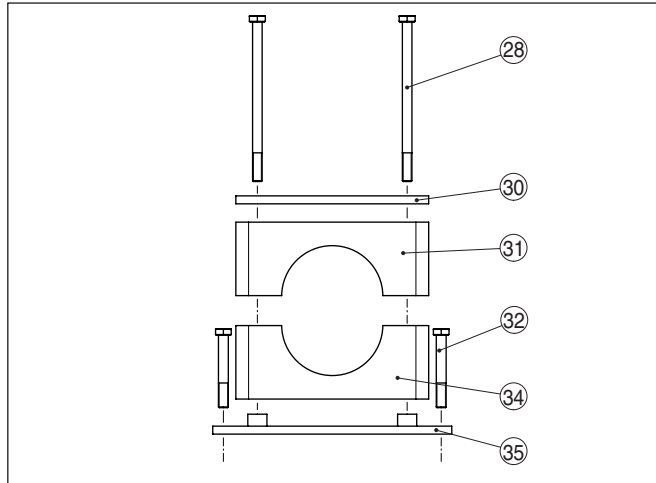

Fig. 8: Mounting clamps

- 28 Hexagon screw M12 x 190
- 30 Cover plate - metal
- 31 Upper clamping jaw
- 32 Fastening screw (provided by the customer)
- 34 Lower clamping jaw
- 35 Bottom plate - metal (with slot holes)

4. Place the lower clamping jaw (34) onto the bottom plate (35).
5. Insert the sensor with the cooling system into the lower clamping jaw (34) and align the cooling system.
6. Place the cover plate (30) onto the upper clamping jaw (31) and place the two parts onto the lower clamping jaw (34).
7. Insert the two hexagon screws (28) into the holes of the cover plate (30) and the upper clamping jaw (31) and then push the hexagon screws (28) through the two clamping jaws.
8. Tighten the two hexagon screws (28) with a torque of 8 Nm (5.9 lbf ft).

You can find further information on sensor mounting in the operating instructions manual of the sensor.

Electrical connection

The housing cooling lid is screwed onto the existing sensor housing like a housing lid.

1. Unscrew the housing lid (18) from the sensor.
2. Connect the sensor to power supply. Keep the instructions of the operating instructions manual of the appropriate sensor in mind.

There is a connection diagram in the housing lid (18). This diagram is not in the housing cooling lid (19). So please note the details of the electrical connection in the operating instructions manual of the sensor.

**Note:**

The cooling system is used in areas with high temperatures. Therefore, use temperature-resistant cable and install it in such a way that contact with hot components is avoided.

Mounting of the housing cooling lid

1. Clean the thread of the housing cooling lid (19) and the thread on the housing.
2. Screw the housing cooling lid (19) onto the sensor instead of the housing lid (18) and turn the housing cooling lid (19) up to the stop.

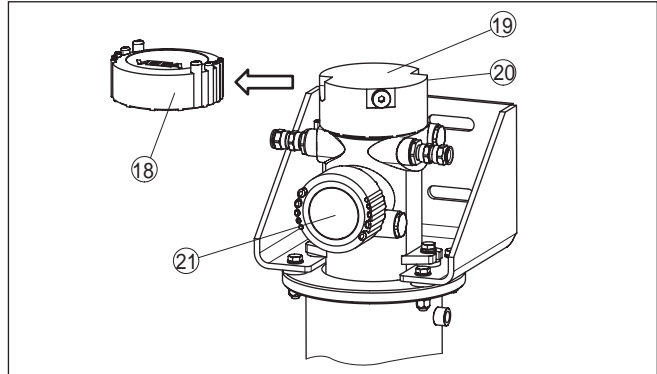

Fig. 9: Mounting of the housing cooling lid

18 Housing lid

19 Housing cooling lid

20 Connection opening for the coolant hose

21 Sensor

Connect cooling

The housing cooling and the housing cooling lid must be connected to the cooling circuit.

All threads for the cooling connection on the sensor are inner threads.

The required coolant hoses are part of the scope of delivery.

Use clean tap water or distilled water for cooling. Oil or salt water are not suitable for the cooling system.

Make sure that the coolant cables do not freeze, e.g. in case of a shutdown.

You can find information on the throughput and the temperature of the cooling water in the technical data section.

Coolant pump

The water cooling may only be operated in an unpressurized state.

Use an open cooling circuit that circulates the coolant through the system by means of a pump.

Plan the coolant pump and a possible re-cooling system according to the required inlet temperature, pumping height and water throughput.

If you want to integrate a gate valve into the system, then install it only in the feed line to avoid pressurization in the cooling system.

**Caution:**

Make sure that the cooling water supply is reliable und interruption-free. Plan the necessary steps for a possible pump failure, missing coolant, etc.

We recommend installing a temperature sensor (in the return flow) that triggers an alarm when a critical temperature is reached.



If you want to use the water cooling in an application that is SIL qualified, you have to assess the SIL failure rates of the complete water cooling system and the cooling water supply yourself.

1. Install the coolant hoses in such a way that they do not get kinked or come into contact with hot components.

**Information:**

Note the flow direction of the coolant. The direction of flow should be from bottom to top so that no voids can arise.

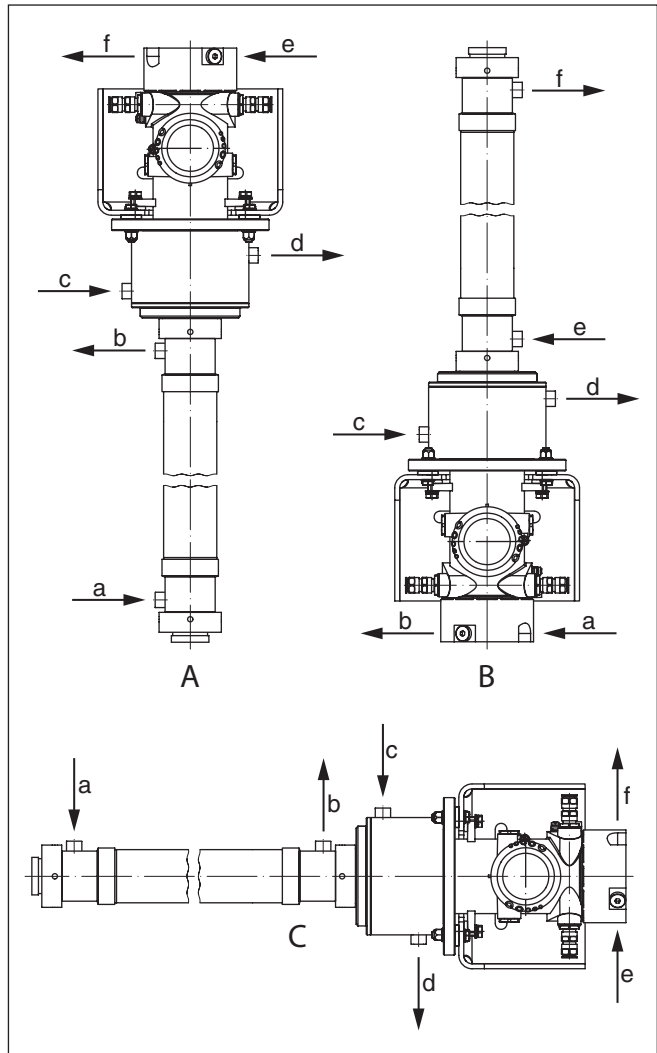

Fig. 10: Mounting position of the cooling system - note flow direction of the coolant (a, b, c...)

- A Vertical mounting - housing head on top
- B Vertical mounting - housing head on bottom
- C Horizontal mounting

2. Connect the lines for the cooling water.

All threads for the cooling connection on the sensor are inner threads.

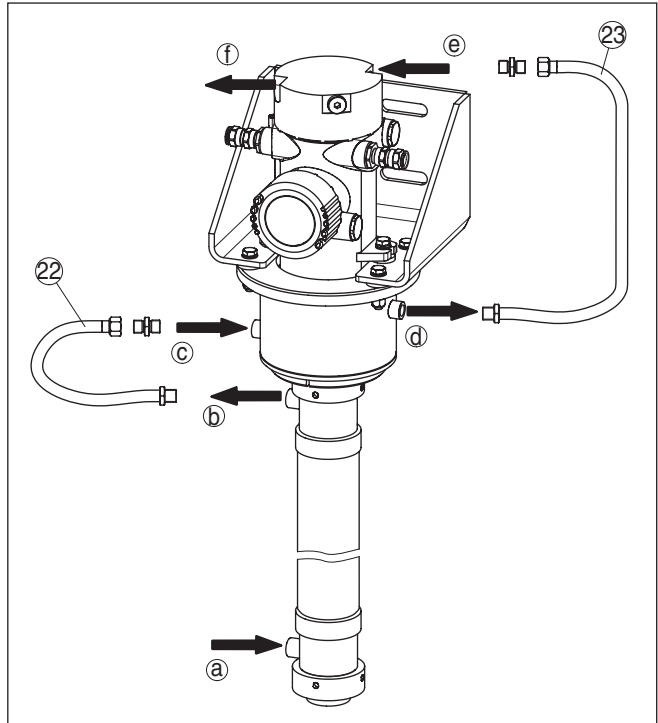

Fig. 11: Flow direction of the coolant (vertical mounting, housing head on top)

- a Coolant inlet - scintillator cooling
- b Coolant outlet - scintillator cooling
- c Coolant inlet - housing cooling
- d Coolant outlet - housing cooling
- e Coolant inlet - housing cooling lid
- f Coolant outlet - housing cooling lid
- 22 Coolant hose - scintillator cooling/housing cooling
- 23 Coolant hose - housing cooling/housing cooling lid



Note:

The enclosed coolant hoses are pre-fabricated in their length. One end of the hose has a fixed connection thread, the other has a rotatable connection.

This ensures that the coolant hoses remain straight.

All connection threads have seals already in place. Make sure that the seals are there when mounting.

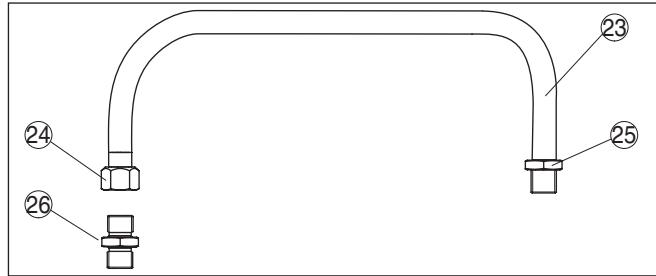

Fig. 12: Pre-assembled coolant hose

23 Coolant hose

24 Rotatable connection thread

25 Fixed connection thread

26 Double nipple ¼" (DIN ISO 228)

3. First screw in the fixed connection thread (25) of the coolant hose and tighten the fitting with a torque of 25 Nm (18.43 lbf ft).
4. Unscrew the double nipple (26) from the rotatable connection thread (24) of the coolant hose and mount it in the connection hole of the sensor cooling.

Tighten the double nipple (26) with a torque of 25 Nm (18.43 lbf ft).

5. Screw the rotatable thread (24) into the double nipple (26). Apply counterforce on the rear nut with a fork wrench (SW 19) and tighten the connection thread with a second fork wrench with a torque of 25 Nm (18.43 lbf ft).
6. Fill the water cooling system.

Check the tightness of the system and the hose fittings.

The cooling system may only be operated in an unpressurized state.



Caution:

Do not loosen any screws or hose connections during operation and make sure that the coolant supply is reliable and interruption-free.

Install a protective grid

Take note of the operating instructions manuals of the corresponding radiation-based sensors and the source holder.

When handling radioactive substances, unnecessary radiation exposure must be avoided.

If there are gaps or intervening spaces after mounting, provide protective fences or grids to keep hands away from the dangerous area. Such areas must be marked accordingly.

Install a safety barrier on both sides of the cooling system. A sheet metal cover or an appropriately shaped plastic sheet can also be used.

3 Replacement parts

3.1 Available spare parts - water cooling

Selected components of the cooling are available as replacement parts. The following parts are available:

The stated quantity is the quantity delivered.

Water cooling

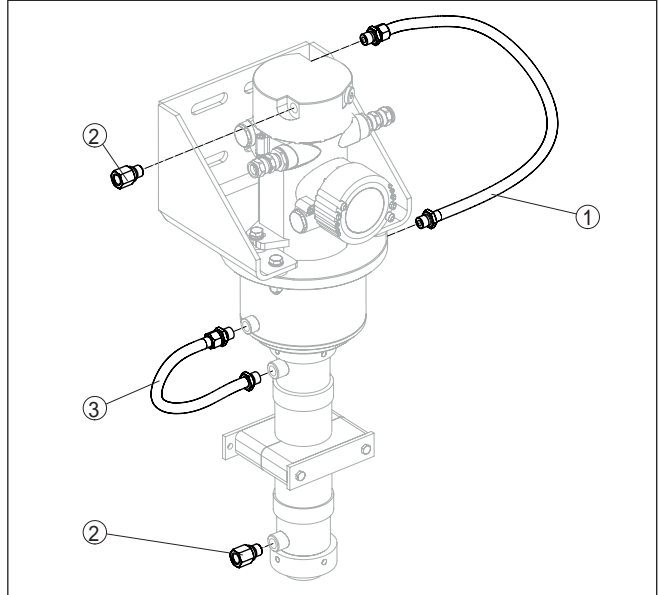

Fig. 13: Scintillator cooling - hoses and adapters

- 1 Coolant hose - housing cooling/housing cooling lid
- 2 Threaded adapter - water cooling ¼ NPT (1 pce.)
- 3 Coolant hose - scintillator cooling/housing cooling

**Scintillator cooling hose
- top**

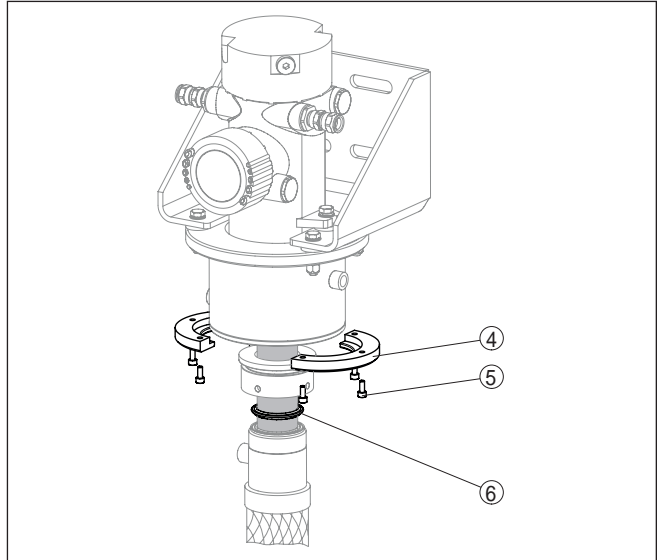

Fig. 14: Mounting kit - scintillator cooling hose - top

- 4 Holding flange (bisectional)
- 5 Hexagon socket screw M5 x 12 (6 pieces)
- 6 Seal ring (included in the mounting kit "Scintillator cooling hose, bottom")

**Scintillator cooling hose
- bottom**

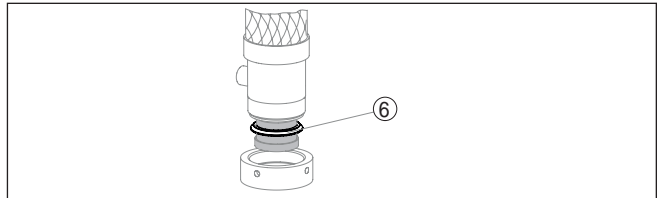

Fig. 15: Mounting kit - scintillator cooling hose - bottom

- 6 Sealing ring (2 pieces)

4 Supplement

4.1 Technical data

General data

Take note of the information in the operating instructions manual of the installed FIBERTRAC level sensor and the source holder

Material 316L corresponds to 1.4404 or 1.4435

Materials

- Housing cooling 316L
- Housing cooling lid 316L
- Metallic braided hose of the housing cooling Stainless steel
- Seal NBR

Application temperature See following tables (throughput - coolant)

Sensor length (L) 7 m (23 ft)

Weight

- Housing cooling 2.3 kg (5.1 lbs)
- Scintillator cooling 8.8 kg/m (1.62 oz/in)
- Housing cooling lid 2.4 kg (5.3 lbs)
- Fastening bracket 4.3 kg (9.5 lbs)
- Fastening clamp 0.5 kg (1.1 lbs)

Total length of the water cooling system 7 m (275.6 in)

Torques

- Screws - Sensor mounting (M8) 15 Nm (11.06 lbf ft)
- Nuts - housing cooling (M8) 15 Nm (11.06 lbf ft)
- Hexagon socket screws - holding flange (M6) 4.5 Nm (3.3 lbf ft)
- Coolant hoses, threaded fittings 25 Nm (18.43 lbf ft)
- Screws for mounting clamps 8 Nm (5.9 lbf ft)

Connection thread of coolant hoses ¼" DIN ISO 228 outer thread
(adapters for NPT fittings are enclosed with respective version)

Throughput - coolant water

Cooling water pressure The cooling system may only be operated in an unpresurized state.

Sensor length < 2 m (< 6.56 ft)

Coolant temperature	Ambient temperature		
	+70 °C (+158 °F)	+80 °C (+176 °F)	+100 °C (+212 °F)
< +20 °C (+68 °F)	0.5 l/min (0.14 US gal/min)	0.5 l/min (0.14 US gal/min)	2 l/min (0.53 US gal/min)
< +30 °C (+86 °F)	0.5 l/min (0.14 US gal/min)	0.5 l/min (0.14 US gal/min)	5 l/min (1.32 US gal/min)

48524-EN-180130

Tab. 1: Required water throughput to reach the max. permissible sensor temperature of +60 °C (+140 °F)

Sensor length > 2 m (> 6.56 ft)

Coolant temperature	Ambient temperature		
	+70 °C (+158 °F)	+80 °C (+176 °F)	+100 °C (+212 °F)
< +20 °C (+68 °F)	0.5 l/min (0.14 US gal/min)	2 l/min (0.53 US gal/min)	5 l/min (1.32 US gal/min)
< +30 °C (+86 °F)	0.5 l/min (0.14 US gal/min)	2 l/min (0.53 US gal/min)	7 l/min (1.85 US gal/min)

Tab. 2: Required water throughput to reach the max. permissible sensor temperature of +60 °C (+140 °F)

4.2 Dimensions

Active water cooling system

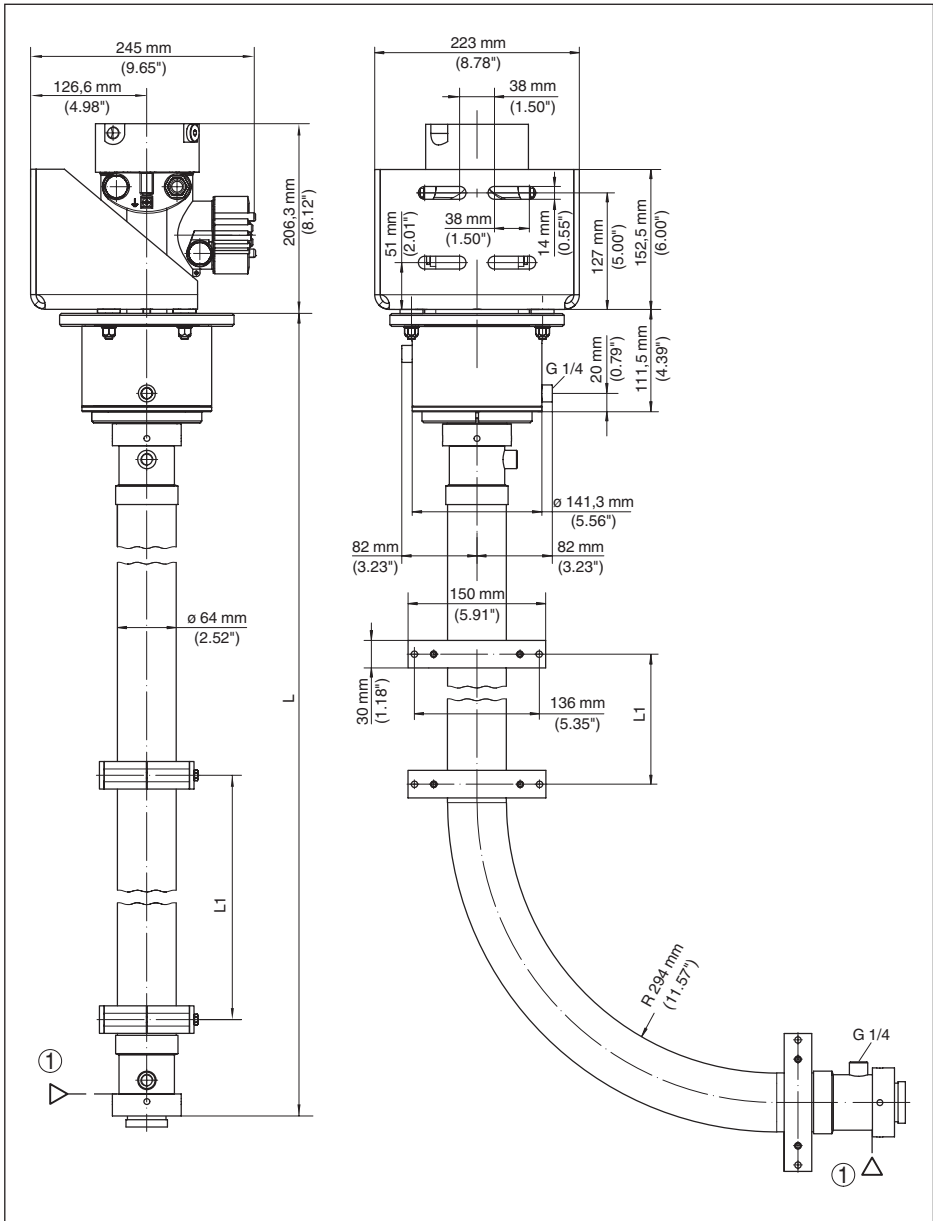

Fig. 16: Active water cooling system with housing cooling and housing cooling lid

- 1* Position of the lower measuring range end (on the upper edge of the lower compression nut)
- L* Total length of the water cooling system
- L1* Distance between the mounting clips = approx. 450 mm (17.72 in)

A large grid of graph paper for taking notes, consisting of 20 columns and 30 rows of small squares.

Printing date:

VEGA

All statements concerning scope of delivery, application, practical use and operating conditions of the sensors and processing systems correspond to the information available at the time of printing.

Subject to change without prior notice

© VEGA Grieshaber KG, Schiltach/Germany 2018



48524-EN-180130

VEGA Grieshaber KG
Am Hohenstein 113
77761 Schiltach
Germany

Phone +49 7836 50-0
Fax +49 7836 50-201
E-mail: info.de@vega.com
www.vega.com