

Supplementary instructions

Mounting bracket KV 31

For tubes with \varnothing 400 ... 600 mm

Horizontal sensor mounting



Document ID: 49230



VEGA

Contents

1 Product description	
1.2 High temperatures.....	4
2 Mounting	
2.2 Heat protection kit.....	6
3 Supplement	
3.1 Technical data.....	9
3.2 Dimensions.....	10
3.3 Industrial property rights.....	13
3.4 Trademark.....	13

1 Product description

The KV 31 is a mounting bracket for radiation-based measuring systems. It is suitable for pipes irradiated at right angles.

For horizontal sensor mounting

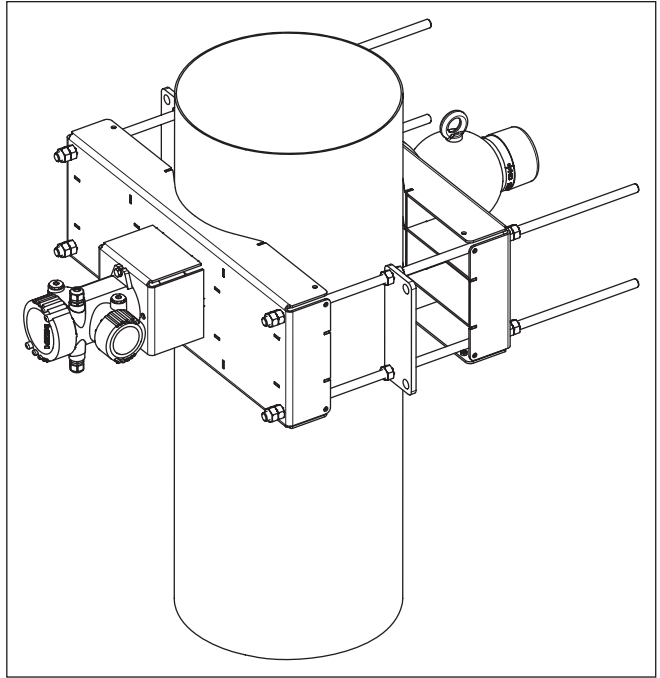

Fig. 1: Mounting bracket with horizontally mounted sensor

Scope of delivery

The following parts belong to the scope of delivery of KV 31.

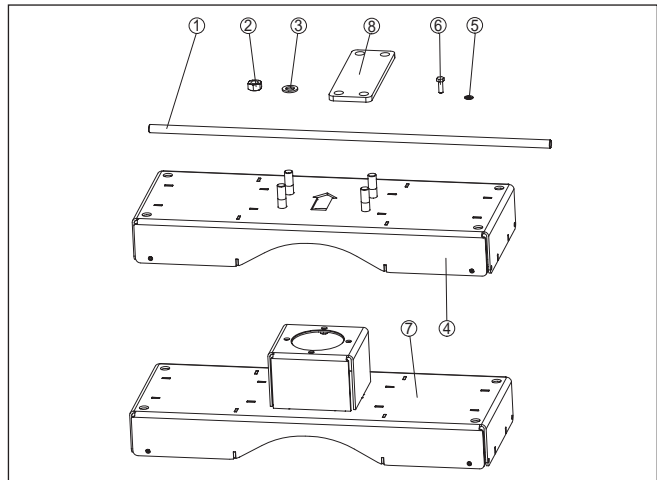

Fig. 2: Mounting bracket KV 31 for pipes irradiated at right angles - horizontal sensor mounting

- 1 Threaded rods M16 x 800 mm (M16 x 31.5 in), (4 pieces)
- 2 Hexagon nuts M16 (28 pieces)
- 3 Washers for M16 (4 pieces)
- 4 Clamp - Source holder side (1 Stück)
- 5 Washers for M8 (2 pieces)
- 6 Hexagon screws M8 x 25 (2 pieces)
- 7 Clamp - Sensor side (MINITRAC), (1 piece)
- 8 Fixing plates (2 pieces)

1.2 High temperatures

To protect the sensor against high temperatures, the mounting bracket can be equipped optionally with a heat protection kit.

The surface temperature of the tube can be up to max. +100 °C (212 °F) with heat protection kit with insulating boards.

Check the local conditions (surface temperature).

Contact our specialists, if you are not sure.

2 Mounting

Operating instructions

Take note of the operating instructions of the corresponding sensor MINITRAC and the source holder.

Mounting brackets for horizontal mounting

Take note of the following mounting instructions:

- Mount the bracket first, then the sensor and the source holder
- The arrow cutouts in the clamp (source container side) and in the transport lug of the source holder must point in the same direction (A) after mounting
- Make sure that the two clamps (4 and 7) of the bracket are in parallel. Do this by measuring the lateral distances between the clamps
- To avoid injuries, shorten the threaded rods (1) of the brackets to a suitable length after mounting

Horizontal sensor mounting

Mount the bracket according to the following assembly drawing:

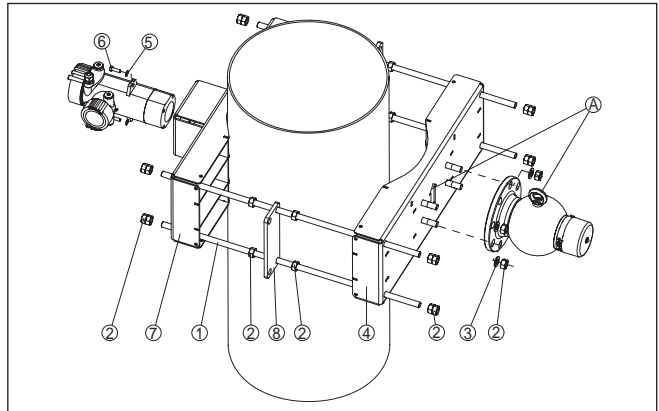

Fig. 3: Mounting bracket KV 31 with horizontally mounted sensor

- 1 Threaded rods M16 x 800 mm (M16 x 31.5 in), (4 pieces)
- 2 Hexagon nuts M16 (28 pieces)
- 3 Washers for M16 (4 pieces)
- 4 Clamp - Source holder side (1 Stück)
- 5 Washers for M8 (2 pieces)
- 6 Hexagon screws M8 x 25 (2 pieces)
- 7 Clamp - Sensor side (MINITRAC), (2 pieces)
- 8 Fixing plates (2 pieces)
- A Arrow cutouts of the clamp and eyebolt point in the same direction

1. Make sure that the two clamps (4 and 7) of the bracket are in parallel. Do this by measuring the lateral distances between the clamps.
2. Tighten the nuts (2) of the threaded rod (1) evenly. Keep the tube diameter and the stability of the tube material in mind. Avoid deformation of the tube through an overtightening of the mounting bracket.

If you have the impression that the tube cannot permanently carry the weight of the mounting bracket, sensor and source container, mount a suitable support below the mounting bracket.

3. Shorten the threaded rods after mounting to avoid injuries.

Install a protective grid

If there are gaps or intervening spaces around the installation, provide protective fences or grids to keep hands away from the dangerous area. Such areas must be marked accordingly.

Install a protective grid on both sides of the mounting bracket. A sheet metal cover or a correspondingly shaped plastic sheet can also be used.

Corresponding holes for screws of size M5 are provided on the mounting bracket.

Mount the protective grid according to the following assembly drawing:

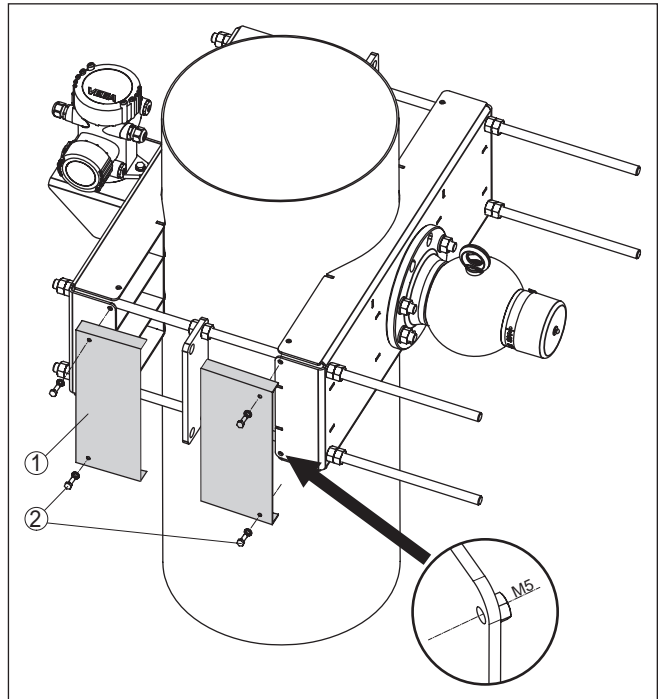

Fig. 4: Install the protective grid on both sides of the mounting bracket

- 1 Protective grid or shrouds (provided by customer)
- 2 Screws M5 (4 pieces), (provided by customer)

2.2 Heat protection kit

Optional heat protection kit

Tubes or vessels with hot products lead to high temperatures on the sensor due to heat radiation.

A heat protection kit with several insulating boards can be used on the mounting bracket as an option to protection against radiation heat.

The heat protection kit protects the sensor reliably against heat up to a surface temperature of the tube of 100 °C (212 °F).

For the sensor side a special bracket must be used for this purpose. Hence the heat protection kit must be also taken into account while ordering. A retrofitting is not possible.

→ Mount the heat protection kit according to the following illustrations:

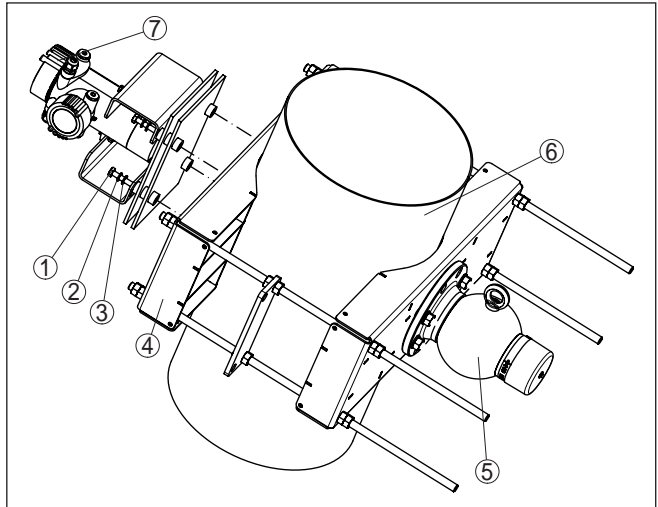

Fig. 5: Mounting bracket with heat protection kit

- 1 Screw M10 x 90 (4 pcs.)
- 2 Spring ring M10 (4 pieces)
- 3 Washer M10 (4 pieces)
- 4 Bracket - sensor side (MINITRAC)
- 5 Source holder
- 6 Tube
- 7 Level sensor MINITRAC

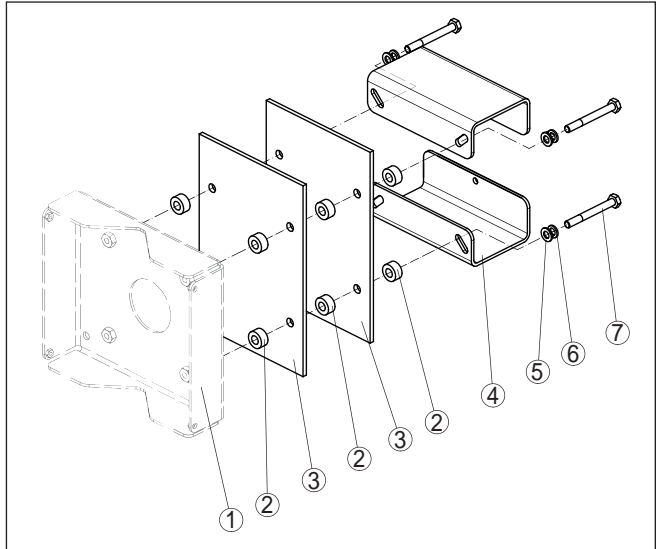

Fig. 6: Mounting of the heat protection plates

- 1 Bracket - sensor side (MINITRAC)
- 2 Plastic washer M10 (12 pcs.)
- 3 Plastic washer 305 x 305 (2 pcs.)
- 4 Clamp - U-shape (2 pcs.)
- 5 Washer M10 (4 pieces)
- 6 Spring ring M10 (4 pieces)
- 7 Screw M10 x 90 (4 pcs.)

3 Supplement

3.1 Technical data

General data

Take note of the information in the operating instructions manual of the installed MINITRAC level sensor and the source holder

Material 316L corresponds to 1.4404 or 1.4435

Materials

- Mounting bracket 316L
- Threaded rods 316L

Weight (without sensor and source holder) 39 kg (86 lbs)

Torques

- Screws - Sensor mounting (M8) 15 Nm (11.06 lbf ft)
- Nuts - VEGASOURCE (M16) 20 Nm (14.75 lbf ft)
- Threaded rods (M16) Dependent on the tube material

3.2 Dimensions

KV 31 - for horizontal sensor mounting

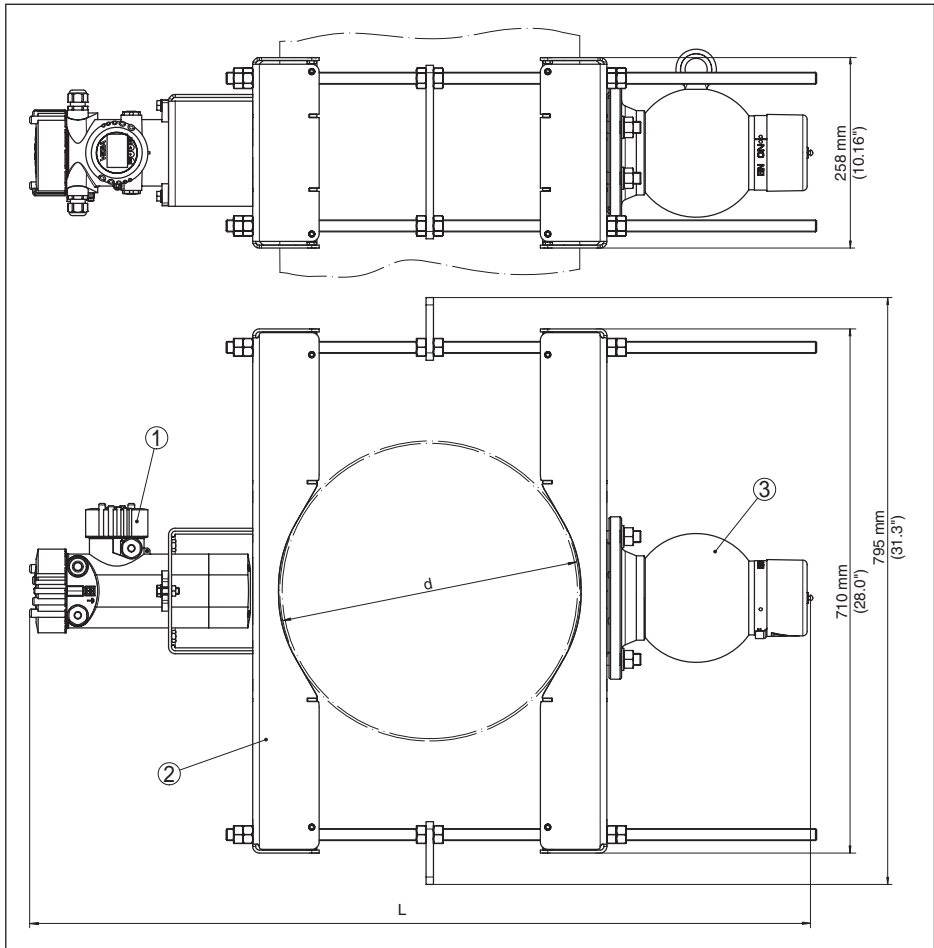

Fig. 7: Mounting bracket with horizontally mounted sensor

- 1 Level sensor MINITRAC
- 2 Mounting bracket - KV 31
- 3 Source holder VEGASOURCE

L = total length of the measuring system (see following table)

d = tube diameter (see following table)

Tube DN (in)	Tube diameter (d)	Total length (L)
DN 400 mm (16 in)	ø 406.4 mm (16 in)	896 mm (35.3 in)
DN 450 mm (18 in)	ø 457.2 mm (18 in)	967 mm (38.1 in)
DN 500 mm (20 in)	ø 508 mm (20 in)	1033 mm (40.7 in)

Tube DN (in)	Tube diameter (d)	Total length (L)
DN 550 mm (22 in)	ø 559 mm (22 in)	1075 mm (42.3 in)
DN 600 mm (24 in)	ø 610 mm (24 in)	1141 mm (44.9 in)

KV 31, horizontal sensor mounting - with heat protection kit

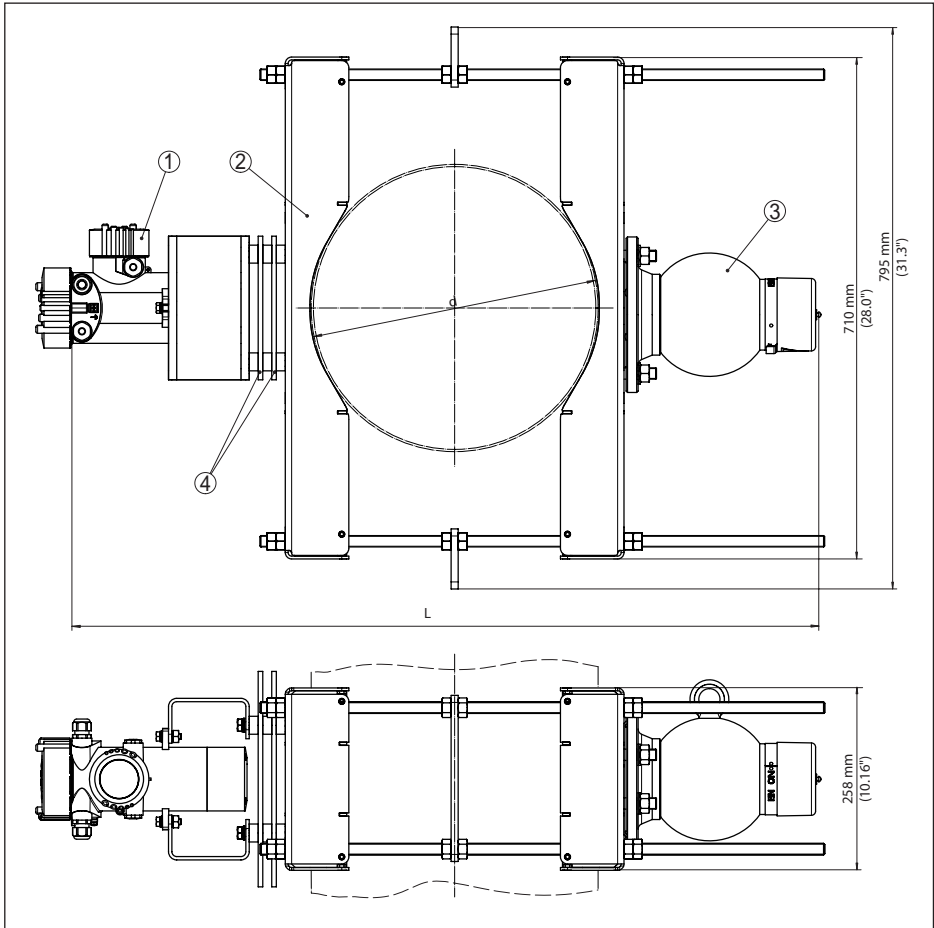

Fig. 8: Mounting bracket with horizontally mounted sensor and heat protection kit

- 1 Level sensor MINITRAC
 - 2 Mounting bracket - KV 31
 - 3 Source holder
 - 4 Heat protection kit
- L = total length of the measuring system (see following table)
d = tube diameter (see following table)

49230-EN-170724

Tube DN (in)	Tube diameter (d)	Total length (L)
DN 400 mm (16 in)	ø 406.4 mm (16 in)	1112 mm (43.8 in)
DN 450 mm (18 in)	ø 457.2 mm (18 in)	1171 mm (46.1 in)
DN 500 mm (20 in)	ø 508 mm (20 in)	1229 mm (48.4 in)
DN 550 mm (22 in)	ø 559 mm (22 in)	1288 mm (50.7 in)
DN 600 mm (24 in)	ø 610 mm (24 in)	1346 mm (53.0 in)

3.3 Industrial property rights

VEGA product lines are global protected by industrial property rights. Further information see www.vega.com.

VEGA Produktfamilien sind weltweit geschützt durch gewerbliche Schutzrechte.

Nähere Informationen unter www.vega.com.

Les lignes de produits VEGA sont globalement protégées par des droits de propriété intellectuelle. Pour plus d'informations, on pourra se référer au site www.vega.com.

VEGA líneas de productos están protegidas por los derechos en el campo de la propiedad industrial. Para mayor información revise la pagina web www.vega.com.

Линии продукции фирмы ВЕГА защищаются по всему миру правами на интеллектуальную собственность. Дальнейшую информацию смотрите на сайте www.vega.com.

VEGA系列产品在全球享有知识产权保护。

进一步信息请参见网站www.vega.com。

3.4 Trademark

All the brands as well as trade and company names used are property of their lawful proprietor/originator.





Printing date:

VEGA

All statements concerning scope of delivery, application, practical use and operating conditions of the sensors and processing systems correspond to the information available at the time of printing.

Subject to change without prior notice

© VEGA Grieshaber KG, Schiltach/Germany 2017



49230-EN-170724

VEGA Grieshaber KG
Am Hohenstein 113
77761 Schiltach
Germany

Phone +49 7836 50-0
Fax +49 7836 50-201
E-mail: info.de@vega.com
www.vega.com