

Diese Zeichnung bleibt Eigentum der Firma VEGA-Grieshaber KG
 Sie darf ohne unsere Genehmigung weder kopiert,
 noch 3. Personen oder Konkurrenzfirmen mitgeteilt werden.
 (§ 2 Abs.1 Ziff.7 UrHG vom 05.05.1965)

This drawing remains property of VEGA-Grieshaber KG
 It may be neither copied nor informed to third persons
 or competitors without our approval.
 (§ 2 paragraph 1 fig.7 copyright act of 9th Sept. 1965)

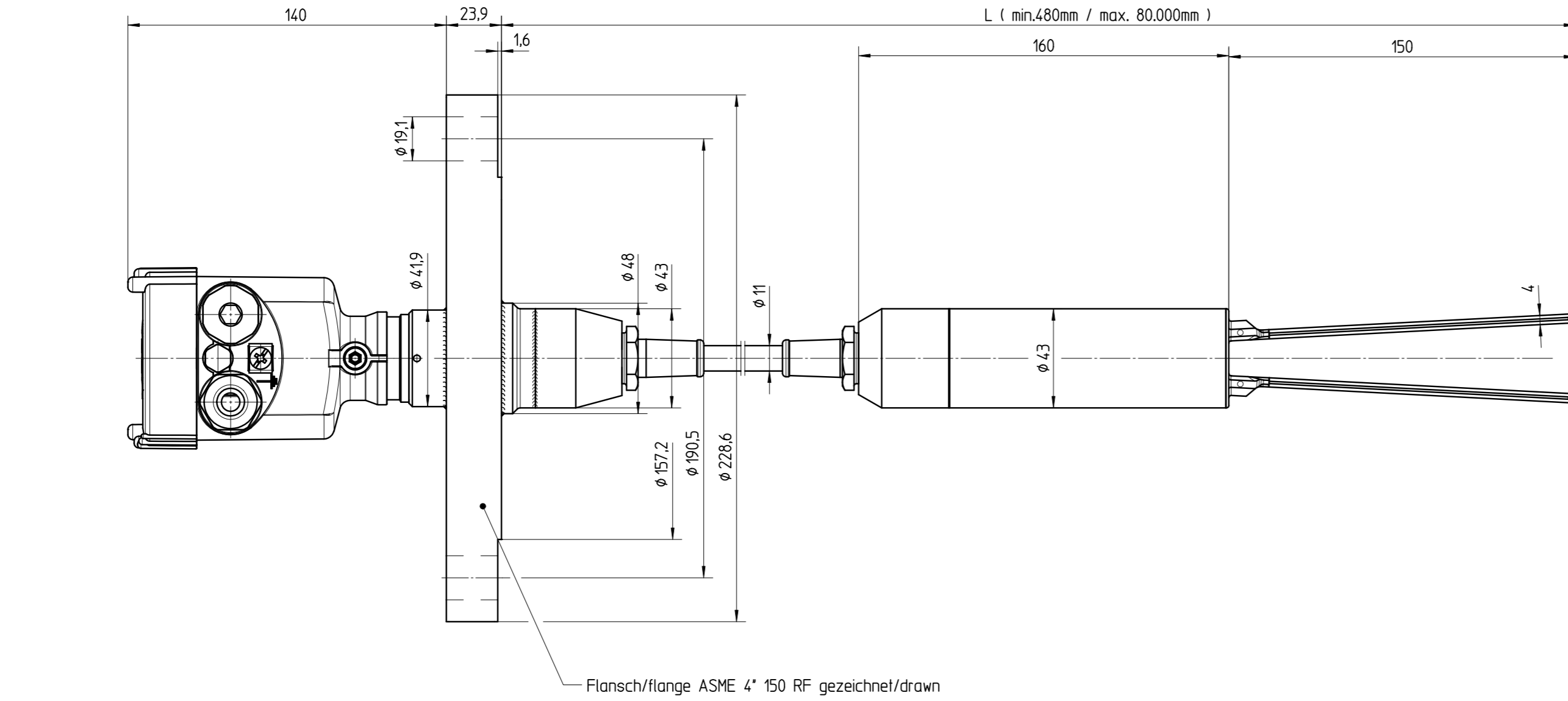

WAVE62
Flanschversion / flange version

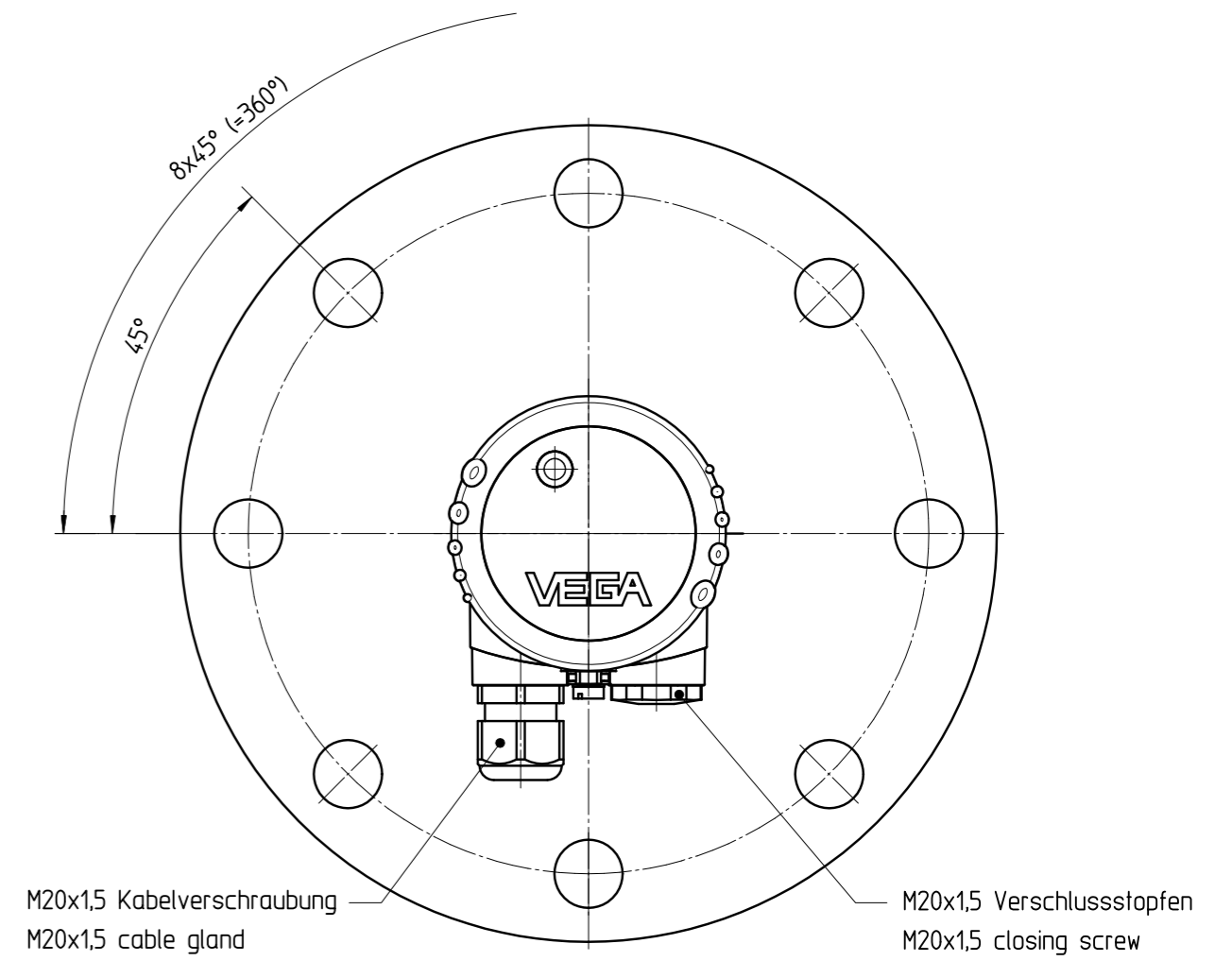
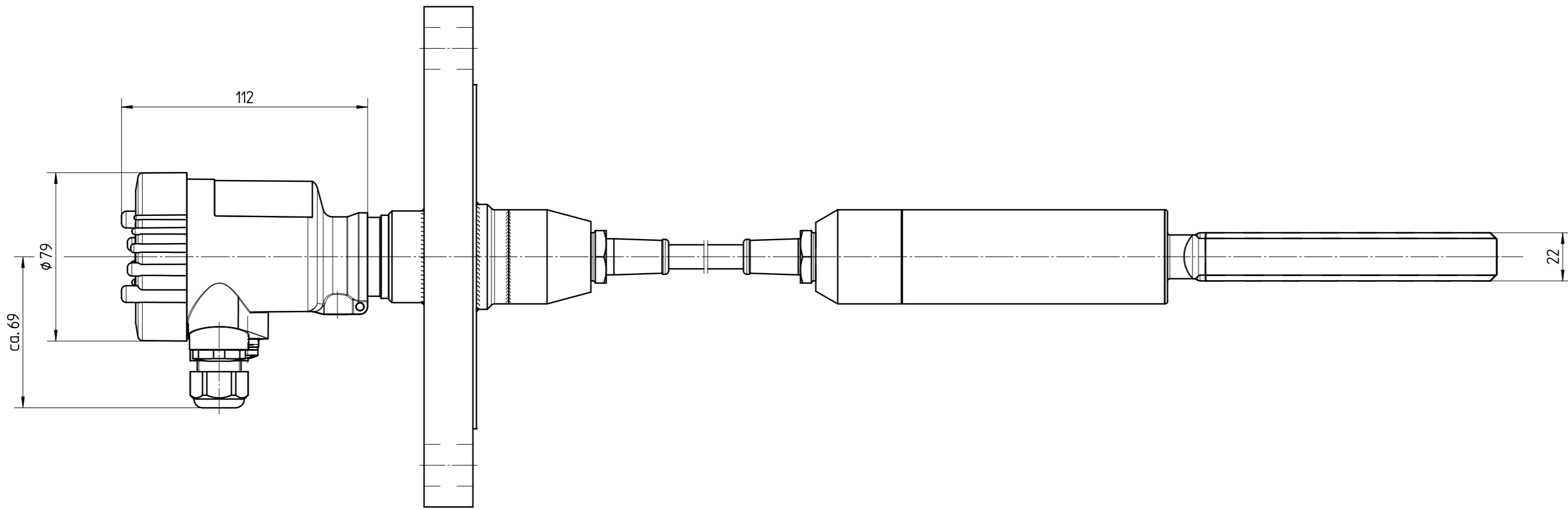

01		Gehäuse neu (And.-Nr. 9458) Housing new (ch.-no. 9458)		26.02.2010		lizenberger ohmberg	
Passmaß/tol.dimens.		Abmaß/allowance		Änderung / changing		Datum / Date	
Freimaß/tolerance ISO 2768-mK		gezeichnet drawn freigegeben checked		Datum/Date 24.08.2006 25.08.2006		Name/Name ohmberg Oberfall	
Werkstoff / Material		Maßstab Scale 1:2		Originalformat size of origin A2		Benennung WAVE62 Flansch 4" 150lb RF Sensorgehäuse Ku Masszeichnung Art.Nr. / Art.No. MB2844 Zchns.-Nr. / Drawing No. MB2844 Var.Fam.: Teil ähnl. / sim. part MB2216 Arb.Anw. / work.instr.	
				Description VB66 flange 4" 150lb RF dimensioned drawing		And.-Zust. / Vers. 01	
				Var.Fam.2: Ersatz f. / replacement f.			