

Diese Zeichnung bleibt Eigentum der Firma VEGA-Grieshaber KG. Sie darf ohne unsere Genehmigung weder kopiert, noch 3. Personen oder Konkurrenzfirmen mitgeteilt werden. (§ 2 Abs.1 Ziff.7 UrHG vom 09.09.1965)

This drawing remains property of VEGA-Grieshaber KG. It may be neither copied nor informed to third persons or competitors without our approval. (§ 2 paragraph 1 fig.7 copyright act of 9th Sept. 1965)

X 5:1

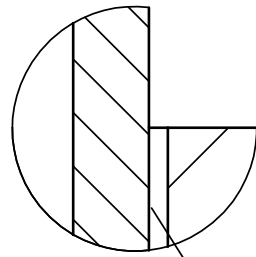

ca. 0,2 mm Spalt  
approx. 0.2 mm gap

Y 5:1

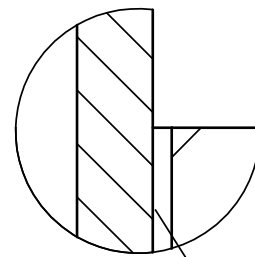

ca. 0,2 mm Spalt  
approx. 0.2 mm gap

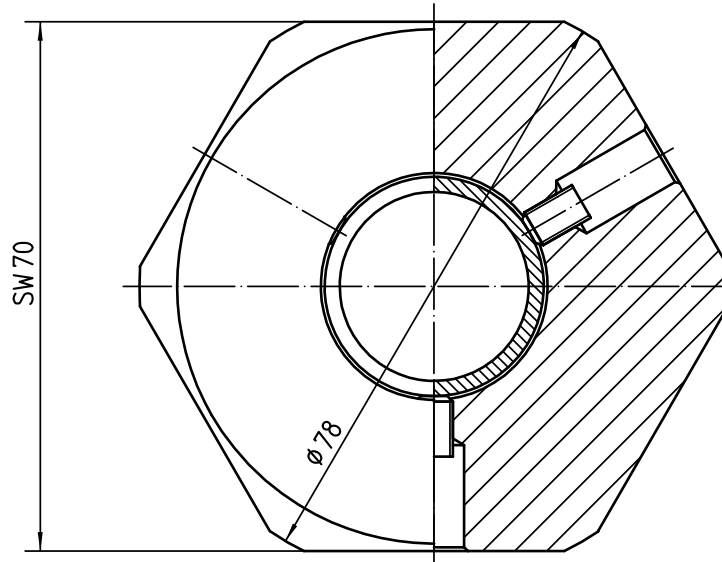
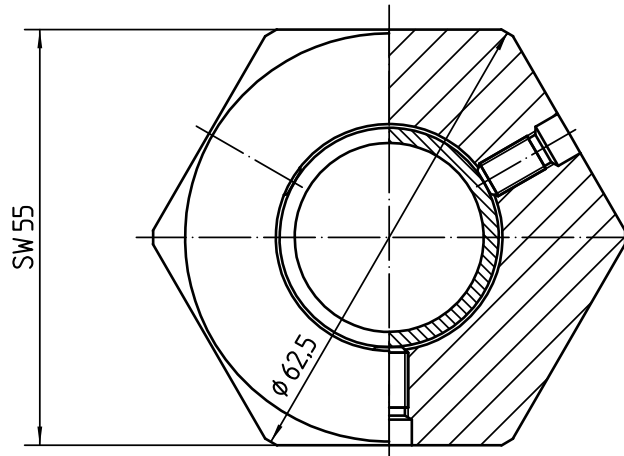
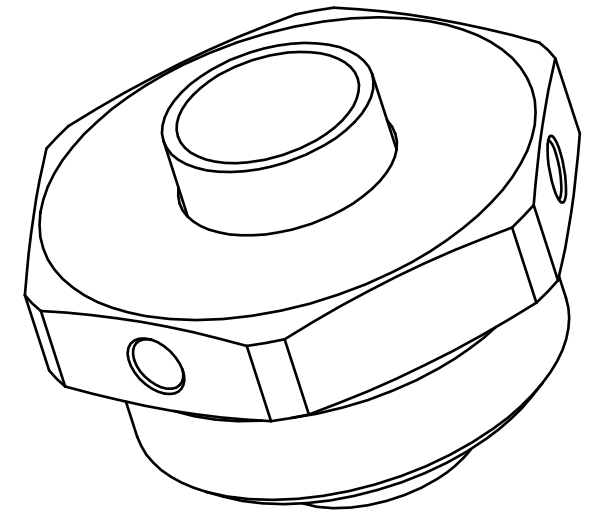
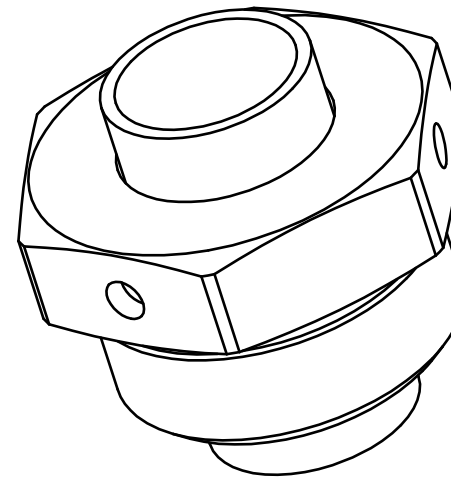
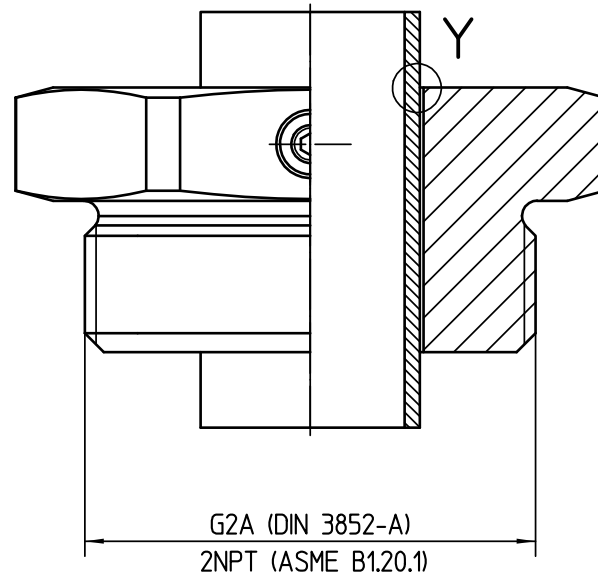
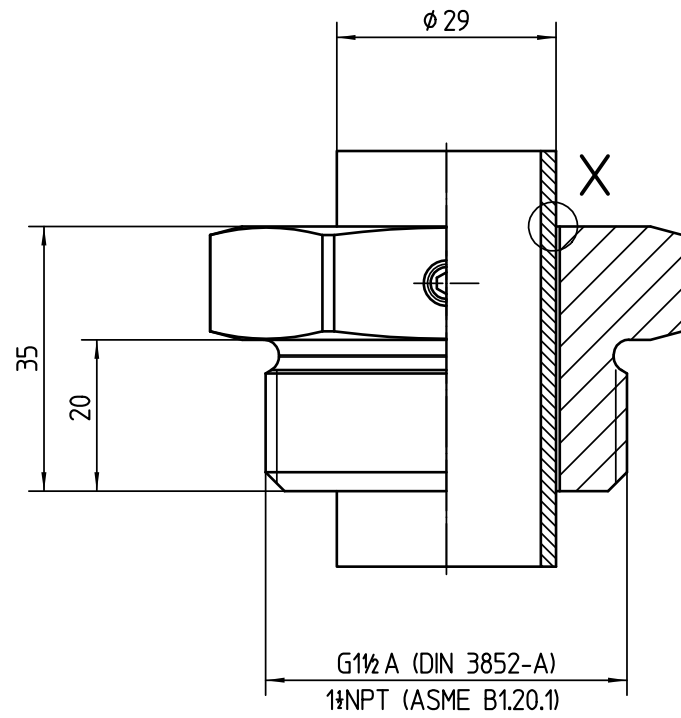

Achtung! Nur für drucklosen Betrieb.  
Note! Only for pressureless handling.

Mindestsensorklänge 205mm  
minimum sensor length 205mm

Passmaß/tol.dimens.		Abmaß/allowance		Änderung / revision			Änd. Nr. ECN no.	Datum / Date	gezeichnet / freigegeben drawn / checked
Freimaßtoleranz general tolerance		gezeichnet drawn	Datum/Date	Name/Name	Benennung	Description			
freigegeben checked		10.11.2004	moreiras	Arretierschraubung Ø29	lock fitting Ø29				
Maßstab Scale		10.11.2004	arnoldt	0 bar / -50°C - 250°C	0 bar / -50°C - 250°C				
Originalformat size of origin		VEGA			Art.Nr. / Art.No.		MB2368		
Blatt / Sheet von / of		VEGA Grieshaber KG Postfach 1142 77757 Schiltach Germany			Zchngs.-Nr. / Drawing No.		MB2368		
1		Var.Fam.: ARV-VIB63.1			Var.Fam.2:		02		
1		Teil ähnl. / sim. part			Ersatz f./replacement f.				
1		Arb.Anw. / work.instr.			Alle Maße in mm!				